

Clamping devices

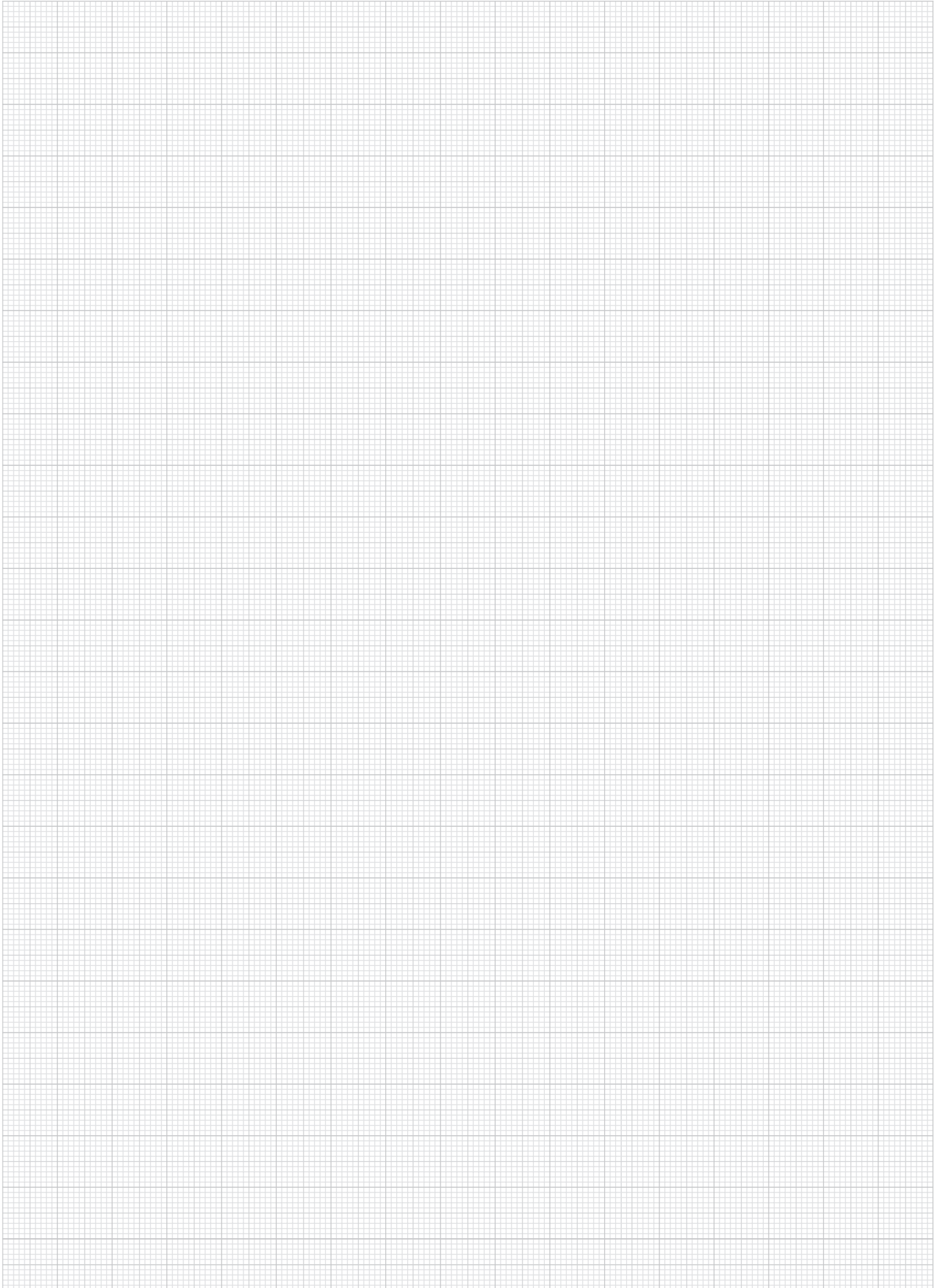



Mounting instructions for eccentric clamp module



Insert by pushing and turning

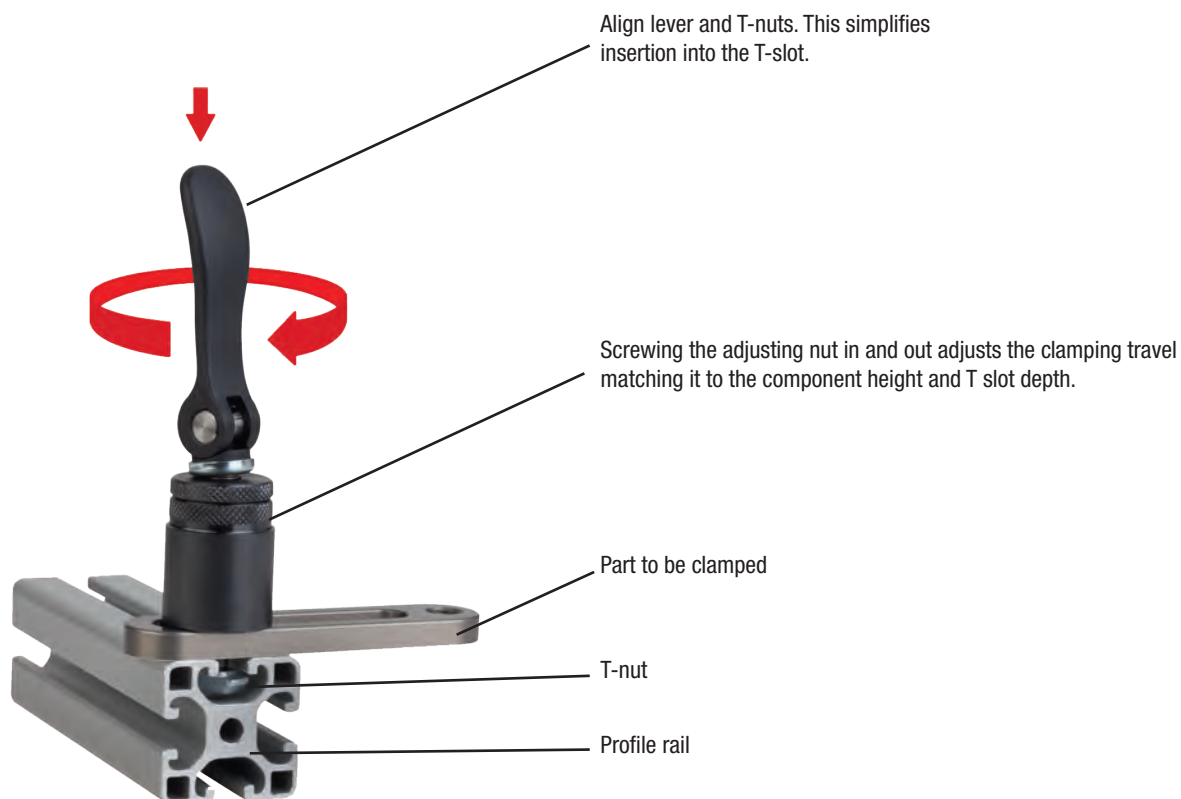

Swivel down to clamp

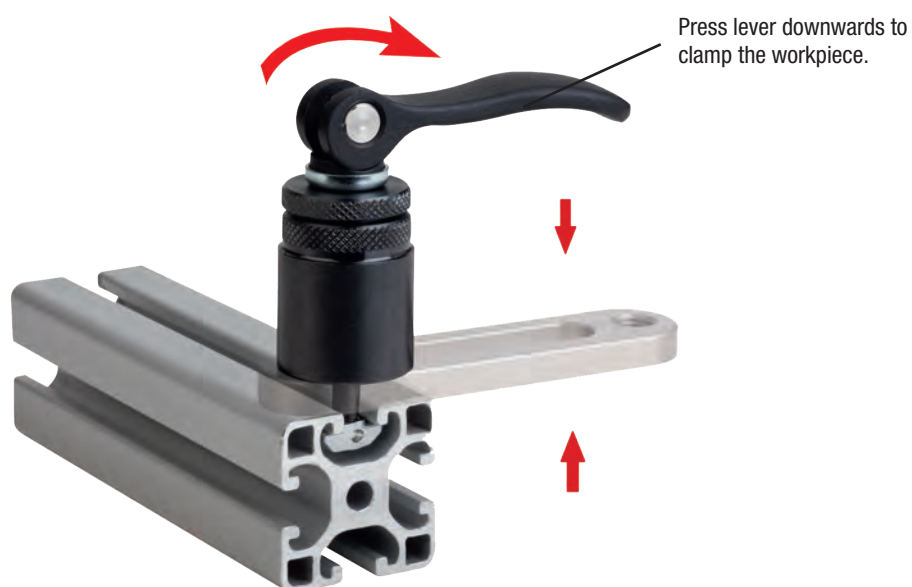

Eccentric clamp modules



Material:
Body steel. Cam levers cast aluminium.

Version:
Body black oxidised. T-nut galvanized.
Cam levers black powder coated.

Sample order:
K0754.00200808

Note:
The clamping module is inserted into the T-slot from above and secured using the cam lever, no other tools required.

Advantages:
The eccentric clamping modules can be used on conventional aluminium profile systems or on T-slot tables as stops, fasteners or clamps for components and workpieces.

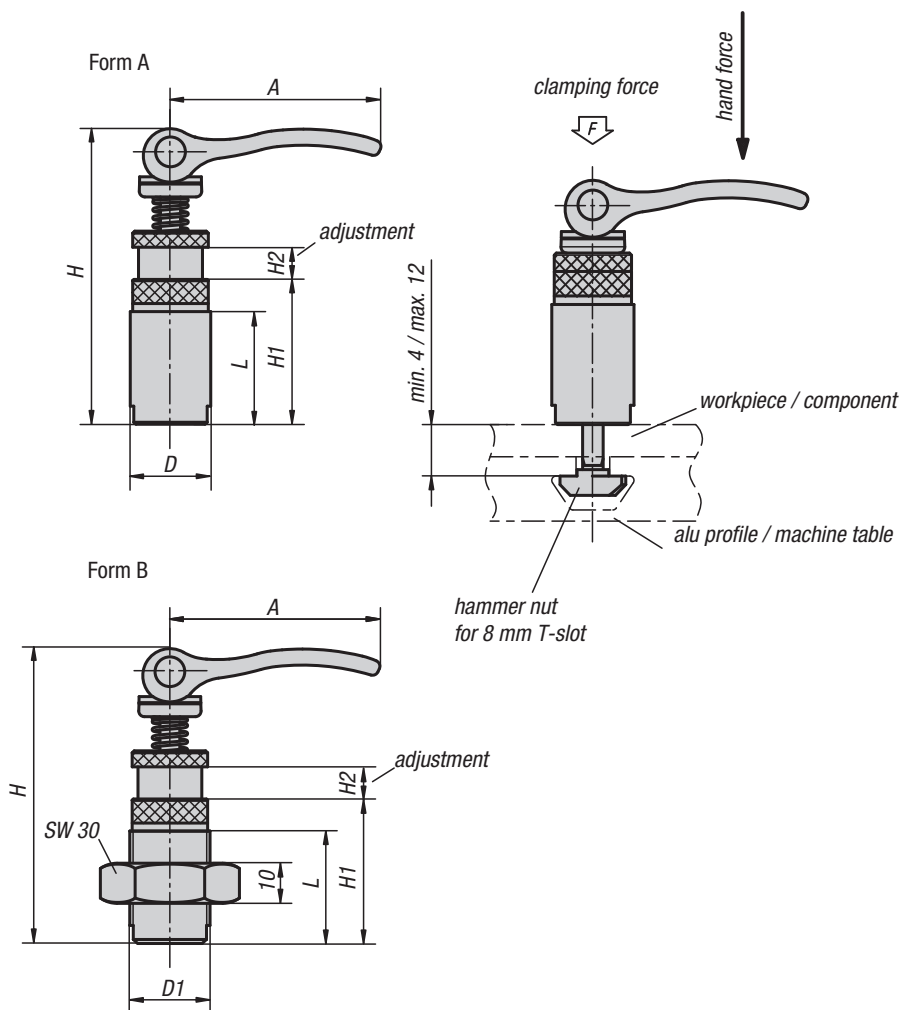

KIPP Eccentric clamp modules

Order No.	Form	D	D1	A	H	H1	H2	L	Clamping force F (kN)	Hand force N
K0754.00200808	A	20	-	52,3	73,5	36	8	28	2,5	100
K0754.10200808	B	-	M20x1,5	52,3	73,5	36	8	28	2,5	100

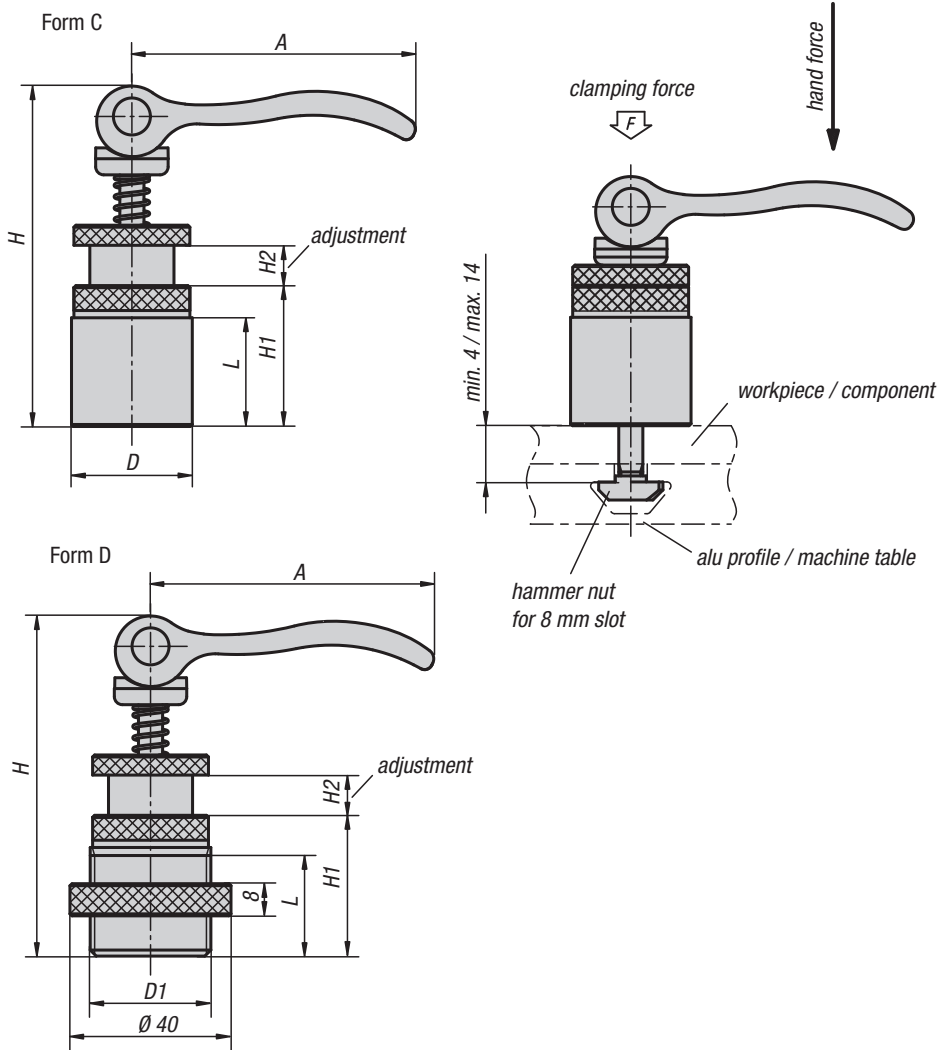

KIPP Eccentric clamp modules

Order No.	Form	D	D1	A	H	H1	H2	L	Clamping force F (kN)	Hand force N
K0754.21301008	C	30	-	70,4	84,6	35	10	25	4	120
K0754.31301008	D	-	M30x2	70,4	84,6	35	10	25	4	120

Clamp straps

slotted heel

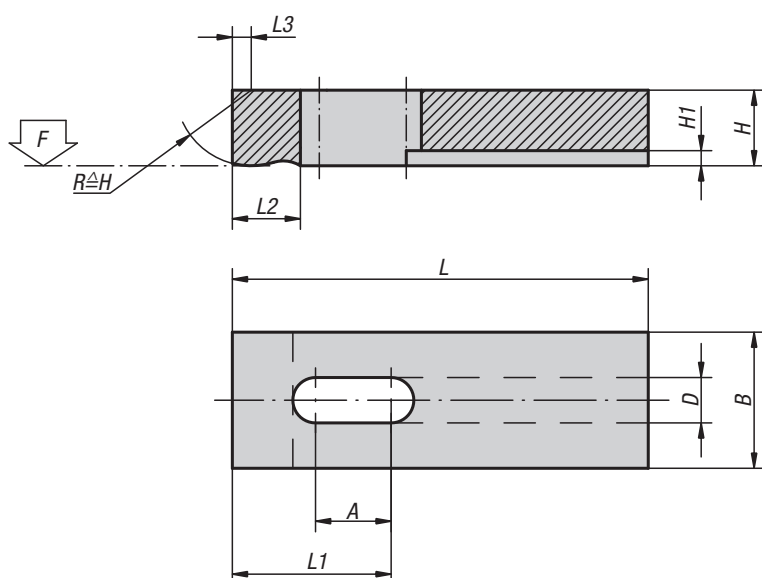

Material:

Carbon steel 1.1191

Version:

Black oxidised.

Sample order:

K0001.101

Note:

For suitable supports and rest pads see K0305 and K0306.

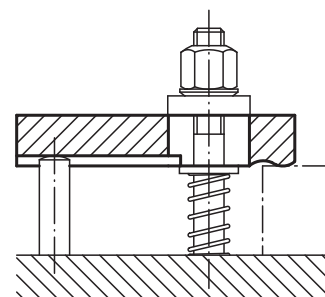

KIPP Clamp straps, slotted heel

Order No.	A	B	D	H	H1	L	L1	L2	L3	F kN
K0001.05	8	12	5,5	8	3	32	14	8	1,2	3,42
K0001.06	10	16	7	10	3	40	17	10	1,6	4,82
K0001.08	12	20	9	12	4	50	22	12	2	8,77
K0001.10	16	25	11	16	4,5	63	28	16	2,5	13,9
K0001.12	20	32	14	20	5	80	35	20	3	20,2
K0001.14	25	40	16	25	6	100	44	25	4	27,6
K0001.16	42	50	18	30	6	160	73	32	5	37,8
K0001.20	52	60	22	30	8	200	92	40	6	58,8
K0001.051	13	12	5,5	8	3	50	23	8	1,2	3,42
K0001.061	17	16	7	10	3	63	29	10	1,6	4,82
K0001.081	21	20	9	12	4	80	37	12	2	8,77
K0001.101	26	25	11	16	4,5	100	46	16	2,5	13,9
K0001.121	33	32	14	20	5	125	58	20	3	20,2
K0001.141	42	40	16	30	6	160	74	25	4	27,6

Clamp straps

assorted, long slot



K0002.01 (0,5 kg)

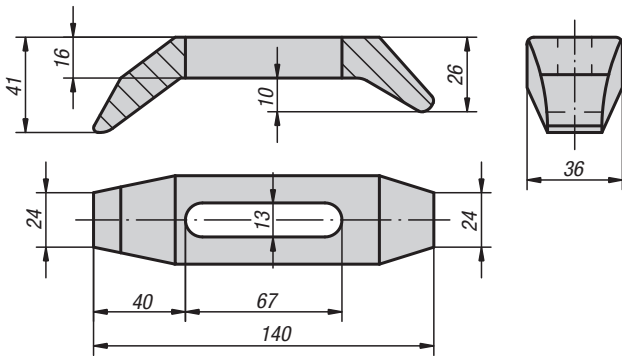

K0002.05 (0,48 kg)

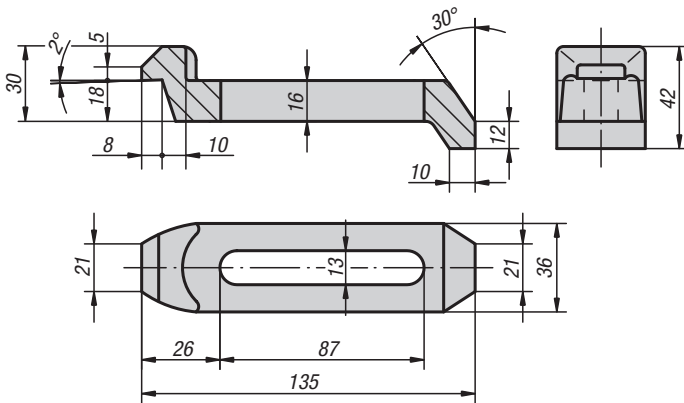

K0002.10 (0,35 kg)

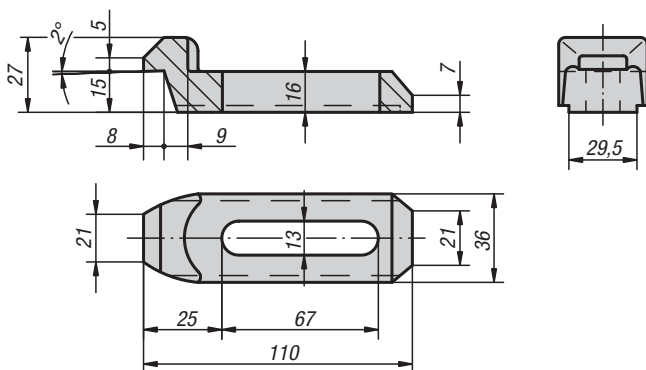

Material:

Carbon steel 1.7225

Version:

Tempered to 1000 N/mm², black oxidised.

Sample order:

K0002.10

Note:

These clamp straps with long slot are also used with the compact clamp strap module K0004.

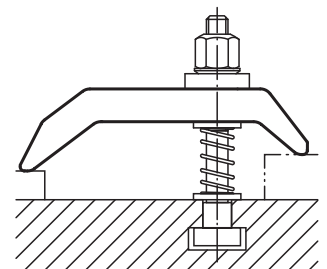

KIPP Clamp straps, assorted, long slot

Order No.	Article description
K0002.01	GOOSE-NECK STRAP
K0002.05	GOOSE-NECK STRAP
K0002.10	GOOSE-NECK STRAP

Clamp strap assemblies

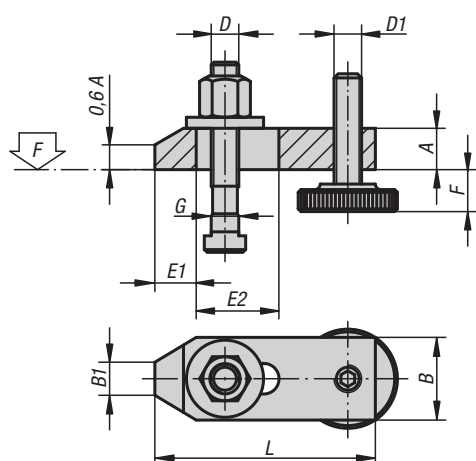
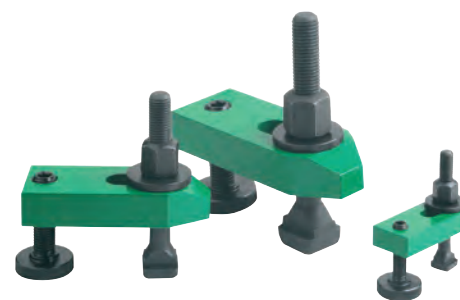

Material:

Carbon steel.
Screws tempered to 8.8.

Version:

Clamp painted. Screws black oxidised.

Sample order:

K0003.1616

Note:

"F" is dependent on the depth of slot according to DIN 650.

KIPP Clamp strap assemblies

Order No.	L	A	B	B1	E1	E2	F	G for T-slot	D	D1	F kN
K0003.1010	80	15	30	12	15	30	8-32	10	M10x80	M10	13,9
K0003.1212	100	20	40	14	21	40	10-40	12	M12x100	M12	20,2
K0003.1214	100	20	40	14	21	40	10-38	14	M12x100	M12	20,2
K0003.1616	125	25	50	18	26	45	13-49	16	M16x125	M16	37,8
K0003.1618	125	25	50	18	26	45	13-46	18	M16x125	M16	37,8
K0003.2020	160	30	60	22	30	60	16-65	20	M20x160	M20	58,8
K0003.2022	160	30	60	22	30	60	16-65	22	M20x160	M20	58,8

Clamp straps

with adjustment unit



Material:

Base, ductile iron.

Clamp strap and clamping screw carbon steel.

Version:

Black oxidised.

Sample order:

K0004.40X16 (include dimension B)

Note:

These clamp strap modules are universal, flexible clamps constructed from individual components building a compact unit. There are no loose parts which first have to be altered for a clamping operation. The compact design allows these clamps to be placed close to the workpiece allowing the full area of the machine table can be used.

Size 1

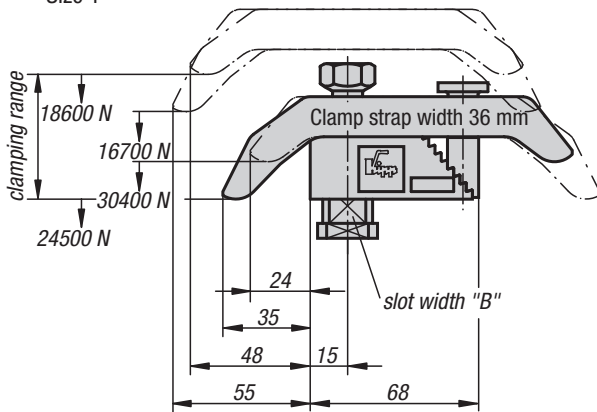

Size 2

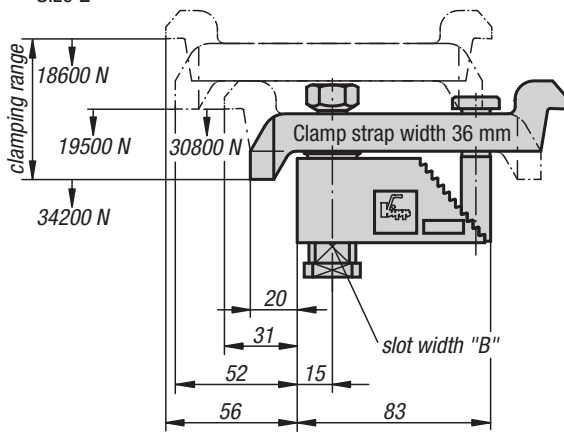

Size 3-5

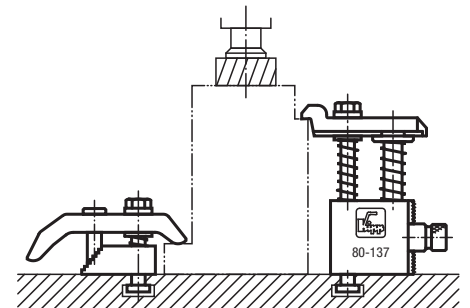
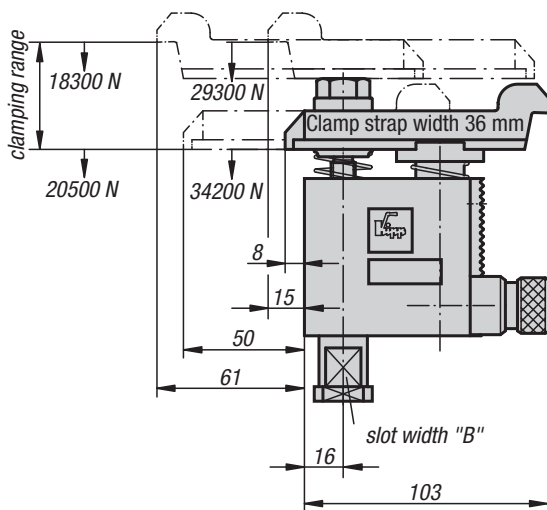

KIPP Clamp straps with adjustment unit

Order No.	Size	Clamp range	Slot width B to DIN 650
K0004.10X	1	0-35	12/14/16/18
K0004.20X	2	25-85	12/14/16/18
K0004.30X	3	80-137	12/14/16/18
K0004.40X	4	125-224	12/14/16/18
K0004.50X	5	160-300	12/14/16/18

Hinge pins



Material:
Carbon steel 1.0503.07

Version:
Tempered. Ground, bright.

Sample order:
K0007.08

Note:
For use with:
Cam levers K0008 and K0009.
Eye bolts K0396.
Clevis K0397.
Circlips supplied.

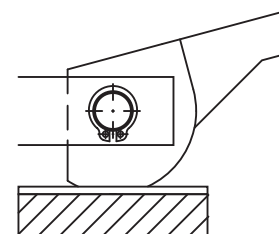
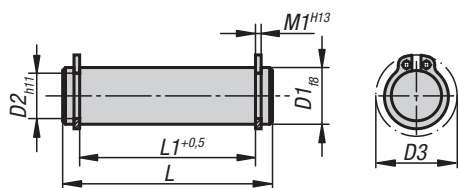

KIPP Hinge pins

Order No.	D1	L	L1	M1	D2	D3
K0007.05	5	18	13	0,7	4,8	10,7
K0007.06	6	22	17	0,8	5,7	12,2
K0007.08	8	30	25	0,9	7,6	15,2
K0007.081	8	20	16	0,9	7,6	15,2
K0007.082	8	27	21	0,9	7,6	15,2
K0007.10	10	37	32	1,1	9,6	17,6
K0007.101	10	25	20	1,1	9,6	17,6
K0007.102	10	35	29	1,1	9,6	17,6
K0007.12	12	46	40	1,1	11,5	19,6
K0007.121	12	31	25	1,1	11,5	19,6
K0007.122	12	37	31	1,1	11,5	19,6
K0007.14	14	44	37	1,1	13,4	22
K0007.16	16	48	41	1,1	15,2	24,4
K0007.18	18	58	51	1,3	17	26,8

Cam levers

single

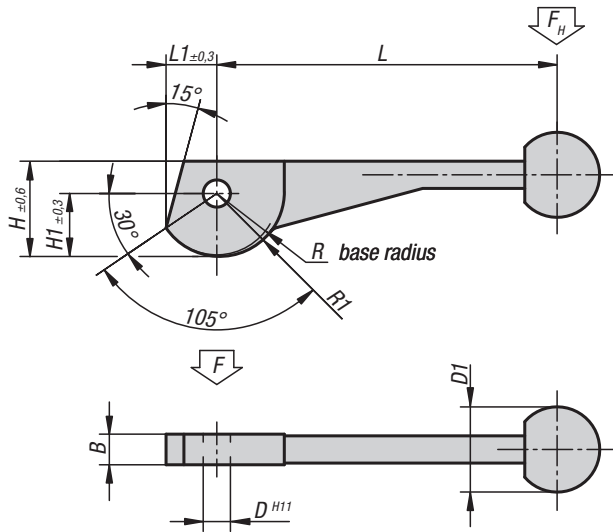

Material:

Carbon steel 1.7220.

Plastic ball.

Version:

Tempered and black oxidised.

Sample order:

K0008.10

Note:

Suitable hinge pin, see K0007.

The cam lever is an eccentric lever that moves along a logarithmic spiral. Its clamping properties are even over the entire contact surface of the cam.



Force diagram

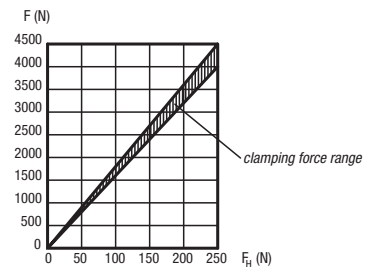

KIPP Cam levers, single

Order No.	L	L1	B	H	H1	D	D1	R	R1
K0008.08	104±2	14,9	9	28,2	18,7	8	25	17,2	19,2
K0008.10	123±2	18,6	12	34,8	23,3	10	30	21,5	24
K0008.12	146±3	24,3	14	43,8	30,3	12	30	28	31,2

Cam levers

double



Material:

Carbon steel 1.7220.
Plastic ball.

Version:

Tempered and black oxidised.

Sample order:

K0009.12

Note:

Suitable hinge pin, see K0007.

The cam lever is an eccentric lever that moves along a logarithmic spiral. Its clamping properties are even over the entire contact surface of the cam.

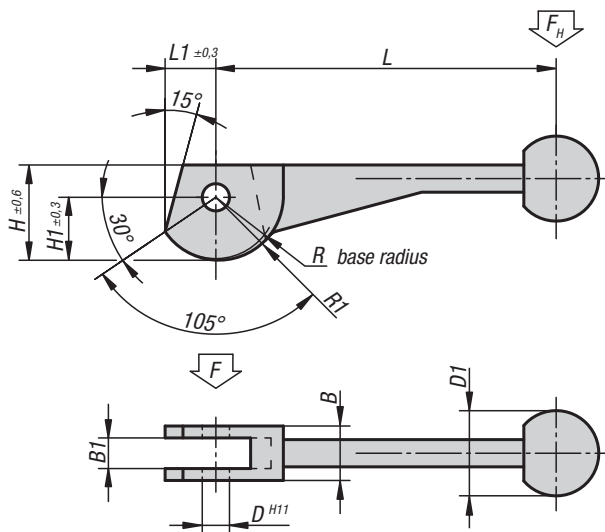

Force diagram

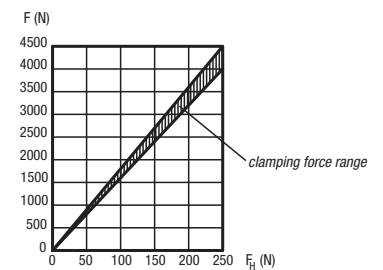

KIPP Cam levers, double

Order No.	L	L1	B	B1	H	H1	D	D1	R	R1
K0009.08	104±2	14,9	16	9	28,2	18,7	8	25	17,2	19,2
K0009.10	123±2	18,6	20	12	34,8	23,3	10	30	21,5	24
K0009.12	146±3	24,3	25	14	43,8	30,3	12	30	28	31,2

Cam clamps

single



Material:
Cam lever carbon steel 1.7220.
Strap carbon steel 1.1191.

Version:
Black oxidised.

Sample order:
K0010.10

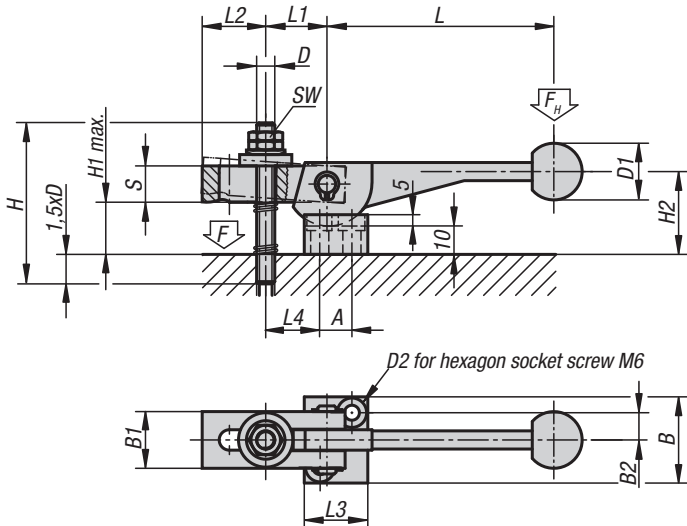

Force diagram

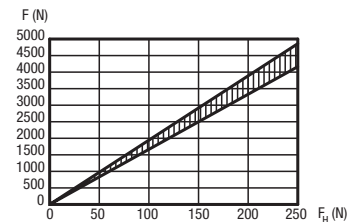

KIPP Cam clamps, single

Order No.	L	L1	L2	L3	L4	B	B1	B2	S	H	H1 max.	H2	D	D1	D2	A	SW
K0010.08	104±2	27	28	28	27	38	25	12	16	70	25	34	M8	25	7	14	13
K0010.10	123±2	34	36	32	35	41	32	13,5	20	80	24	40	M10	30	7	16	17
K0010.12	146±3	43	45	37	45	43	40	14,5	25	100	31	48	M12	30	7	19	19

Cam clamps

double



Material:

Cam lever carbon steel 1.7220.
Strap carbon steel 1.1191

Version:

Black oxidised.

Sample order:

K0011.12

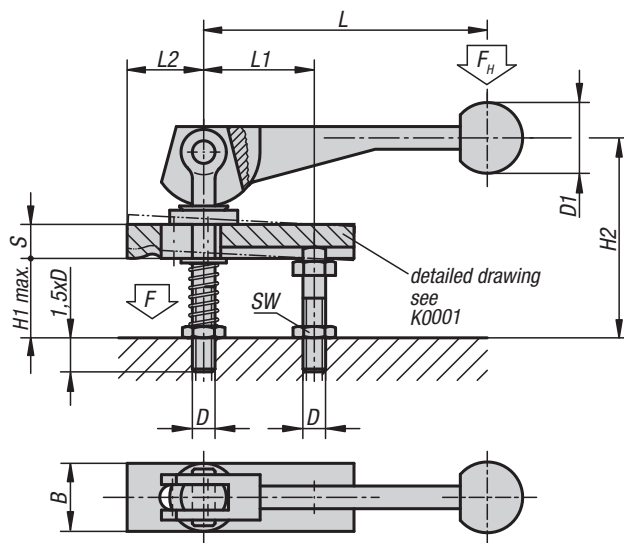

Force diagram

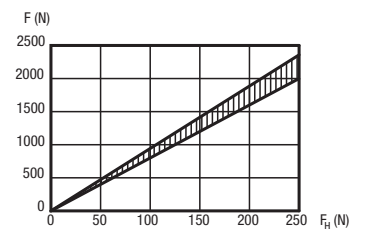

KIPP Cam clamps, double

Order No.	L	L1	L2	B	S	H1 max.	H2	D	D1	SW
K0011.08	104±2	39	37	20	12	28	74	M8	25	13
K0011.10	123±2	49	46	25	16	39	92	M10	30	17
K0011.12	146±3	61	58	32	20	49	120	M12	30	19

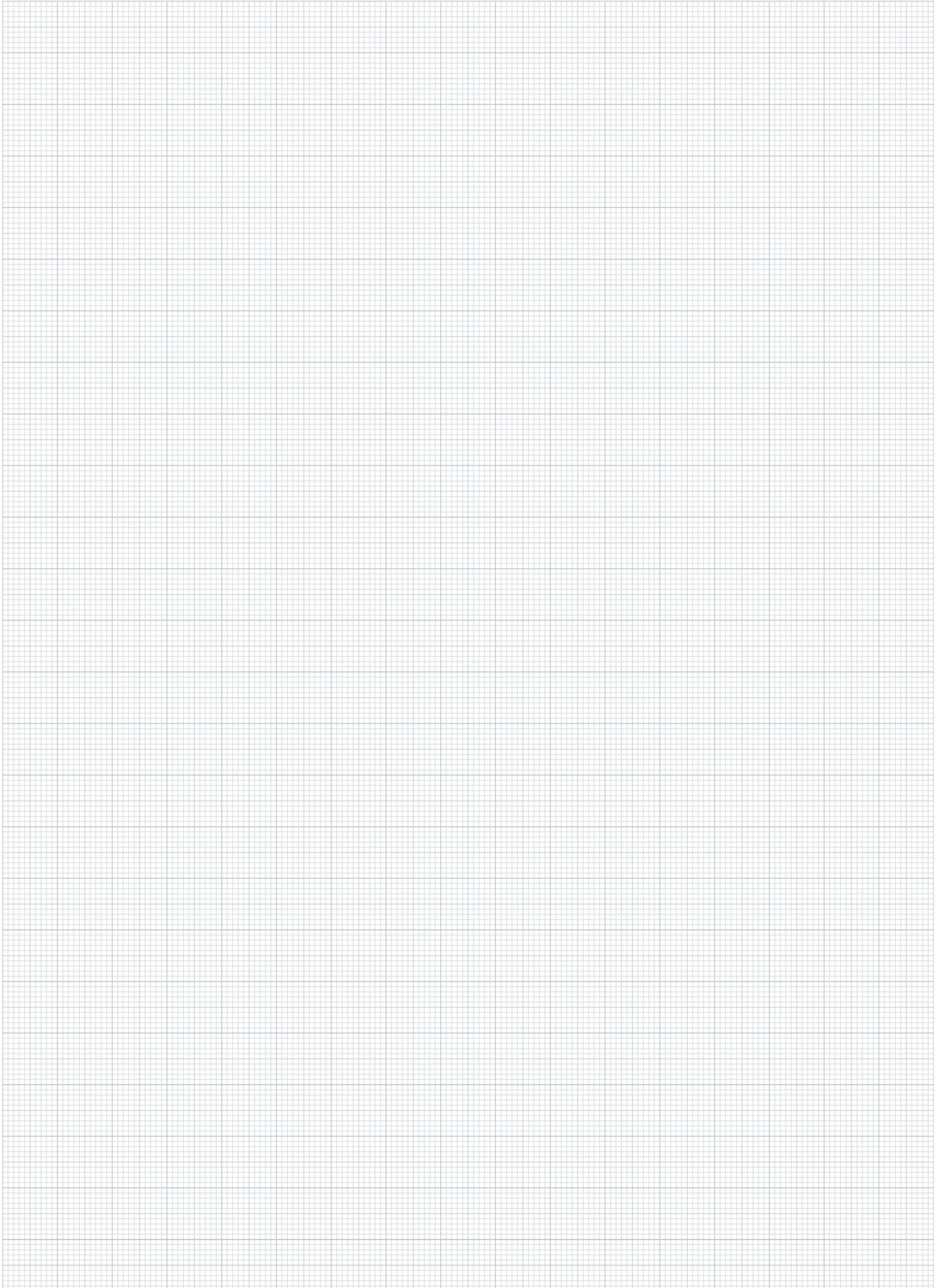

Hook clamps



Material:
Carbon steel, tempered.

Version:
Black oxidised.

Sample order:
K0012.10

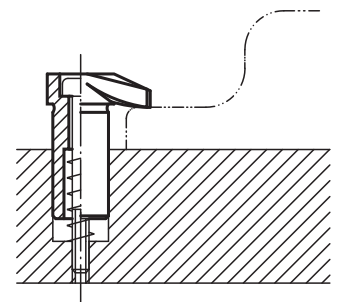
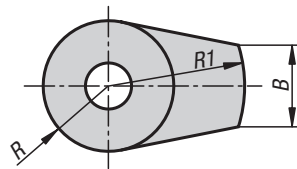
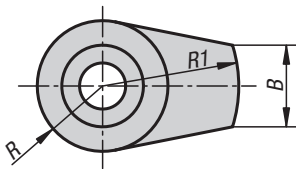
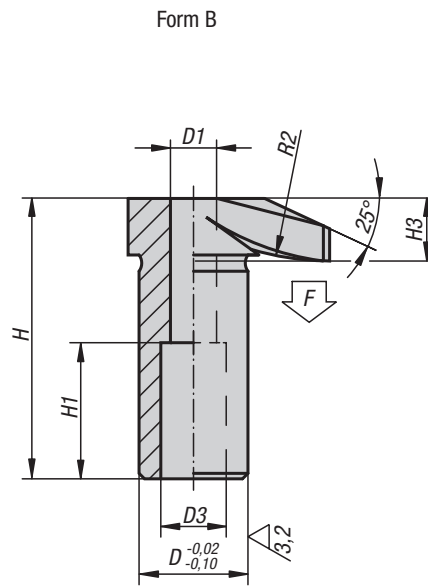
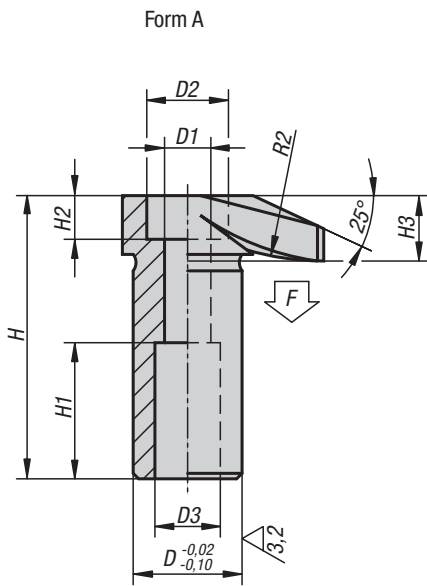

KIPP Hook clamps

Order No.	Form	D	D1	D2	D3	H	H1	H2	H3	B	R	R1	R2	F max. kN
K0012.06	A	16	6,5	11	10	42	20	6	10	11	9	20	30	4,8
K0012.08	A	20	8,5	15	12	52	25	8	12	15	12	25	50	8,8
K0012.10	A	25	10,5	18	14	66	32	10	16	17	14	32	60	13,9
K0012.12	A	32	12,5	20	17	83	40	12	20	20	18	40	80	20,2

Order No.	Form	D	D1	D3	H	H1	H3	B	R	R1	R2	F max. kN
K0012.106	B	16	6,5	10	41,5	20	9,5	11	9	20	30	4,8
K0012.108	B	20	8,5	12	51,5	25	11,5	15	12	25	50	8,8
K0012.110	B	25	10,5	14	65,5	32	15,5	17	14	32	60	13,9
K0012.112	B	32	12,5	17	82,5	40	19,5	20	18	40	80	20,2

Hook clamps

with protective insert

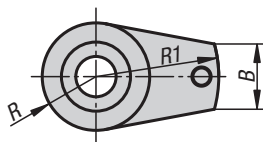
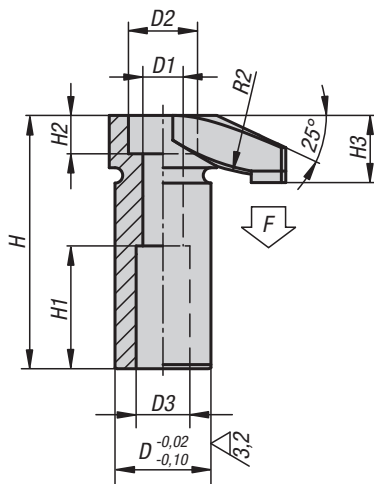

Material:

Carbon steel.

Inserts POM or polyurethane 99A.

Version:

Tempered and black oxidised.

Sample order:

K0012.206

Note:

The pressed in plastic inserts offer optimal damage protection for sensitive workpiece faces.

KIPP Hook clamps with protective insert

Order No.	Form	Version	D	D1	D2	D3	H	H1	H2	H3	B	R	R1	R2	F max. kN
K0012.206	A	POM protective insert	16	6,5	11	10	42	20	6	10,5	11	9	20	30	4,8
K0012.208	A	POM protective insert	20	8,5	15	12	52	25	8	13,5	15	12	25	50	8,8
K0012.210	A	POM protective insert	25	10,5	18	14	66	32	10	17,5	17	14	32	60	11,6
K0012.2106	B	POM protective insert	16	6,5	-	10	41,5	20	-	10	11	9	20	30	4,8
K0012.2108	B	POM protective insert	20	8,5	-	12	51,5	25	-	13	15	12	25	50	8,8
K0012.2110	B	POM protective insert	25	10,5	-	14	65,5	32	-	17	17	14	32	60	11,6
K0012.2112	B	POM protective insert	32	12,5	-	17	82,5	40	-	21	20	18	40	80	18,8
K0012.212	A	POM protective insert	32	12,5	20	17	83	40	12	21	20	18	40	80	18,8
K0012.306	A	Polyurethane protective insert	16	6,5	11	10	42	20	6	10,5	11	9	20	30	4,8
K0012.308	A	Polyurethane protective insert	20	8,5	15	12	52	25	8	13,5	15	12	25	50	8,8
K0012.310	A	Polyurethane protective insert	25	10,5	18	14	66	32	10	17,5	17	14	32	60	11,6
K0012.3106	B	Polyurethane protective insert	16	6,5	-	10	41,5	20	-	10	11	9	20	30	4,8
K0012.3108	B	Polyurethane protective insert	20	8,5	-	12	51,5	25	-	13	15	12	25	50	8,8
K0012.3110	B	Polyurethane protective insert	25	10,5	-	14	65,5	32	-	17	17	14	32	60	11,6
K0012.3112	B	Polyurethane protective insert	32	12,5	-	17	82,5	40	-	21	20	18	40	80	18,8
K0012.312	A	Polyurethane protective insert	32	12,5	20	17	83	40	12	21	20	18	40	80	18,8

Hook clamps

with collar



Material:
Carbon steel.

Version:
Tempered and black oxidised.

Sample order:
K0013.06

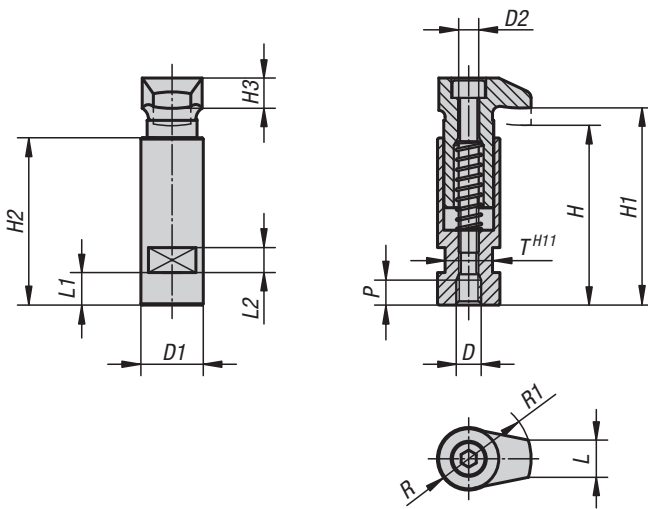

KIPP Hook clamps with collar

Order No.	D	D1	D2	H	H1	H2	H3	L	L1	L2	P	R	R1	T	Clamping force kN
K0013.06	M6	20	6	56	60	53	10	11	9	8	8	9	20	17	4,82
K0013.08	M8	20	6	56	60	53	10	11	9	8	8	9	20	17	8,77
K0013.10	M10	25	8	72	79	67	12	15	13	10	10	12	25	19	13,9
K0013.12	M12	32	10	88	96	82	16	17	18	12	12	14	32	27	20,2
K0013.16	M16	40	12	109	118	102	20	20	22	12	16	18	40	32	37,8

Hook clamps ground

Form A/B/C

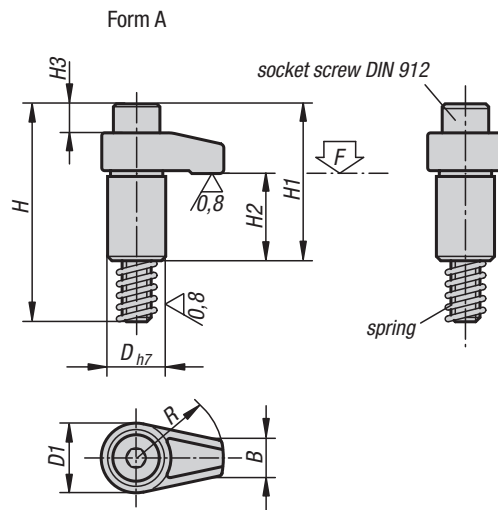

Material:
Carbon steel, tempered.

Version:
Black oxidised. Shaft OD ground.

Sample order:
K0014.216040

Note:
The stated clamping forces (F max.) and tightening torques are valid within the stated clamping ranges (H5).

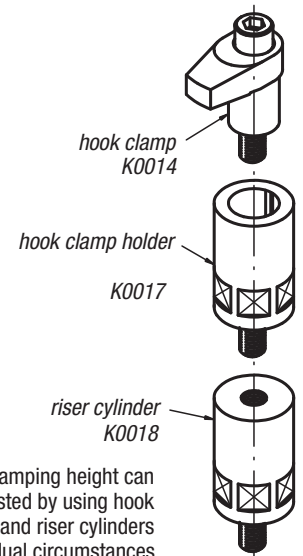
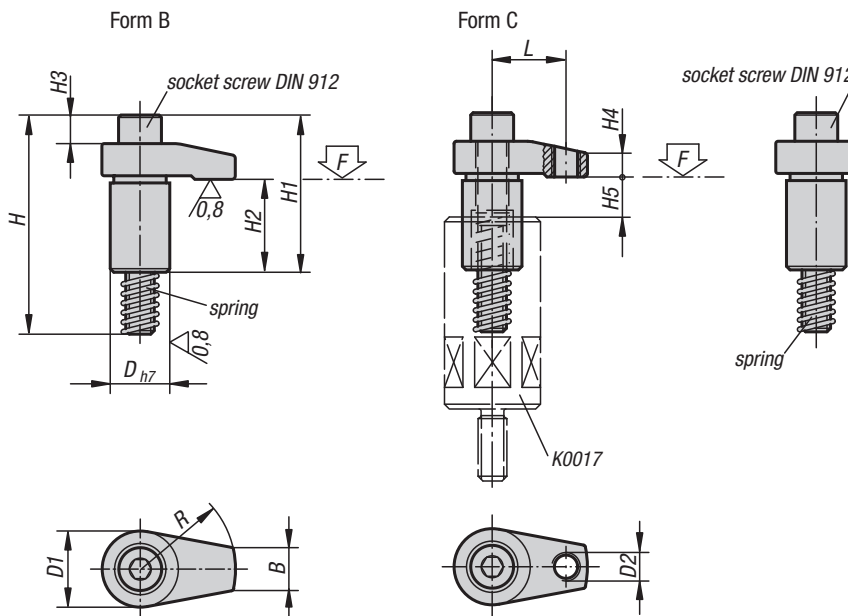

The clamping height can be adjusted by using hook clamp holders and riser cylinders to suit individual circumstances.

KIPP Hook clamps, ground, Form A/B/C

Order No.	Form	D	D1	D2	H	H1	H2	H3	H4	H5 max. clamping range	B	L	R	Socket head screw DIN 912	Tightening torque max. Nm	F max. kN
K0014.110030	A	20	25	-	75	54	30	9	10	12	12	-	30	M10x65	37,2	13
K0014.110040	A	20	25	-	75	54	30	9	10	12	12	-	40	M10x65	31,4	9,8
K0014.208020	B	18	22	-	58	37	23	2	7	10	10	-	20	M8x50	37,2	13,6
K0014.208025	B	18	22	-	58	37	23	2	7	10	10	-	25	M8x50	32,3	10,9
K0014.208030	B	18	22	-	58	37	23	2	7	10	10	-	30	M8x50	29,4	9
K0014.212040	B	25	32	-	92	66	39	11	12	15	18	-	40	M12x80	58,8	17,5
K0014.212050	B	25	32	-	92	68	39	11	12	15	18	-	50	M12x80	49	14
K0014.212060	B	25	32	-	92	68	39	11	12	15	18	-	60	M12x80	45,1	11,6
K0014.216040	B	32	36	-	101	75	39	15	15	15	22	-	40	M16x85	166,6	37,9
K0014.216050	B	32	36	-	101	75	39	15	15	15	22	-	50	M16x85	147	30,4
K0014.216060	B	32	36	-	101	75	39	15	15	15	22	-	60	M16x85	127,4	25,2
K0014.312140	C	25	32	M12	92	66	39	11	10	15	18	31	40	M12x80	58,8	22,6
K0014.312150	C	25	32	M12	92	68	39	11	13	15	18	38	50	M12x80	49	18,5
K0014.312160	C	25	32	M12	92	68	39	11	13	15	18	46	60	M12x80	45,1	15,2
K0014.316150	C	32	36	M12	101	75	39	15	16	15	22	38	50	M16x85	147	38
K0014.316160	C	32	36	M12	101	75	39	15	16	15	22	46	60	M16x85	127,4	33

Hook clamps

with collar



Material:

Hook clamps and hook clamp holders carbon steel, tempered.

Version:

Black oxidised.

Sample order:

K0015.12060

Note:

Hook clamps with collar can be screwed directly into grid holes etc. without counterbore.
For suitable riser elements, see riser cylinders K0018.

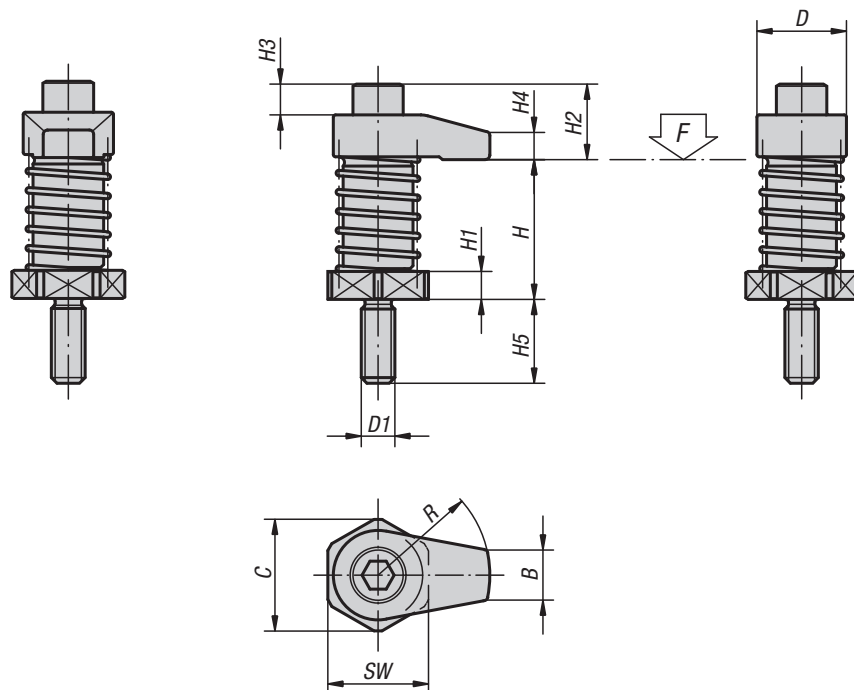

KIPP Hook clamps with collar

Order No.	D	D1	H clamping range	H1	H2	H3	H4	H5	B	C	R	SW	Tightening torque max. Nm	F max. kN
K0015.08020	22	M8	35 - 45	6	14	2	7	19	10	25	20	22	20	7,9
K0015.08025	22	M8	35 - 45	6	14	2	7	19	10	25	25	22	20	7,3
K0015.08030	22	M8	35 - 45	6	14	2	7	19	10	25	30	22	20	6,7
K0015.08120	22	M8	45 - 55	16	14	2	7	19	10	25	20	22	20	7,9
K0015.08125	22	M8	45 - 55	16	14	2	7	19	10	25	25	22	20	7,3
K0015.08130	22	M8	45 - 55	16	14	2	7	19	10	25	30	22	20	6,7
K0015.12040	32	M12	50 - 65	10	27	11	10	30	18	40	40	36	45	13,5
K0015.12050	32	M12	50 - 65	10	29	11	12	30	18	40	50	36	45	12,6
K0015.12060	32	M12	50 - 65	10	29	11	12	30	18	40	60	36	45	11,7
K0015.12140	32	M12	65 - 80	25	27	11	10	30	18	40	40	36	45	13,5
K0015.12150	32	M12	65 - 80	25	29	11	12	30	18	40	50	36	45	12,6
K0015.12160	32	M12	65 - 80	25	29	11	12	30	18	40	60	36	45	11,7
K0015.16040	36	M16	50 - 65	10	36	15	15	30	22	40	40	36	60	13,4
K0015.16050	36	M16	50 - 65	10	36	15	15	30	22	40	50	36	60	12,4
K0015.16060	36	M16	50 - 65	10	36	15	15	30	22	40	60	36	60	12
K0015.16140	36	M16	65 - 80	25	36	15	15	30	22	40	40	36	60	13,4
K0015.16150	36	M16	65 - 80	25	36	15	15	30	22	40	50	36	60	12,4
K0015.16160	36	M16	65 - 80	25	36	15	15	30	22	40	60	36	60	12

Hook clamps with mounting bracket



Material:
Hook clamps and clamping screw carbon steel, tempered.

Version:
Black oxidised.

Sample order:
K0016.12

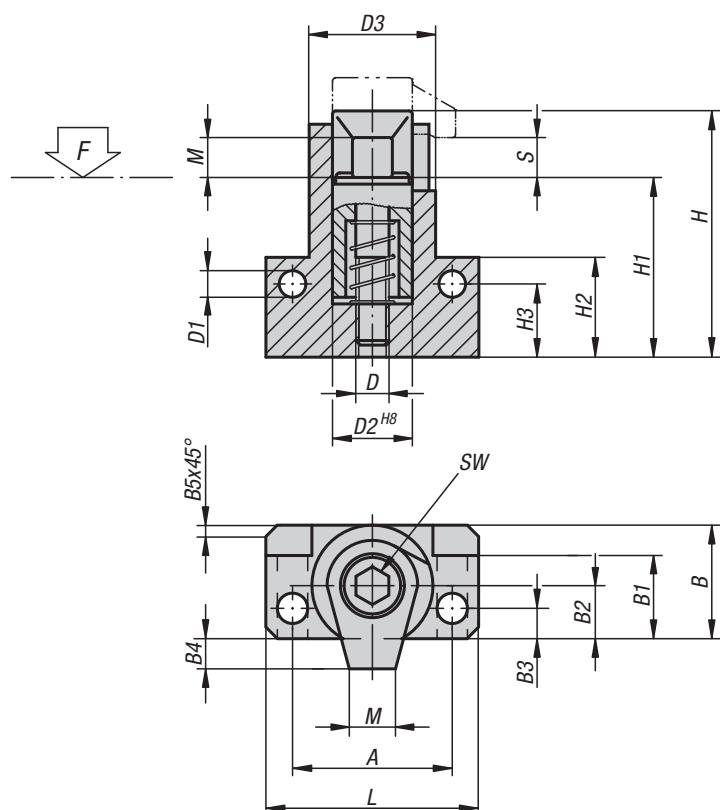

example:

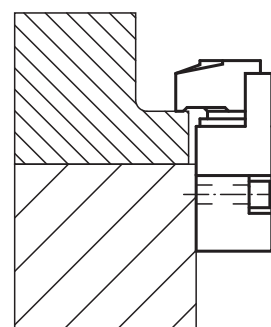

KIPP Hook clamps with mounting bracket

Order No.	D	D1	D2	D3	A	B	B1	B2	B3	B4	B5	H	H1	H2	H3	L	M	S	SW	Tightening torque max. Nm	F max. kN
K0016.08	M8	6,4	20	28	38	26	19,5	12	6	6	2,5	62	47,5	25	18	50	10	4	6	30	17
K0016.10	M10	8,4	24	34	48	31	22,5	14	7,5	9	3	74	57,5	30	21	64	12	5	8	50	18
K0016.12	M12	10,5	28	40	55	36,5	26	16,5	9	10,5	3,5	87	67	35	24	75	15	5	10	60	20
K0016.16	M16	12,8	34	48	65	43,5	31	19,5	10	16,5	4	112	87	45	32	88	20	5	14	120	24

Hook clamp holders



Material:
Carbon steel.

Version:
Black oxidised.

Sample order:
K0017.12080

Note:
Hook clamp holders are for holding and raising hook clamps.

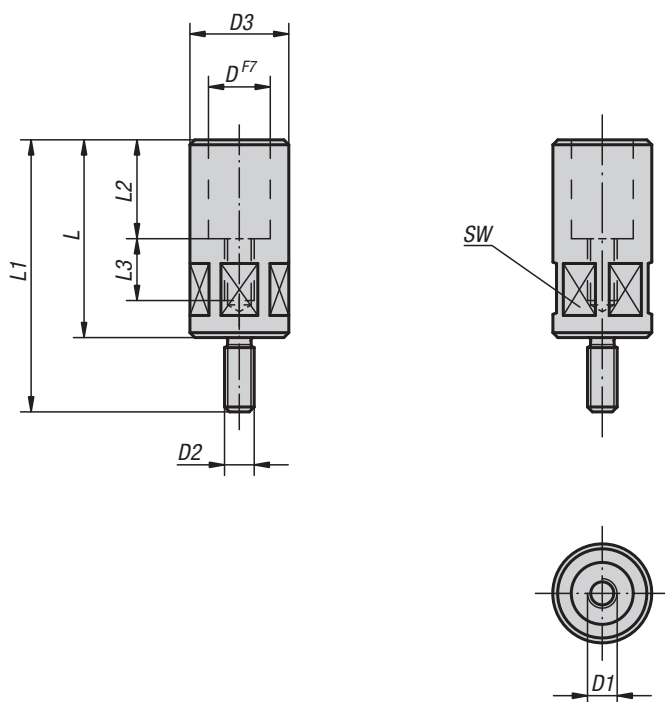

KIPP Hook clamp holders

Order No.	D	D1	D2	D3	L	L1	L2	L3	SW	Tightening torque max. Nm
K0017.08055	18	M8	M8	24	55	74	25	20	22	29,4
K0017.10063	20	M10	M12	32	63	93	30	21	30	39,2
K0017.10080	20	M10	M12	32	80	110	30	23	30	39,2
K0017.12080	25	M12	M12	40	80	110	40	25	36	49
K0017.12100	25	M12	M12	40	100	130	40	28	36	49
K0017.16080	32	M16	M16	50	80	110	40	25	46	78,4
K0017.16100	32	M16	M16	50	100	130	40	28	46	78,4

Riser cylinders



Material:
Carbon steel.

Version:
Black oxidised.

Sample order:
K0018.16050

Note:
The height of the hook clamps and hook clamp holders can be raised with riser cylinders.

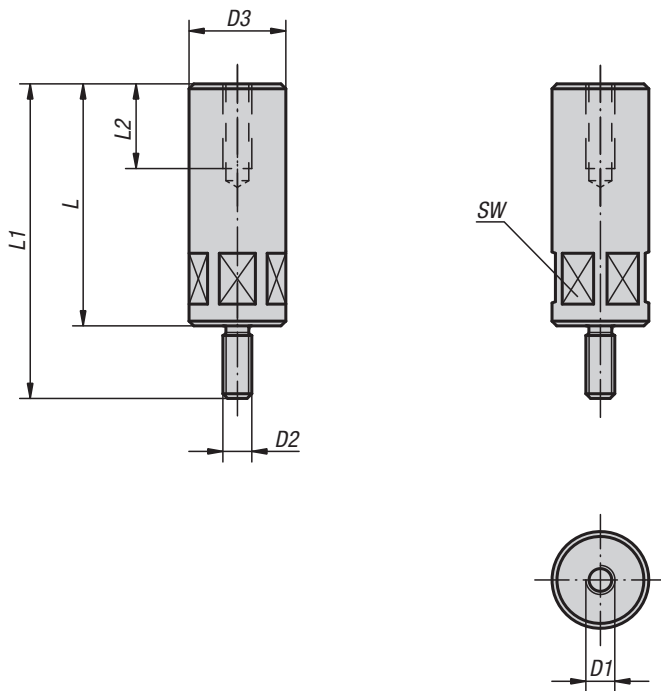

KIPP Riser cylinders

Order No.	D1	D2	D3	L	L1	L2	SW	Tightening torque max. Nm
K0018.08032	M8	M8	24	32	51	20	22	29,4
K0018.08040	M8	M8	24	40	59	20	22	29,4
K0018.08050	M8	M8	24	50	69	20	22	29,4
K0018.08065	M8	M8	24	65	84	20	22	29,4
K0018.12050	M12	M12	40	50	80	35	36	49
K0018.12065	M12	M12	40	65	95	35	36	49
K0018.12080	M12	M12	40	80	110	35	36	49
K0018.12100	M12	M12	40	100	130	35	36	49
K0018.12125	M12	M12	40	125	155	35	36	49
K0018.12160	M12	M12	40	160	190	35	36	49
K0018.12200	M12	M12	40	200	230	35	36	49
K0018.16050	M16	M16	50	50	80	35	46	78,4
K0018.16065	M16	M16	50	65	95	35	46	78,4
K0018.16080	M16	M16	50	80	110	35	46	78,4
K0018.16100	M16	M16	50	100	130	35	46	78,4
K0018.16125	M16	M16	50	125	155	35	46	78,4
K0018.16160	M16	M16	60	160	190	35	55	78,4
K0018.16200	M16	M16	60	200	230	35	55	78,4

Swing clamps



Material:
 Malleable iron body.
 Carbon steel ring 1.1191.
 Carbon steel screw 1.1181.
 Mild steel thrust pad 1.0301.

Version:
 Painted, thrust pads case-hardened.

Sample order:
 K0019.01

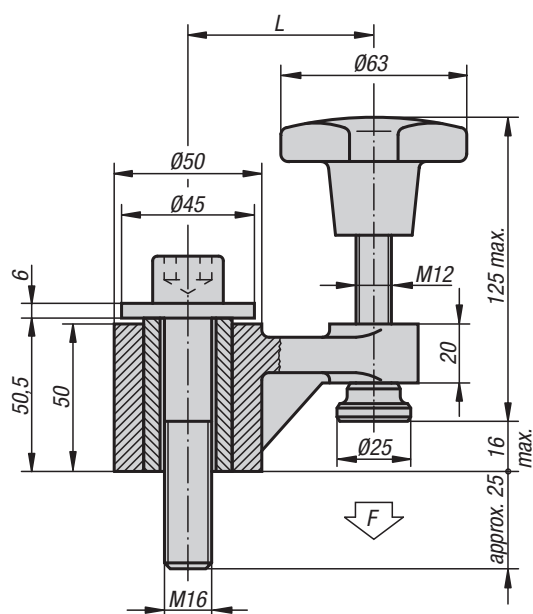

example:

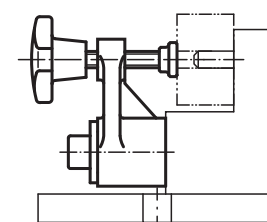

KIPP Swing clamps

Order No.	L	F kN
K0019.01	63	5
K0019.02	100	3

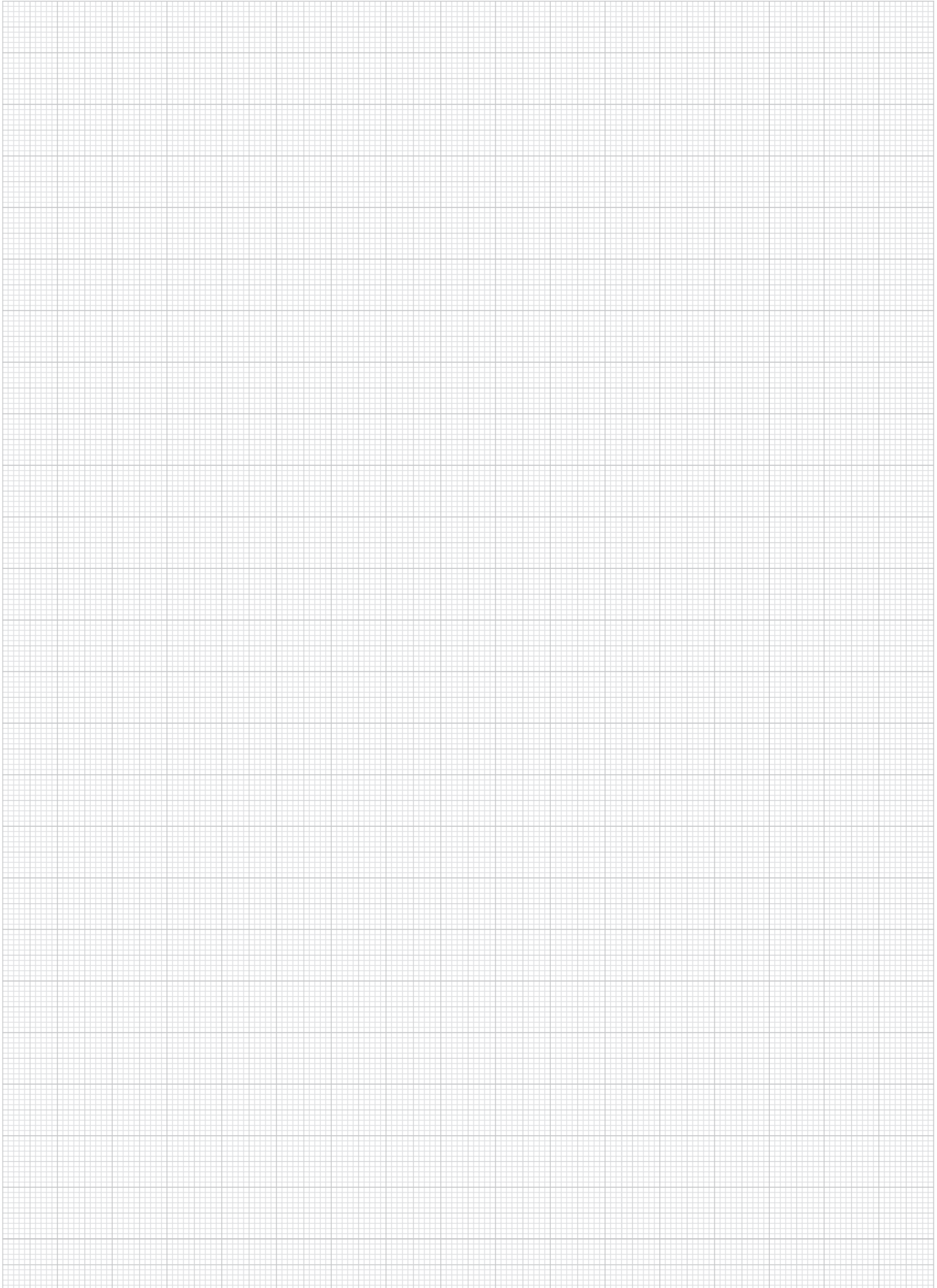

Clamping element "actima"



View from below

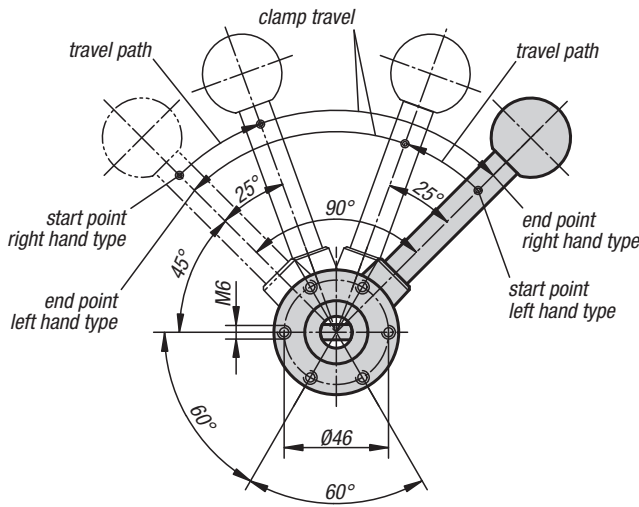

Material:
 Steel.
 Housing thermoplastic.
 Ball knob Duroplast PF 31.
 Accessories steel.

Version:
 Black oxidised.
 Housing black.
 Ball knob, red.
 Accessories black oxidised.

Sample order:
 K0020.10

Note:
 The travel path is 10 mm. Self-locking occurs in any position within only 2 mm of clamp travel. Thus workpieces with tolerances of up to 1.5 mm can be safely clamped. The "actima" clamping device can be fitted in any horizontal or vertical position. Standard parts allow further applications. They are available as optional accessories. All parts of the cam system subject to heavy loads are case-hardened (pressure sleeve and accessories only if specified). The maximum permissible clamping force is approximately 4905 N.

drilled through

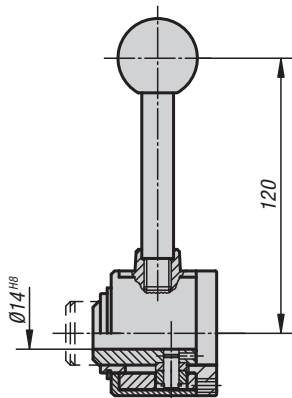

with transverse axis in bore

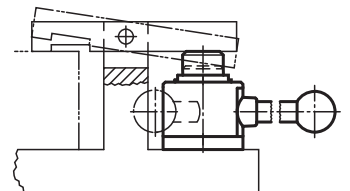
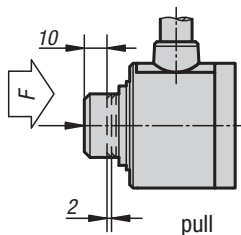
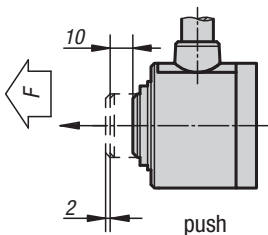
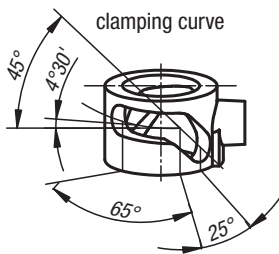
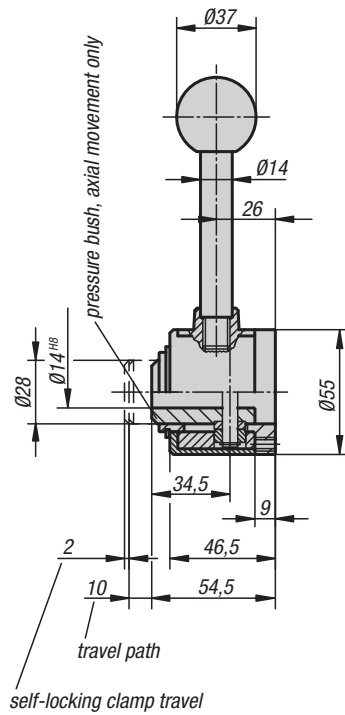

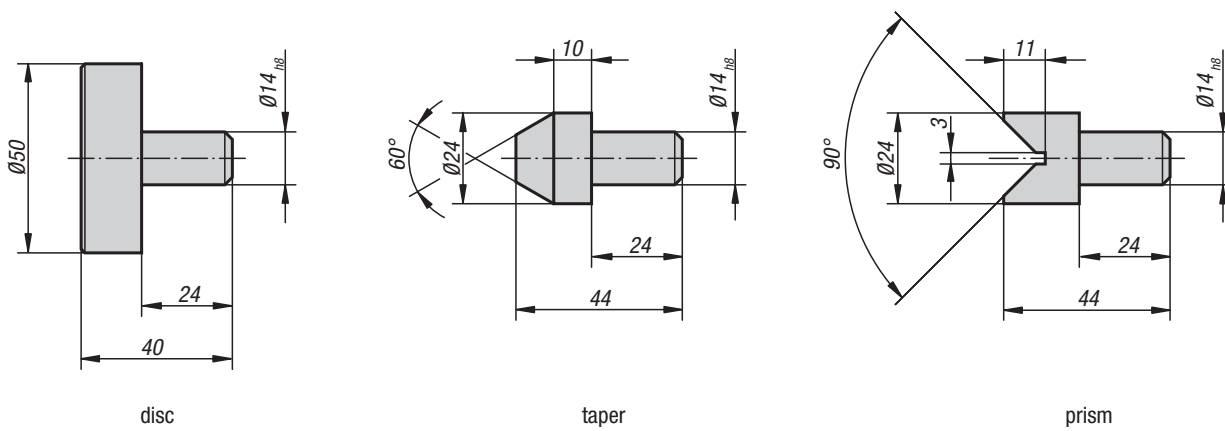

KIPP "actima" clamping device with transverse axis in the hole

Order No.	Version
K0020.10	right-hand / push
K0020.15	right-hand / pull
K0020.20	left-hand / push
K0020.25	left-hand / pull

KIPP "actima" clamping device with through hole

Order No.	Version
K0020.30	right-hand / push
K0020.35	right-hand / pull
K0020.40	left-hand / push
K0020.45	left-hand / pull

KIPP "actima" accessories

Order No.	Article description
K0020.02	DISC
K0020.03	TAPER
K0020.04	PRISM

Clamping element "arness"



Material:
Steel.
Ball knob Duroplast PF 31

Version:
Housing painted silver-grey hammertone.
All other parts and accessories black oxidised.
Ball knob red.

Sample order:
K0021.01

Note:
The travel path is 12 mm. Self-locking occurs in any position within only 1.5 mm of clamp travel, allowing workpieces with tolerances of up to 1 mm to be securely clamped. The "arness" clamping element can be fitted in any horizontal or vertical position. Several standard parts have been developed to achieve individual adaptation for various circumstances and are available as optional accessories. The thrust pad and all parts of the cam system subject to heavy loads are case-hardened. The maximum permissible clamping force is approximately 4905 N.

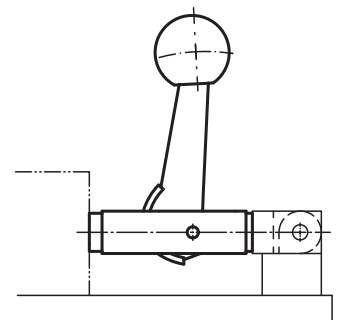
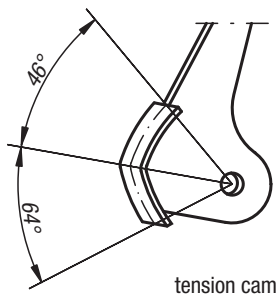
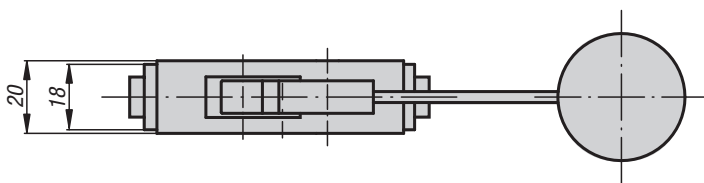
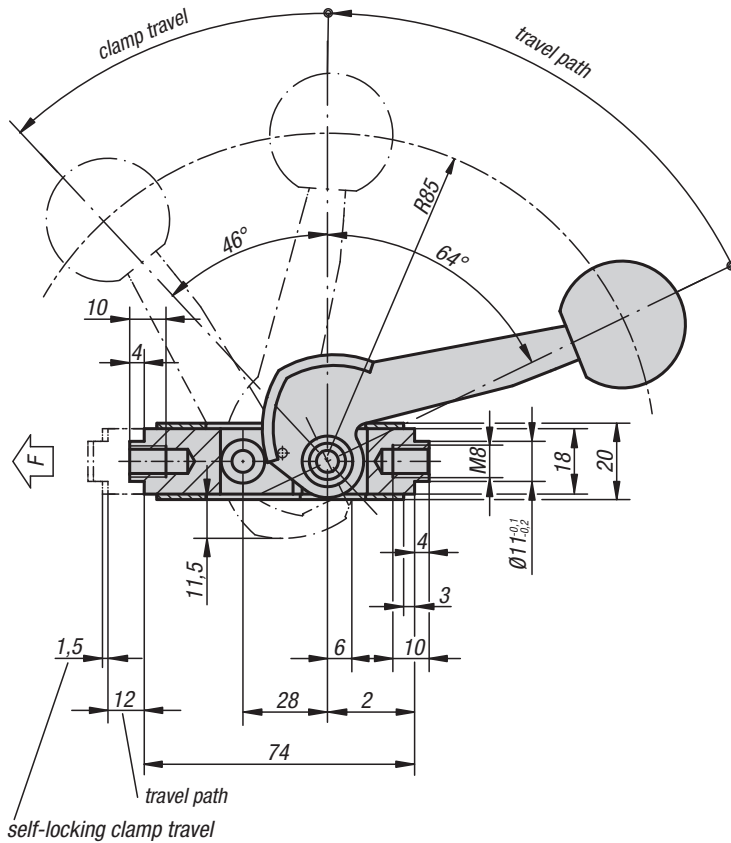

KIPP Clamping element "arness"

Order No.	Dimensions
K0021.01	see drawing

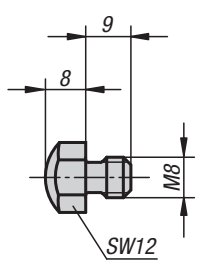

thrust pad

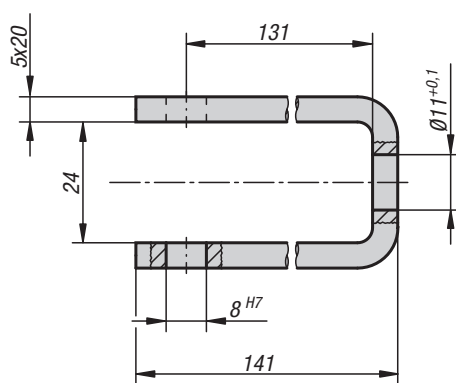

tension bracket

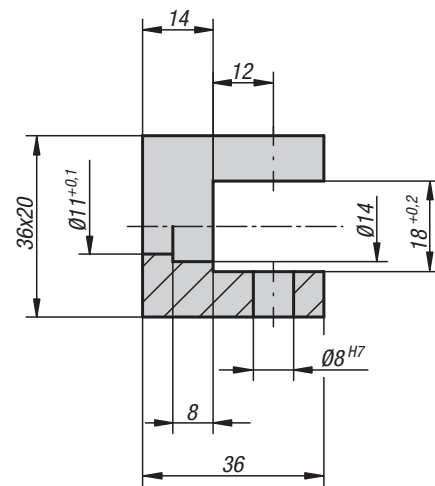

clevis

KIPP "arness" accessories

Order No.	Article description
K0021.02	CLEVIS
K0021.03	TENSION BRACKET
K0021.04	THRUST PAD

Fixture clamps machinable

Material:

Cam screw alloyed steel.
Clamping disc steel.

Version:

Cam screw and clamping disc black oxidised.

Sample order:

K0022.06

Note:

These fixture clamps have a round washer that can be machined to suit the contour of the workpiece being clamped. This allows positive clamping for round, contoured or fragile workpieces. The flat edge is the same distance from the screw centre as our hexagonal fixture clamps K0026 allowing an interchange between the two.

„A“ = distance from workpiece to screw centre (cam screw).

„D1 min.“ = maximum depth of contour.

On request:

Replacement cam screws.

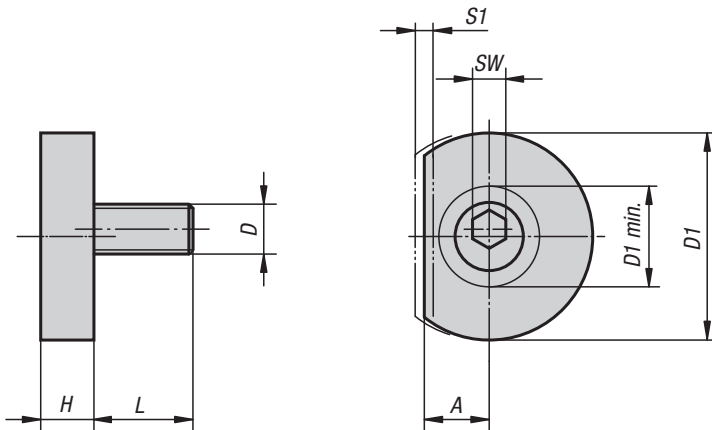

KIPP Fixture clamps machinable

Order No.	A	D	D1	D1 min.	H	L	SW	S1 (travel)	Clamping force kN
K0022.06	7,8	M6	24,9	12,1	6,4	11,9	4	1,01	3,3
K0022.10	10,2	M10	31,2	17,2	8,9	18	7	1,52	8,9
K0022.12	12,7	M12	37,6	22,4	11,4	22,9	8	2,03	17,8
K0022.16	15	M16	43,9	26,1	14	28,6	12	2,54	26,7

Fixture clamps unequal hexagon

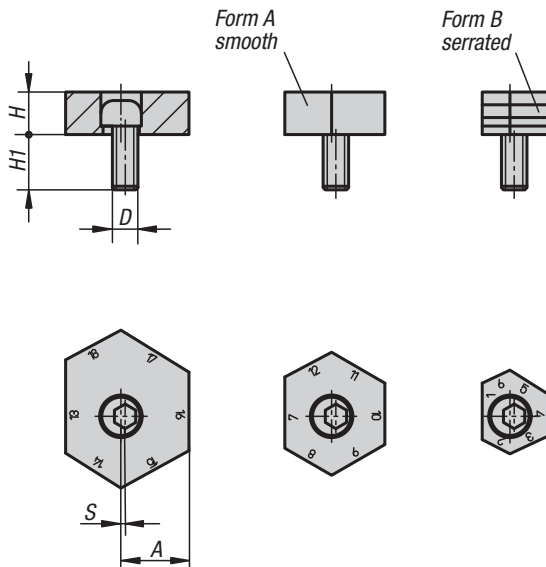
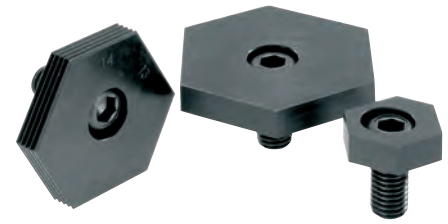

Material:

Cam screw steel tempered to 10.9.
Hexagon washer mild steel.

Version:

Cam screw black oxidised.
Hexagon washer hardened and black oxidised.

Sample order:

K0023.13

Note:

These unequal hexagon fixture clamps can minimise the cost of clamping in fixtures. The clamping range can be altered up to 17 mm from the same tapped hole. Simply rotate the hexagon washer. The washers are available with smooth edges for machined faces or with serrated edges for rough faces.

On request:

Replacement cam screws.

KIPP Fixture clamps unequal hexagon

Order No. Form A	Order No. Form B	Distance A by face No.	D	H	H1	S (cam travel)	Clamping force kN
K0023.09	K0023.13	1/12, 2/13, 3/14, 4/15, 5/16, 6/17	M12	10	22	1	18
K0023.10	K0023.14	7/18, 8/19, 9/20, 10/21, 11/22, 12/23	M12	10	22	1	18
K0023.11	K0023.15	13/24, 14/25, 15/26, 16/27, 17/28, 18/29	M12	10	22	1	18

Spiral cam screws



Material:
Steel.

Version:
Case-hardened (56 ± 1 HRC) and blue galvanized.
Grade 8.8

Sample order:
K0024.0408

Note:
Robust, compact spiral cam clamping screws that exert a positive down force on diverse workpiece forms.

Assembly:
Drill and tap several holes at a distance X or Z (see diagram). Screw the cam screw into the required height and position with the flat side to the workpiece. Position the workpiece and tighten the cam screw with a hexagon key. Full clamping is achieved with approximately a 1/3 rotation. Lubricate the tapped hole regularly.

Place stops on the face towards which the screw turns to prevent the workpiece rotating away.

On request:
Spiral cam screws with LH thread.

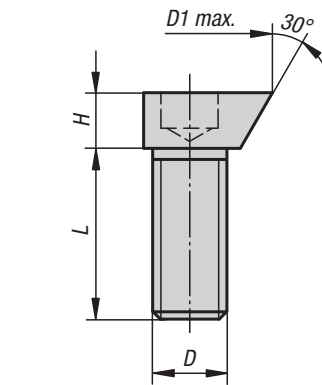

mounting dimensions

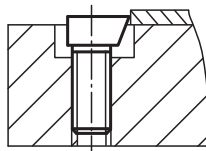
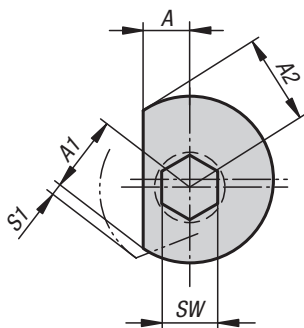
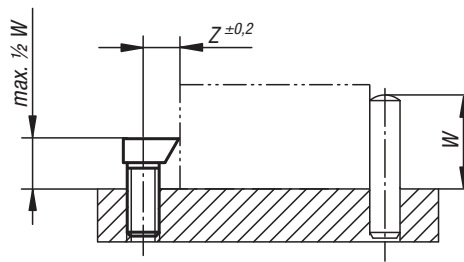
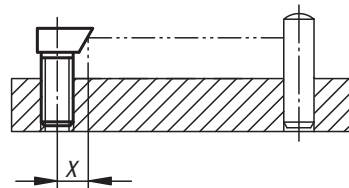

clamping sheet metal

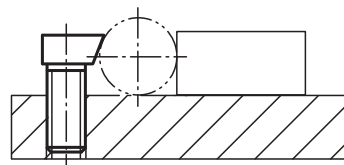

clamping round parts

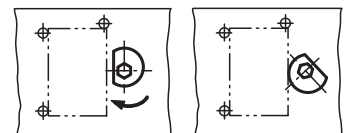

KIPP Spiral cam screws

Order No.	A	A1	A2	D	D1 max.	H	L	SW	S1 (travel)	X	Z	Clamping force kN	Tightening torque max. Nm
K0024.0408	3	4,6	4	M4	9,2	3	8	2,5	0,6	3,5	4,2	0,09	1,5
K0024.0510	3,5	5,7	5	M5	11,4	4	10	3	0,7	4,2	5,2	0,1	2
K0024.0612	4,5	7,1	6,1	M6	14,2	5	12	4	1	5,4	6,4	0,3	4,5
K0024.0816	5,5	8,9	7,7	M8	18	6	16	5	1,2	6,6	8	2,7	20
K0024.1020	6,5	11,1	9,4	M10	22,2	7	20	6	1,7	8,3	9,8	4	30
K0024.1224	8	13,5	11,6	M12	27	9	24	8	1,9	10,1	12	5,4	44

Cam screws

with knife edge washer

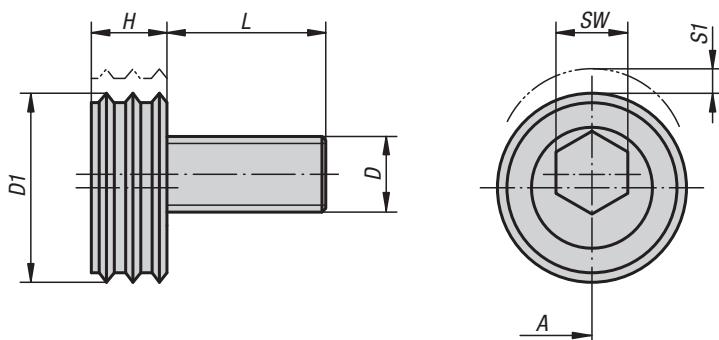

Material:

Knife edge washer.
Cam screw carbon steel.

Version:

Cam screw tempered to 10.9 and black oxidised.
Knife edge washer hardened and anodized.

Sample order:

K0025.16

Note:

The hardened knife edge washer is suitable for clamping rough cut stock, castings, forgings etc.

„A“ = distance from workpiece to screw centre (cam screw).

On request:

Replacement cam screws.

KIPP Cam screws with knife edge washer

Order No.	A	D	D1	L	H	SW	S1 (travel)	Clamping force kN	Tightening torque max. Nm
K0025.12	12,7	M12	25,4	22,5	9,6	8	2	18	88
K0025.16	15	M16	30,1	26,8	12,7	12	2,5	27	135

Cam screws

with hexagon washer



Material:

Cam screw carbon steel.
Hex washer brass.

Version:

Cam screw tempered to 10.9 and black oxidised.

Sample order:

K0026.12

Note:

The minimal height of this fixture clamp allows numerous clamping problems in fixture and equipment construction to be solved. The brass hex washer offers a gentle yet extremely stable and safe clamping of workpieces. By using several fixture clamps entire pallets can be set-up.

„A“ = distance from workpiece to screw centre (cam screw).

On request:

Replacement cam screws.

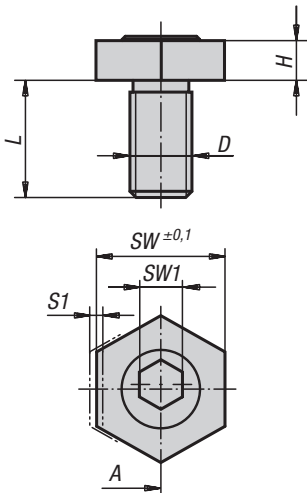

KIPP Cam screws with hexagon washer

Order No.	A	D	H	L	SW	SW1	S1 (travel)	Clamping force kN	Tightening torque max. Nm
K0026.04	3,8	M4	2,8	10	8	3	0,8	0,9	2,2
K0026.06	7,8	M6	4,8	12	16	4	1,3	3,4	8,5
K0026.08	10,2	M8	4,8	15	20	5	1	3,6	11,3
K0026.10	10,2	M10	6,4	20	20	7	1,6	9,0	28,06
K0026.12	12,7	M12	9,5	25	25	8	2	18,0	88
K0026.16	15	M16	12,7	30	30	12	2,5	27,0	135

Application using fixture clamps



Notes

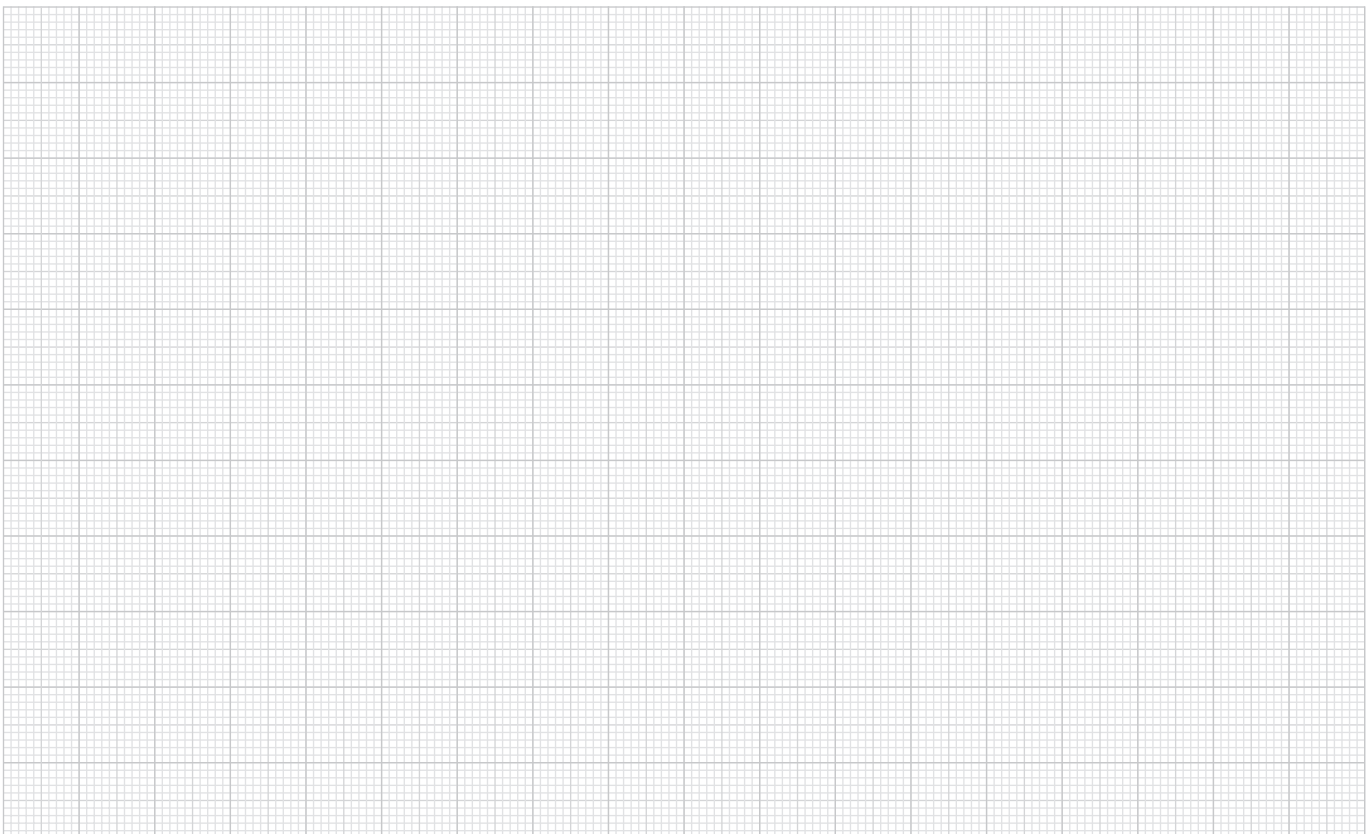

Cam screws

with hexagon washer, for T-slots



Material:

Carbon steel.
Hex washer brass.

Version:

Tempered to 10.9 and black oxidised.

Sample order:

K0027.12

Note:

These fixture clamps can be used directly on machine tables or other tables with T-slots. The grub screw at the rear locks the T-nut in the slot. Thin shims are recommended to prevent marking the bottom of the T-slot.

On request:

Replacement cam screws.

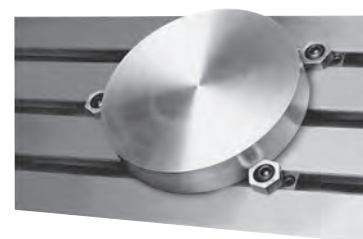
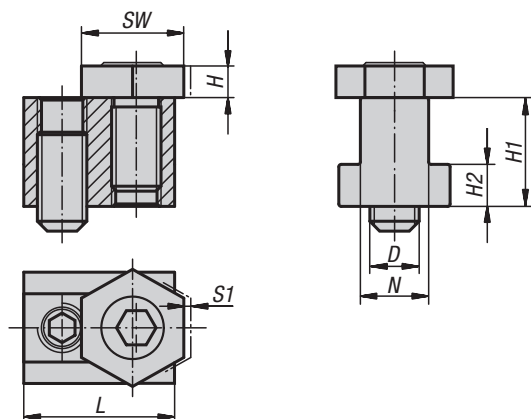

KIPP Cam screws with hexagon washer, for T-slots

Order No.	D	N	H	H1	H2	L	SW	S1 (travel)	Clamping force kN
K0027.08	M6	8	4,8	9,6	4,5	23	16	1	3,4
K0027.10	M6	10	4,8	14	4,5	23	16	1	3,4
K0027.12	M8	12	4,8	15,5	6,5	28	21	1	3,6
K0027.14	M10	14	6,4	22	8,5	30,5	21	1,6	9
K0027.16	M12	16	9,5	22,5	9	30,5	25	2	18
K0027.18	M12	18	9,5	28,5	10	34,5	25	2	18
K0027.20	M16	20	12,7	32	12	39	30	2,5	27
K0027.22	M16	22	12,7	38,2	14	44	30	2,5	27

Cam clamps with riser

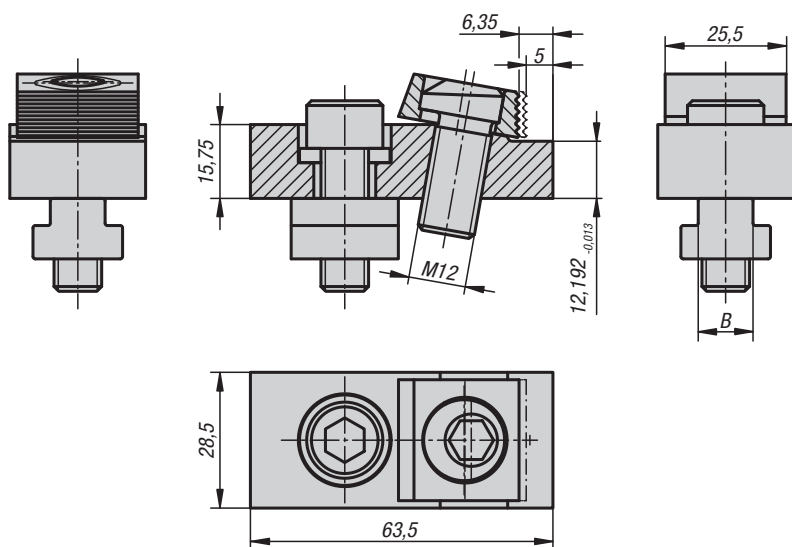

Material:
Steel.

Version:
Body tempered and black oxidised.
Square washer case hardened and brass-plated.

Sample order:
K0028.16

Note:
These cam clamps with riser can be used directly on machine tables. A positive down force is exerted during clamping.

On request:
Replacement cam screws.

KIPP Cam clamps with riser

Order No.	B Slot width	Clamping force kN
K0028.12	12	12
K0028.14	14	12
K0028.16	16	12
K0028.18	18	12

Toe clamps for T-slots



Material:

Steel.

Version:

Body tempered and black oxidised.

Square washer case hardened and brass-plated.

Sample order:

K0029.14

Note:

These toe clamps can be used on machine tables or adapter plates. The positive down force holds the workpiece down on the supporting surface. The square washer can adapt slightly to an angular position i.e. the workpiece does not have to be exactly parallel. The clamping washer has a smooth side for machined surfaces and a serrated side for rough faces.

On request:

Replacement cam screws.

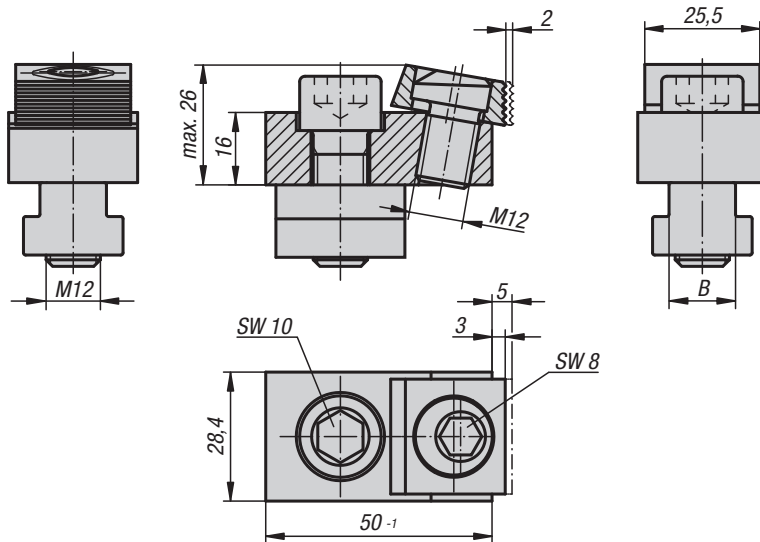

KIPP Toe clamps for T-slots

Order No.	B Slot width	Clamping force kN
K0029.00	without T-nut and fastening screw	18
K0029.14	14	18
K0029.16	16	18
K0029.18	18	18

Chock clamps

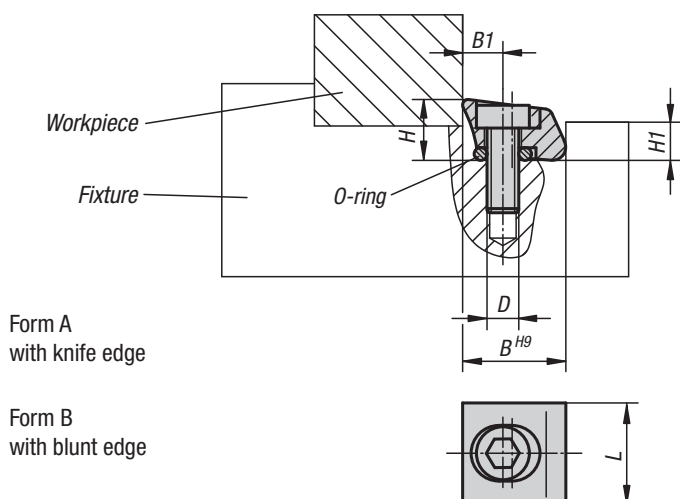

Material:

Clamping element steel or brass.

Version:

Steel hardened.

Sample order:

K0030.113

Note:

Extremely space-saving design.

No protruding edges due to lateral clamping.

Positive down force.

KIPP Chock clamps

Order No.	Form	Material	D	B	B1	H	H1	L	Clamping width	Clamping travel	Clamping force kN	Tightening torque max. Nm
K0030.110	A	steel	M2,5x8	9,5	3,8	6	3,6	9,5	9,5	0,15	2,8	1,8
K0030.113	A	steel	M4x12	12,7	5,1	8	4,8	13	12,7	0,4	6,6	5,6
K0030.119	A	steel	M6x16	19,05	7,6	11,5	7,2	19	19,1	0,6	16	22,5
K0030.210	B	steel	M2,5x8	9,5	3,8	6	3,6	9,5	9,5	0,15	2,8	1,8
K0030.213	B	steel	M4x12	12,7	5,1	8	4,8	13	12,7	0,4	6,6	5,6
K0030.219	B	steel	M6x16	19,05	7,6	11,5	7,2	19	19,1	0,6	16	22,5
K0030.310	B	brass	M2,5x8	9,5	3,8	6	3,6	9,5	9,5	0,15	0,9	0,56
K0030.313	B	brass	M4x12	12,7	5,1	8	4,8	13	12,7	0,4	1,8	2,8
K0030.319	B	brass	M6x16	19,05	7,6	11,5	7,2	19	19,1	0,6	4,2	5,6

Cam clamps

adjustable with riser



K0031.08, K0031.12

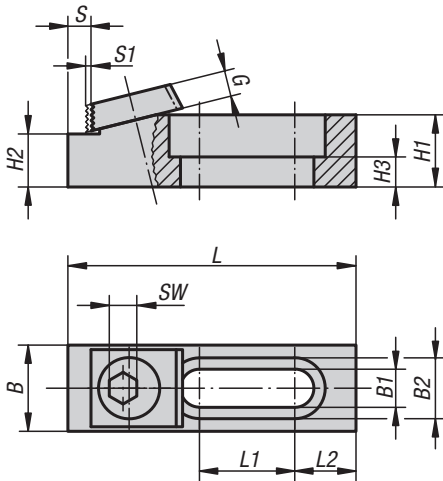

K0031.16

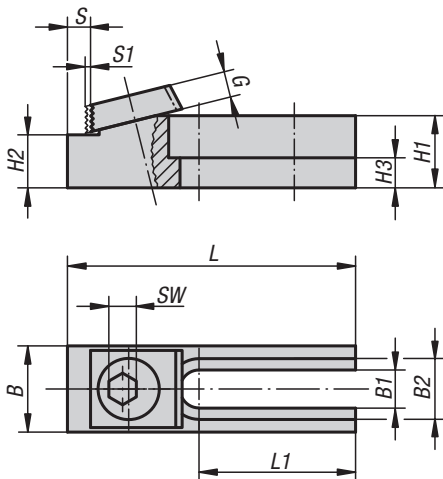

Material:
Steel.

Version:
Body tempered, black oxidised, riser faces ground.
Square washer case hardened and brass-plated.

Sample order:
K0031.12

Note:
Cost-effective custom made clamping fixtures can be produced using the adjustable riser cam clamps together with the matching riser stops.

On request:
Replacement cam screws.

KIPP Cam clamps adjustable with riser

Order No.	suitable fastening screw	L	L1	L2	B	B1	B2	H1	H2	H3	S	S1	G	SW	Oblong hole	Clamping force kN	Tightening torque max. Nm
K0031.08	M8	63,5	21	13,5	19	8,4	13,4	15,9	11,684 -0,013	6,6	6,3	1,2	5,3	7	closed	8,9	28
K0031.12	M12	95,1	42,7	12,7	28,5	13	19,8	15,9	12,192 -0,013	6,9	7,1	2	9,5	8	closed	17,8	88
K0031.16	M16	107	46,3	-	38	17	24,8	41	35,001 ±0,006	21	8,3	2,5	12,7	12	open	26,7	135

Riser stops



K0032.08, K0032.12

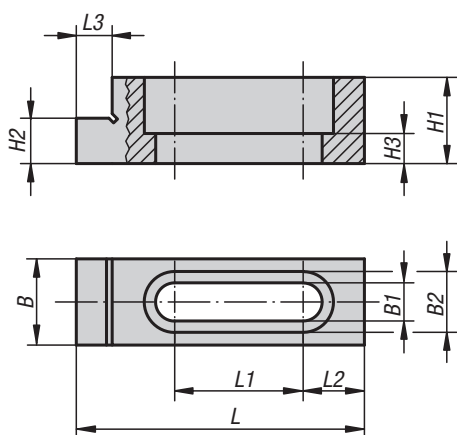

K0032.16

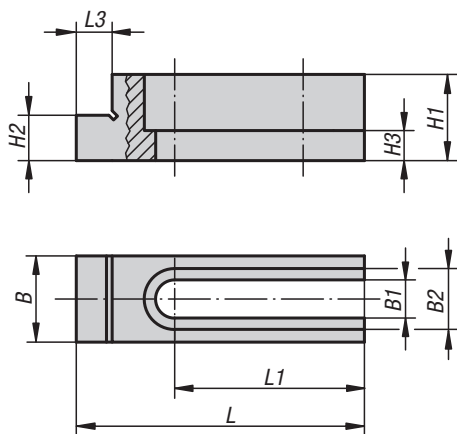

Material:

Steel.

Version:

Tempered, black oxidised.
Riser faces ground.

Sample order:

K0032.12

Note:

Cost-effective custom made clamping fixtures can be produced using the adjustable riser cam clamps together with the matching riser stops.

KIPP Riser stops

Order No.	suitable fastening screw	L	L1	L2	L3	B	B1	B2	H1	H2	H3	Oblong hole
K0032.08	M8	63,5	28,3	13,5	7,9	19	8,4	13,4	19	11,684 -0,013	6,6	closed
K0032.12	M12	95,2	42,7	12,7	7,9	28,5	13,4	19,8	22	12,192 -0,013	6,9	closed
K0032.16	M16	107	46,2	-	9,5	38	17	24,8	50,7	35,001 ±0,006	21,3	open

Side clamps

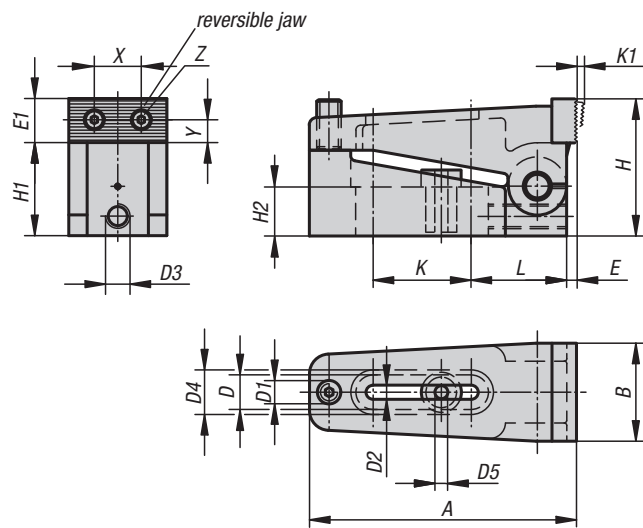

Material:
 Body steel.
 Jaw mild steel.
 Centring bush carbon steel

Version:
 Black oxidised.
 Jaws case-hardened.

Sample order:
 K0033.006

Note:
 The jaws are reversible - smooth side for machined surfaces, serrated side for rough surfaces. A positive down force is also exerted during clamping.

KIPP Side clamps

Order No.	A	B	D	D1	D2	D3	D4	D5	E	E1	H	H1	H2	K	K1	L	X	Y	Z	Clamping force kN
K0033.006	73	25	12,2	M6	7	M6	16	6,5	2,5	11	35	24	12,4	25,5	2,5	27	12	4,5	M3	10
K0033.010	110	39	18,2	M10	11	M10	24	10,5	4	18	56	38	20	40,5	4	39	20,5	8	M5	40
K0033.016	170	58	26,2	M16	17	M10	35	17	7	27	85	60	30	60,5	7	61	32	13	M8	100

Side clamps

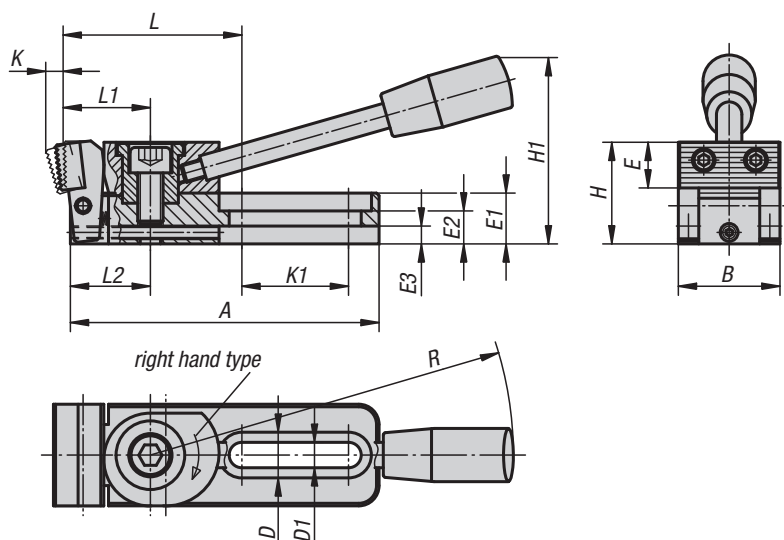

Material:
Steel.

Version:
Case-hardened and black oxidised.

Sample order:
K0034.006010

Note:
This is a quick-action side clamp where workpieces are clamped by rotating a cam wheel which exerts pressure on the swivel jaw, simultaneously producing a positive down force. Using the stop screw and centring bush (see diagram), the side clamp can be mounted and positioned on a modular grid system.

Form A
steel jaw
serrated

Form B
jaw with 2 round
carbide inserts

Form C
jaw with 2 round
carbide inserts
and central prism

Form D
POM jaw
serrated

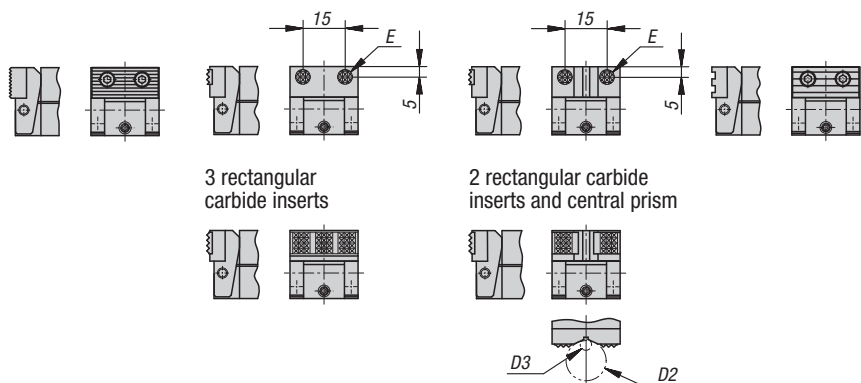

The versions K0034.006010, K0034.006015, K0034.006030 and K0034.006035 have 2 round carbide inserts.

Clamping force:
K0034.006... = 3800 N
K0034.010... = 7200 N

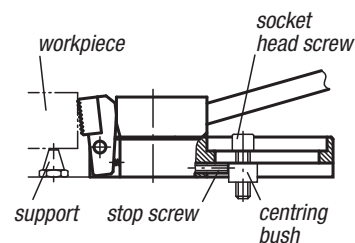

KIPP Side clamps

Order No.	Form	Version	A	B	D	D1	D2 max.	D3 min.	E	E1	E2	E3	H	H1	K	K1	L	L1	L2	R	Clamping force kN
K0034.006005	A	right-hand type	78	25	12	6,2	-	-	11	12	8	4	25	45	4	26	46,5	22	20	110	3,8
K0034.010005	A	right-hand type	121,5	40	18	10,2	-	-	18	20	13	7	40	74	6	42	71	35	31,5	143	7,2
K0034.006025	A	left-hand type	78	25	12	6,2	-	-	11	12	8	4	25	45	4	26	46,5	22	20	110	3,8
K0034.010025	A	left-hand type	121,5	40	18	10,2	-	-	18	20	13	7	40	74	6	42	71	35	31,5	143	7,2
K0034.006010	B	right-hand type	78	25	12	6,2	-	-	∅ 8	12	8	4	24	45	3,5	26	46,5	22	20	110	3,8
K0034.010010	B	right-hand type	121,5	40	18	10,2	-	-	12,7	20	13	7	39	74	5,5	42	73	35	31,5	143	7,2
K0034.006030	B	left-hand type	78	25	12	6,2	-	-	∅ 8	12	8	4	24	45	3,5	26	46,5	22	20	110	3,8
K0034.010030	B	left-hand type	121,5	40	18	10,2	-	-	12,7	20	13	7	39	74	5,5	42	73	35	31,5	143	7,2
K0034.006015	C	right-hand type	78	25	12	6,2	9,5	2,5	∅ 8	12	8	4	24	45	3,5	26	46,5	22	20	110	3,8
K0034.010015	C	right-hand type	121,5	40	18	10,2	27	4,5	12,7	20	13	7	39	74	5,5	42	73	35	31,5	143	7,2
K0034.006035	C	left-hand type	78	25	12	6,2	9,5	2,5	∅ 8	12	8	4	24	45	3,5	26	46,5	22	20	110	3,8
K0034.010035	C	left-hand type	121,5	40	18	10,2	27	4,5	12,7	20	13	7	39	74	5,5	42	73	35	31,5	143	7,2
K0034.006020	D	right-hand type	78	25	12	6,2	-	-	11	12	8	4	25	45	4,5	26	46,5	22	20	110	3,8
K0034.010020	D	right-hand type	121,5	40	18	10,2	-	-	18	20	13	7	40	74	7	42	70,5	35	31,5	143	7,2
K0034.006040	D	left-hand type	78	25	12	6,2	-	-	11	12	8	4	25	45	4,5	26	46,5	22	20	110	3,8
K0034.010040	D	left-hand type	121,5	40	18	10,2	-	-	18	20	13	7	40	74	7	42	70,5	35	31,5	143	7,2

Side clamps

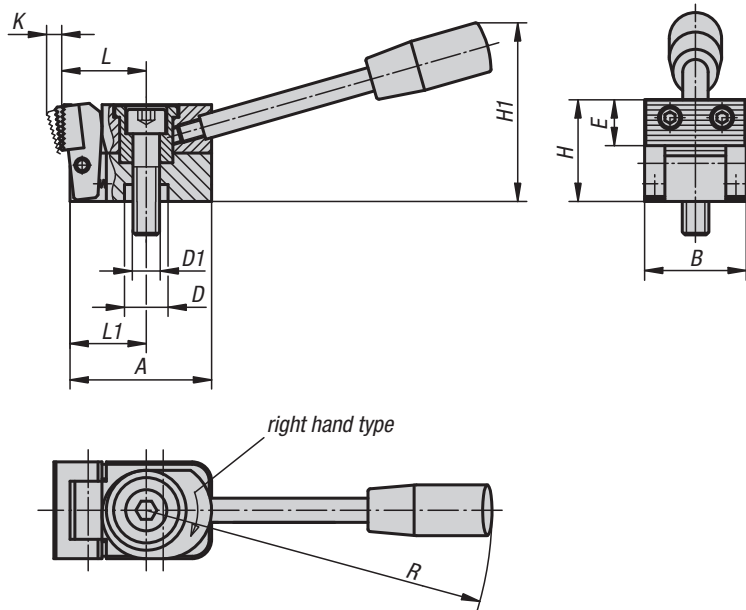

Material:
Steel.

Version:
Case-hardened and black oxidised.

Sample order:
K0035.006005

Note:
This is a quick-action side clamp where workpieces are clamped by rotating a cam wheel which exerts pressure on the swivel jaw, simultaneously producing a positive down force.
Using the centring bush (see diagram), the side clamp can be mounted and positioned on a modular grid system.

Form A
steel jaw
serrated

Form B
jaw with 2 round
carbide inserts

Form C
jaw with 2 round
carbide inserts
and central prism

Form D
POM jaw
serrated

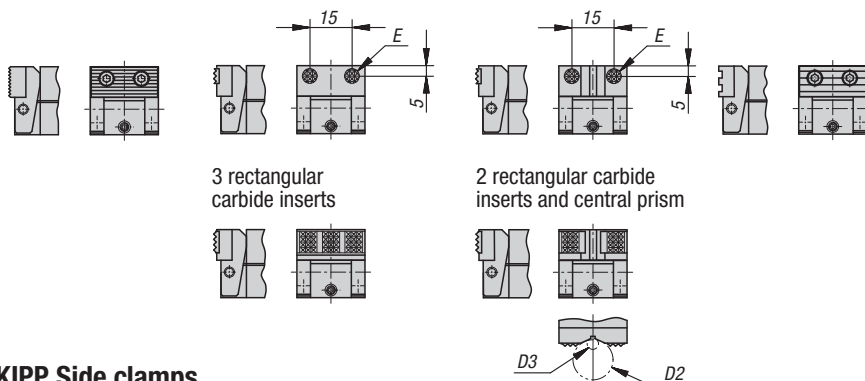

The versions K0035.006010, K0035.006015, K0035.006030 and K0035.006035 have 2 round carbide inserts.

Clamping force:
K0035.006... = 3800 N
K0035.010... = 7200 N

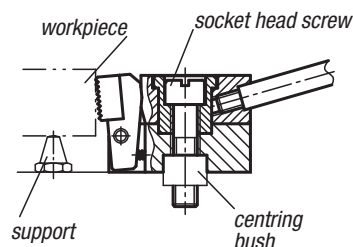

KIPP Side clamps

Order No.	Form	Version	A	B	D	D1	D2 max.	D3 min.	E	H	H1	K	L	L1	R	Clamping force kN
K0035.006005	A	right-hand type	38,5	25	12	M6	-	-	11	25	45	4	22	20	110	3,8
K0035.010005	A	right-hand type	58,5	40	18	M10	-	-	18	40	74	6	35	31,5	143	7,2
K0035.006025	A	left-hand type	38,5	25	12	M6	-	-	11	25	45	4	22	20	110	3,8
K0035.010025	A	left-hand type	58,5	40	18	M10	-	-	18	40	74	6	35	31,5	143	7,2
K0035.006010	B	right-hand type	38,5	25	12	M6	-	-	∅ 8	24	45	3,5	22	20	110	3,8
K0035.010010	B	right-hand type	58,5	40	18	M10	-	-	12,7	39	74	5,5	37	31,5	143	7,2
K0035.006030	B	left-hand type	38,5	25	12	M6	-	-	∅ 8	24	45	3,5	22	20	110	3,8
K0035.010030	B	left-hand type	58,5	40	18	M10	-	-	12,7	39	74	5,5	37	31,5	143	7,2
K0035.006015	C	right-hand type	38,5	25	12	M6	9,5	2,5	∅ 8	24	45	3,5	22	20	110	3,8
K0035.010015	C	right-hand type	58,5	40	18	M10	27	4,5	12,7	39	74	5,5	37	31,5	143	7,2
K0035.006035	C	left-hand type	38,5	25	12	M6	9,5	2,5	∅ 8	24	45	3,5	22	20	110	3,8
K0035.010035	C	left-hand type	58,5	40	18	M10	27	4,5	12,7	39	74	5,5	37	31,5	143	7,2
K0035.006020	D	right-hand type	38,5	25	12	M6	-	-	11	25	45	4,5	22	20	110	3,8
K0035.010020	D	right-hand type	58,5	40	18	M10	-	-	18	40	74	7	34,5	31,5	143	7,2
K0035.006040	D	left-hand type	38,5	25	12	M6	-	-	11	25	45	4,5	22	20	110	3,8
K0035.010040	D	left-hand type	58,5	40	18	M10	-	-	18	40	74	7	34,5	31,5	143	7,2

Toe clamps compact



Material:
Steel.

Version:
Body tempered and black oxidised.
Square washer case-hardened and brass-plated.

Sample order:
K0036.10

Note:
This cam action compact toe clamp requires very little space to produce multi-fixture clamping. Workpieces can be clamped in series by using the back side of a clamp as a stop for the next row. Mount preferably in slots with $B + 0.05$ mm. The height of the clamp can be adjusted by altering the slot depth.

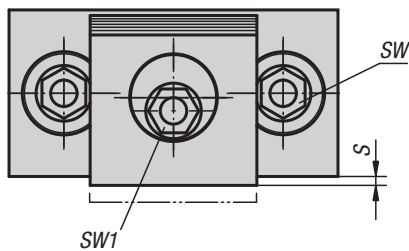
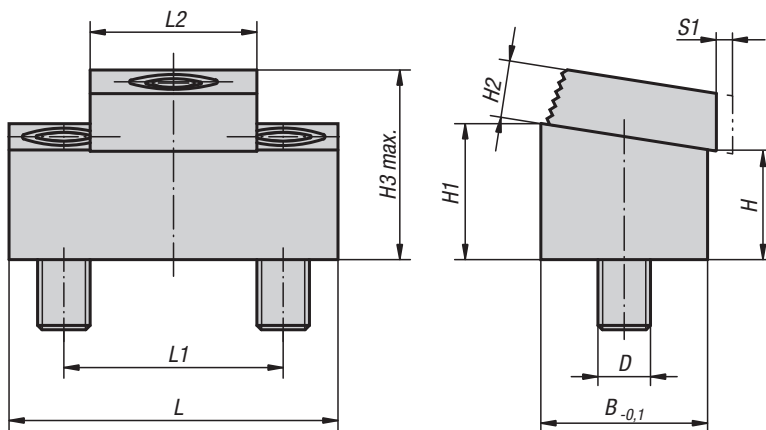

Example of series clamping using compact toe clamps

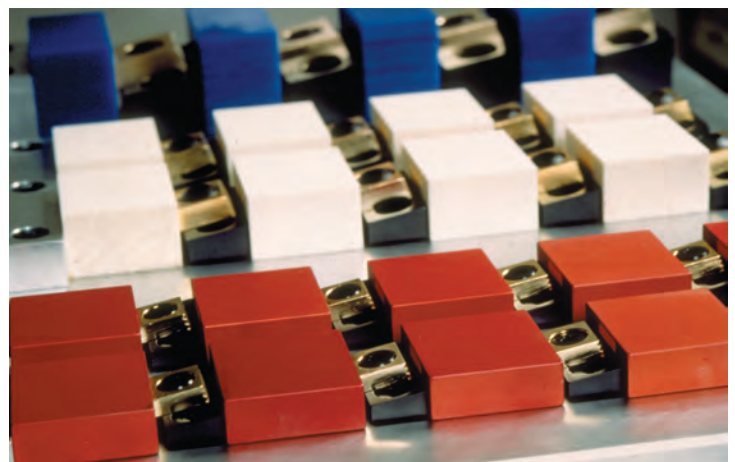

KIPP Toe clamps compact

Order No.	L	L1	L2	B	H	H1	H2	H3 max.	S	D	S1 (travel)	SW	SW1	Clamping force kN	Tightening torque max. Nm
K0036.08	43,2	25,4	19	19	12,7	15,7	6,4	21,4	1,5	M8	1,6	5	7	8,9	28
K0036.10	54	33,5	25,4	25,4	11,4	15,4	9,7	24,5	1,8	M10	2	7	8	17,8	88
K0036.12	75	50,8	38	38,1	25,5	31,5	13	43	2,05	M12	2,5	10	12	26,7	135

Wedge clamps

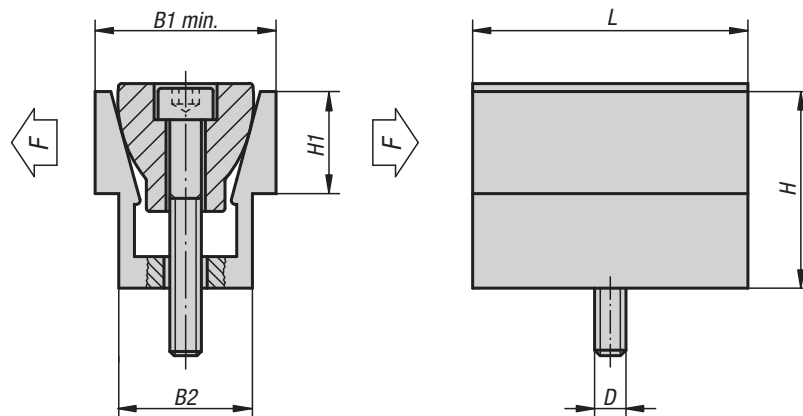
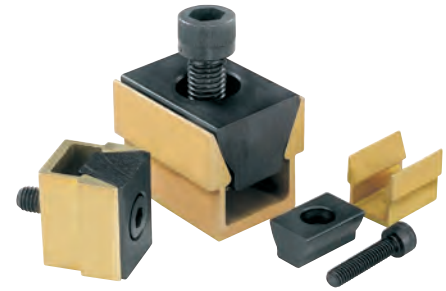

Material:
Channel aluminium profile.
Wedge hardened steel.

Version:
Channel anodized.
Wedge black oxidised.

Sample order:
K0037.08

Note:
Two workpieces can be held simultaneously with the wedge clamp. They are ideal for clamping round or rectangular pieces. The compact design allows space-saving series clamping.

In clamped position
dimension B1 max. given in
the table should be achieved.

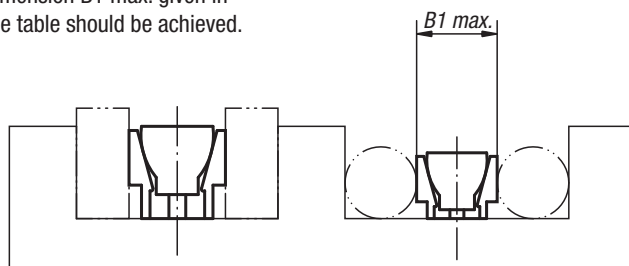

KIPP Wedge clamps

Order No.	D	L	B1 min. - max.	B2	H	H1	F kN	Tightening torque max. Nm
K0037.04	M4	15,9	12,3 - 13,1	10,4	12,7	5,6	2,2	3,4
K0037.06	M6	23,8	18,6 - 19,9	16,1	19	9,5	6,7	14,3
K0037.08	M8	31,7	24,8 - 26,6	20,8	25,4	12,7	8,9	14,5
K0037.12	M12	47,6	37,3 - 39,7	30,8	38,1	19	15,6	38,4
K0037.16	M16	63,5	49,7 - 52,8	41,2	50,8	25,4	26,7	74,6

Wedge clamps

machinable



The locking plate is only used for machining the form, not for clamping the workpiece

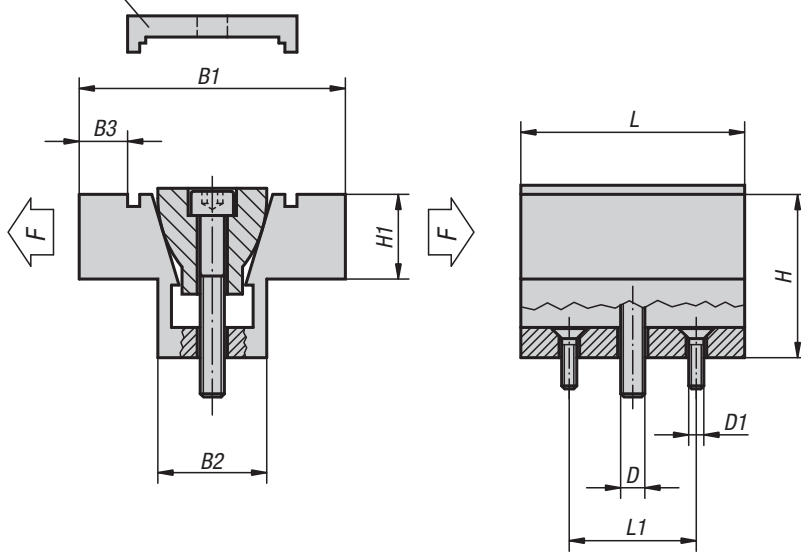

Material:

Channel aluminium profile.
Wedge hardened steel.

Version:

Channel anodized.
Wedge black oxidised.

Sample order:

K0038.08

Note:

Two workpieces can be held simultaneously with the wedge clamp. The jaws have extra material allowing them to be machined to conform to the shape of the workpiece. The compact design allows space-saving series clamping.

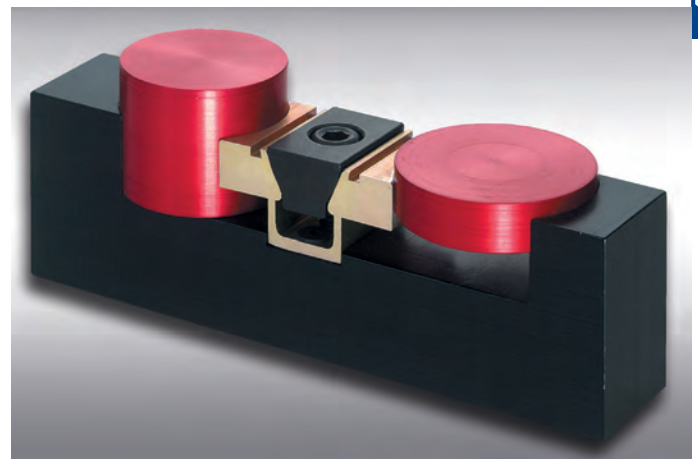

KIPP Wedge clamps machinable

Order No.	D	D1	L	L1	B1 min. - max.	B2	B3	H	H1	F kN	Tightening torque max. Nm
K0038.04	M4	M2	15,7	10,16	28,6 - 29,1	10,6	4,6	12,7	6,3	2,2	3,4
K0038.06	M6	M4	23,9	15,9	38,1 - 39	16,1	6,6	19,1	9,4	6,7	14,3
K0038.08	M8	M4	31,8	20,6	50,8 - 52	20,8	9,9	25,4	12,7	8,9	14,5
K0038.12	M12	M5	47,5	30,5	76,2 - 78	30,9	15,7	38,1	19	15,6	38,4
K0038.16	M16	M6	63,5	41,28	101,6 - 103,9	41,3	20,3	50,8	25,4	26,7	74,6

Wedge clamps

jaw face smooth or serrated



Material:

Wedge and jaw segments carbon steel.

Version:

Wedge and jaw segments hardened, black.

Sample order:

K0039.2208

Note:

The functioning principle make the wedge clamps ideal for series clamping. The wedge form can exert high clamping forces.

These wedge clamps can be mounted in grid holes or T-slots. Tightening the socket screw moves the wedge down and the jaws out pressing the workpieces against the fixtures fixed stops.

The wedge has a slightly elongated hole allowing for movement to compensate for tolerances.

Spread width:

M8 = ±0.5 mm

M10 = ±1.0 mm

M12 = ±1.0 mm

M16 = ±1.5 mm

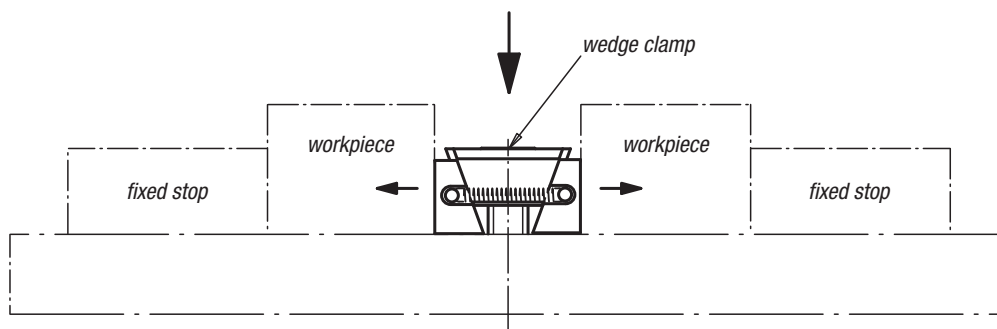
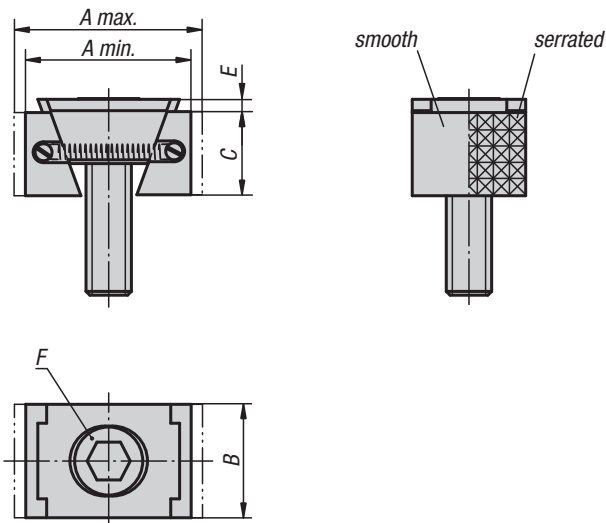

KIPP Wedge clamps, narrow version

Order No. jaw face smooth	Order No. jaw face serrated	A min.	A max.	B	C	E	F Socket head screw DIN 6912	Clamping force kN	Tightening torque Nm
K0039.1108	K0039.2108	30,5	33,5	24	15	2	M8x25	15	25
K0039.1110	K0039.2110	32	37	28	19	3,5	M10x25	20	49
K0039.1112	K0039.2112	44	49,5	30	22	3,5	M12x40	30	85
K0039.1116	K0039.2116	55	62	40	29	4	M16x60	50	210

KIPP Wedge clamps, wide version

Order No. jaw face smooth	Order No. jaw face serrated	A min.	A max.	B	C	E	F Socket head screw DIN 6912	Clamping force kN	Tightening torque Nm
K0039.1208	K0039.2208	30,5	33,5	30	15	2	M8x25	15	25
K0039.1210	K0039.2210	32	37	38	19	3,5	M10x25	20	49
K0039.1212	K0039.2212	44	49,5	48	22	3,5	M12x40	30	85
K0039.1216	K0039.2216	55	62	48	29	4	M16x60	50	210

Wedge clamps

machinable

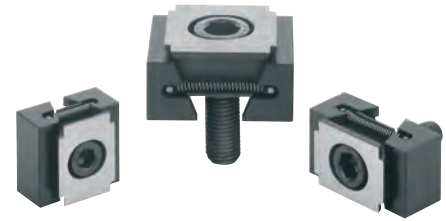

Material:

Wedge and jaw segments carbon steel.

Version:

Wedge and jaw segments tempered, black.

Sample order:

K0649.3110

Note:

These wedge clamps have extra long jaws. This extra material allows the jaws to be machined to suit the form of the workpiece.

The functioning principle makes the wedge clamps ideal for series clamping. The wedge form can exert high clamping forces.

These wedge clamps can be mounted in grid holes or T-slots. Tightening the socket screw moves the wedge down and the jaws out, pressing the workpieces against the fixtures' fixed stops.

The wedge has a slightly elongated hole allowing for movement to compensate for tolerances.

Spread width:

M8 = ±0.5 mm

M10 = ±1.0 mm

M12 = ±1.0 mm

M16 = ±1.5 mm

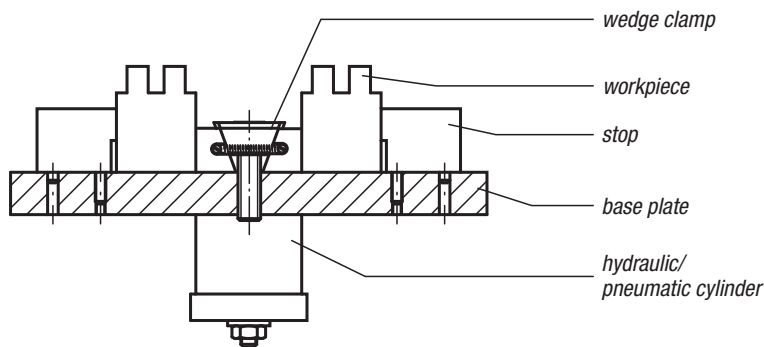
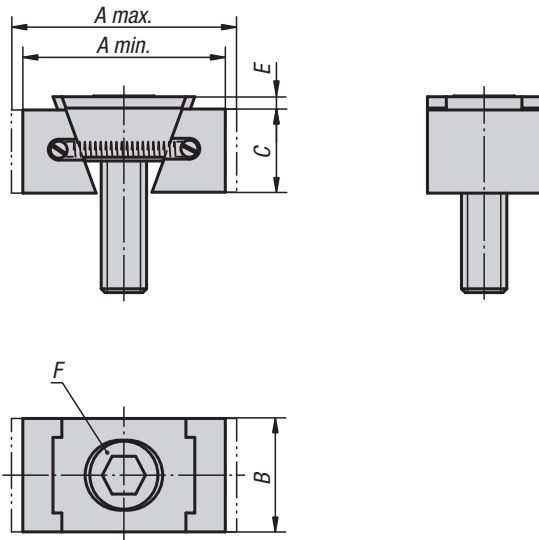

KIPP Wedge clamps, machinable

Order No.	Version	A min.	A max.	B	C	E	F Socket head screw DIN 6912	Clamping force kN	Tightening torque Nm
K0649.3108	narrow	36,5	39,5	24	15	2	M8x25	11	19
K0649.3110	narrow	42	47	28	19	3,5	M10x25	15	37
K0649.3112	narrow	54	59,5	30	22	3,5	M12x40	23	65
K0649.3116	narrow	65	72	40	29	4	M16x60	38	160
K0649.3208	wide	36,5	39,5	30	15	2	M8x25	11	19
K0649.3210	wide	42	47	38	19	3,5	M10x25	15	37
K0649.3212	wide	54	59,5	48	22	3,5	M12x40	23	65
K0649.3216	wide	65	72	48	29	4	M16x60	38	160

Wedge clamps

jaw faces serrated



Material:

Body and clamping segments tool steel.

Version:

Body hardened.

Jaw segments hardened (49-51 HRC) black oxidised.

Wedge faces ground.

Sample order:

K0040.1618

Note:

The compact design makes these wedge clamps ideal for horizontal and vertical series clamping. The hardened and ground wedge faces can exert high clamping forces. These wedge clamps can be mounted in grid holes or T-slots. Tightening the DIN 912 socket screw moves the wedge down and the jaws out pressing the workpieces against the fixtures fixed stops.

The jaws of version K0040.08 and K0040.0810 are not serrated.

The wedge has a slightly elongated hole allowing for movement.

Spread width:

K0040.08 = ±0.5 mm

K0040.12 = ±1.0 mm

K0040.16 = ±1.5 mm.

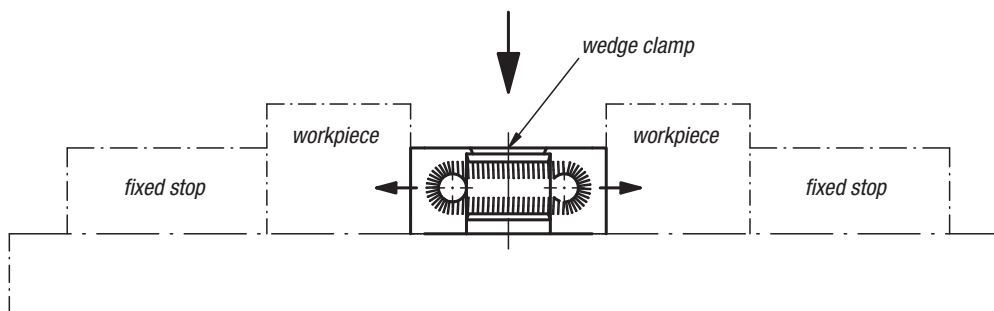
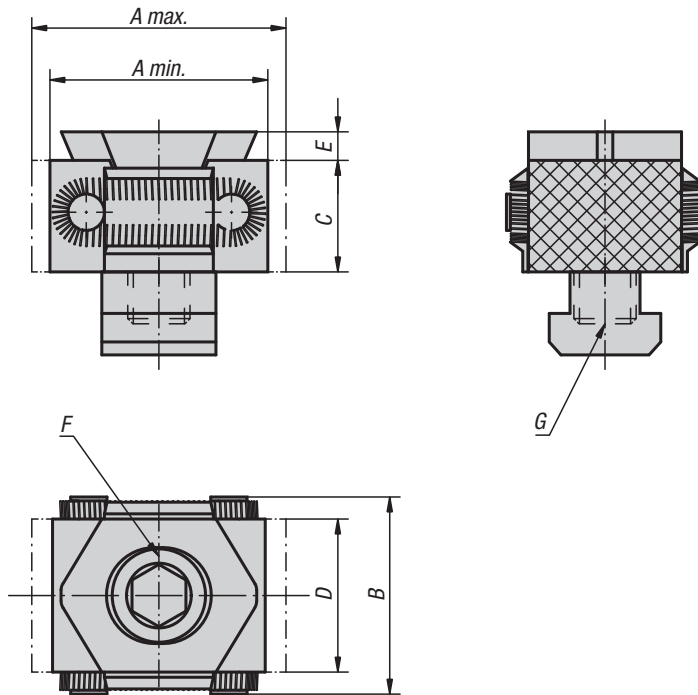

KIPP Wedge clamps, jaw faces serrated

Order No.	A min.	A max.	B	C	D	E	F	G	Clamping force kN	Tightening torque Nm
K0040.08	27	31	29	15	21	2,5	M8x25	for threaded hole	15	25
K0040.0810	27	31	29	15	21	2,5	M8x25	for T-slot 10	15	25
K0040.12	42	49	41	22	30	4	M12x40	for threaded hole	30	85
K0040.1214	42	49	41	22	30	4	M12x30	for T-slot 14	30	85
K0040.16	57	66	56	29	42	5	M16x60	for threaded hole	50	210
K0040.1618	57	66	56	29	42	5	M16x50	for T-slot 18	50	210

Wedge clamps

machinable



Material:
 Body tool steel.
 Jaw segments tool steel (30 HRC).

Version:
 Body hardened.
 Jaw segments black oxidised.
 Wedge faces ground.

Sample order:
 K0041.12

Note:
 These wedge clamps have a machining allowance per jaw of 3 mm for version K0041.08 and 5 mm for versions K0041.12 and K0041.16. This extra material allows the jaws to be machined to suit the form of the workpiece.

The jaws version K0041.08 and K0041.0810 are not serrated.

Spread width:
 K0041.08 = ±0.5 mm
 K0041.12 = ±1.0 mm
 K0041.16 = ±1.5 mm

On request:
 Pre-formed jaw segments or other hardness grades.

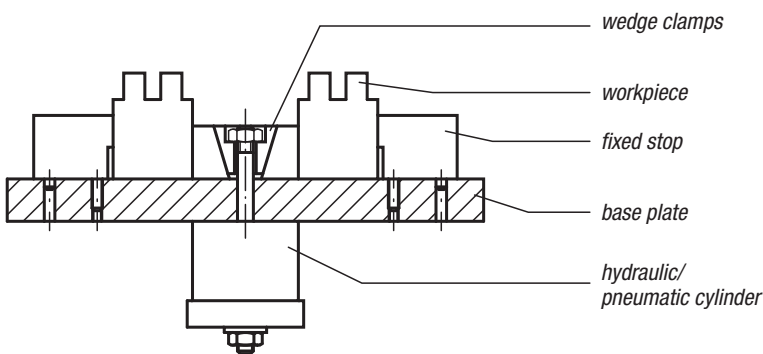
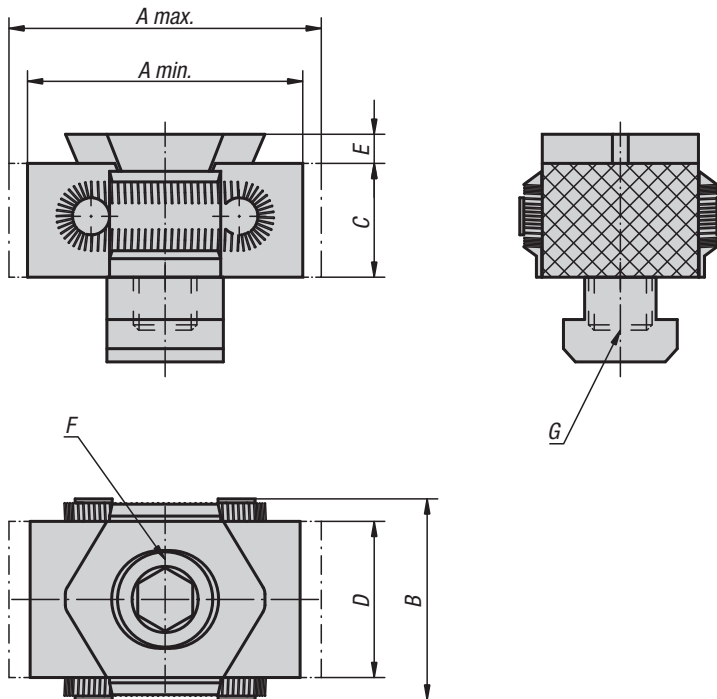

KIPP Wedge clamps machinable

Order No.	A min.	A max.	B	C	D	E	F	G	Clamping force kN	Tightening torque Nm
K0041.08	33	37	29	15	21	2,5	M8x25	for threaded hole	15	25
K0041.0810	33	37	29	15	21	2,5	M8x25	for T-slot 10	15	25
K0041.12	52	59	41	22	30	4	M12x40	for threaded hole	30	85
K0041.1214	52	59	41	22	30	4	M12x30	for T-slot 14	30	85
K0041.16	67	76	56	29	42	5	M16x60	for threaded hole	50	210
K0041.1618	67	76	56	29	42	5	M16x50	for T-slot 18	50	210

Wedge clamps double wedge

jaw faces serrated



Material:

Body and jaw segments tool steel.

Version:

Body hardened.

Jaw segments hardened (49-51 HRC) and black oxidised.

Wedge faces ground.

Sample order:

K0042.1214

Note:

The compact design makes these double wedge clamps ideal for horizontal and vertical series clamping. The hardened and ground wedge faces can exert high clamping forces.

These wedge clamps can be mounted in grid holes or T-slots. Tightening the DIN 912 socket screw pulls the wedges together and the jaws out pressing the workpieces against the fixtures fixed stops.

The double wedges create a positive down force.

Spread width:

K0042.12 = ±1.0 mm

K0042.16 = ±1.5 mm

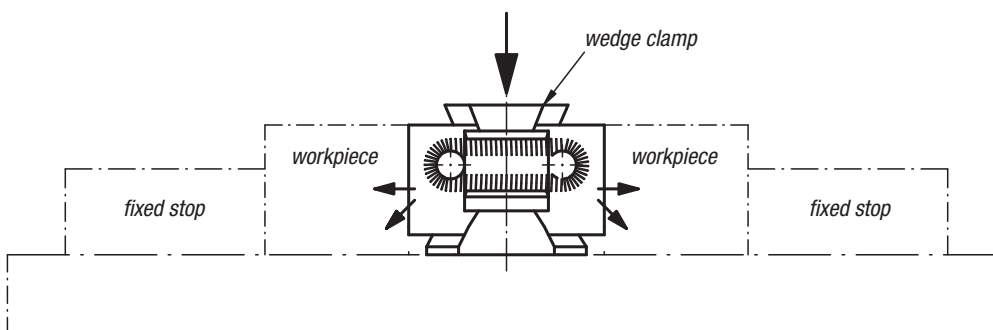
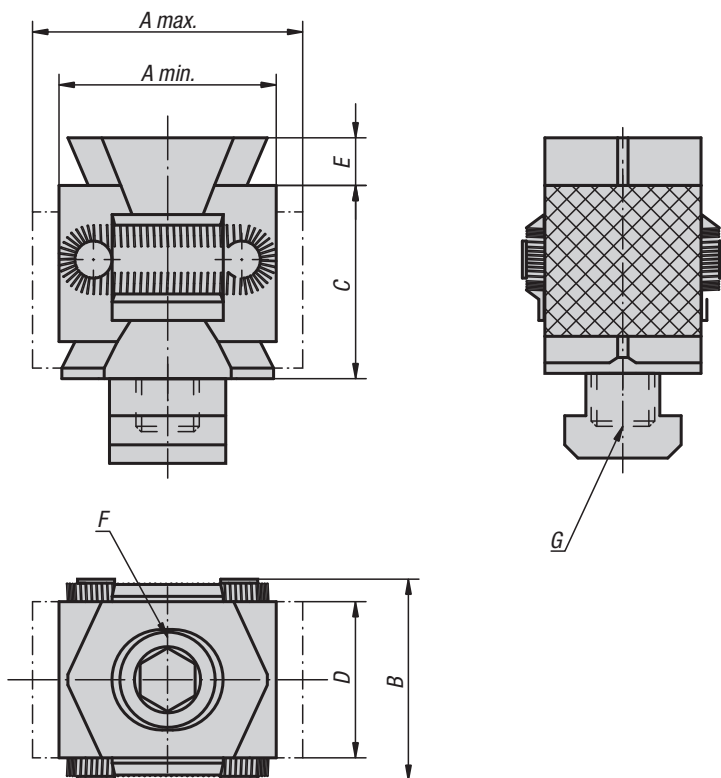

KIPP Wedge clamps double wedge, jaw faces serrated

Order No.	A min.	A max.	B	C	D	E	F Socket head screw DIN 912	G	Clamping force kN	Tightening torque Nm
K0042.12	42	49	41	36	30	5	M12x60	for threaded hole	40	85
K0042.1214	42	49	41	36	30	5	M12x50	for T-slot 14	40	85
K0042.16	57	67	56	50	42	5	M16x80	for threaded hole	60	210
K0042.1618	57	67	56	50	42	5	M16x70	for T-slot 18	60	210

Mandrel collets

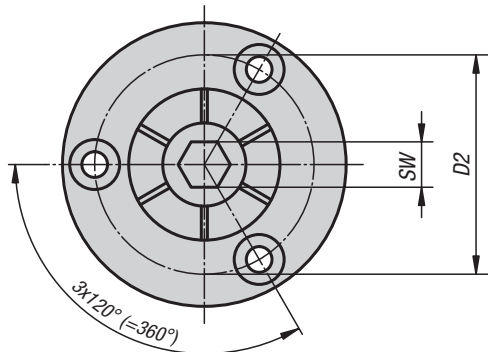
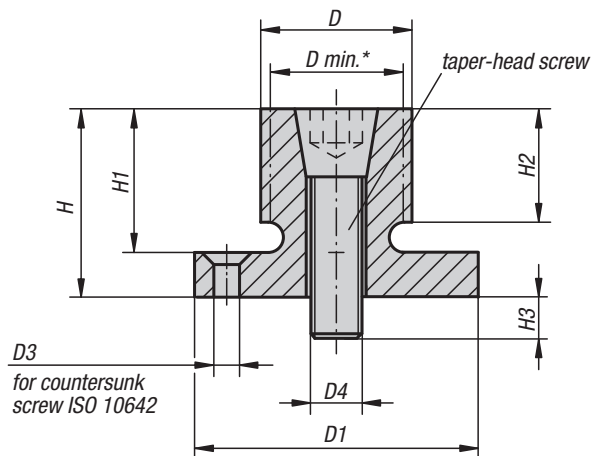

K0357.1630175

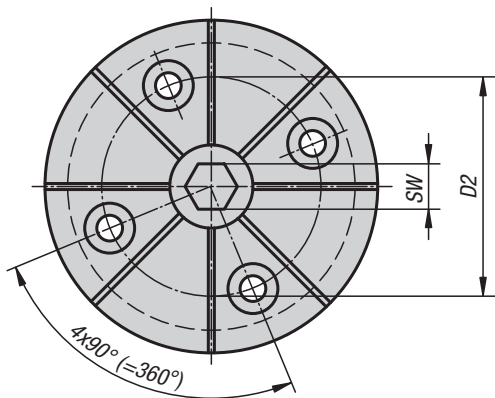

Material:
Mandrel mild steel.
Taper-head screw low-carbon steel

Version:
Mandrel black oxidised.
Taper-head screw case-hardened.

Sample order:
K0357.081420

Note:
The mandrel collet is ideal for finish machining turned parts. The diameter D can be turned or milled to suit the workpiece ID.
Low design - no interfering clamp straps.
Tightened using a hex socket wrench or hydraulics.

* D min. = smallest diameter to which „D“ may be turned or milled.

Assembly:
Expand the mandrel approx. 0.1 mm over the relaxed diameter. Turn or mill the mandrel to suit the internal diameter of the workpiece. The base flange can be centred in a pocket or using dowel pins.

KIPP Mandrel collets

Order No.	D	D min.	D1	D2	D3 for screw	D4 Tapered-head bolt	H	H1	H2	H3	SW Tapered-head bolt	Tightening torque max. Nm	Clamping force max. kN
K0357.020407	7,4	4,1	20 h9	13,7	M2	M2	10,7	7,6	6,1	4,1	1,5	0,7	1,1
K0357.040812	12,4	7,2	29,72 h9	21	M3	M4	21,8	16	15	8	3	5	4,2
K0357.061214	14,2	12,2	31,5 h9	23,1	M3	M6	24,9	19	15	12	5	17	8,5
K0357.081420	20	13,5	37,5 h9	29	M3	M8	24,9	19	15	14	6	34	11,1
K0357.062027	27	18	50 h9	39,4	M4	M10	28,6	22,2	17,5	17	8	60	20
K0357.102535	35,3	23	56 h9	45,5	M4	M12	31,8	25,4	20,6	21	10	150	26,3
K0357.123442	42	30	69,5 h8	55,9	M5	M16	39,6	31,8	27	22	14	280	44,5
K0357.123452	51,5	23	75,5 h9	63,9	M5	M16	39,6	31,8	27	22	14	280	44,5
K0357.163077	77,7	23	107,5 h9	92,5	M6	M16	45,5	37,6	32,3	20	14	280	44,5
K0357.1630103	103	23	132,9 h9	118	M6	M16	45,5	37,6	32,3	20	14	280	44,5
K0357.1630175	175	23	132,9 h9	118	M6	M16	45,5	37,6	32,3	20	14	280	44,5

Mandrel collets

with side lock



Form A
for machining centres,
drilling and milling machines

Form B
with shaft for holding
in lathe chucks

Material:
Mandrel mild steel.
Clamping screw carbon steel.

Version:
Mandrel black oxidised.
Clamping screw tempered to 10.9,
hardened and PTFE coated.

Sample order:
K0643.118029

Note:
The side lock make these mandrel collets ideal for
finish machining parts with blind internal diameters.
The diameter D can be turned or milled to suit the
workpiece ID.

Manual tightening with hexagon socket wrench.

* D min. = smallest diameter to which „D“ may be
turned or milled.

Assembly:
Expand the mandrel approx. 0.1 mm over the relaxed
diameter. Turn or mill the mandrel to suit the internal
diameter of the workpiece. A locking ring is included
for machining.

The shank or flange is centred in a reamed hole or
pocket.

Form A is supplied with 6 fastening screws.

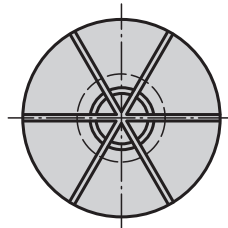
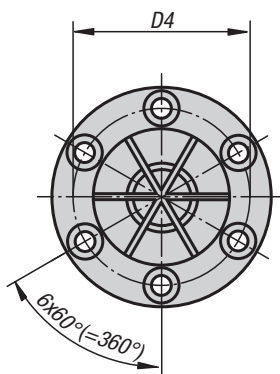
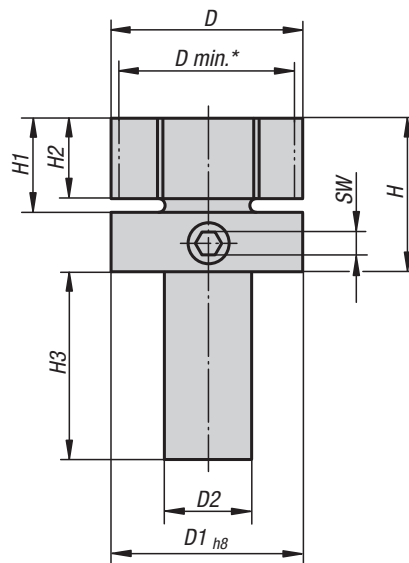
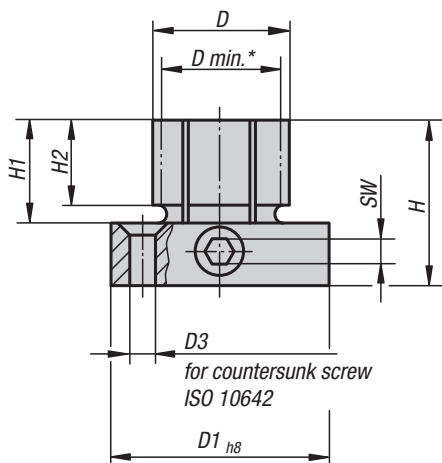

KIPP Mandrel collets with side lock

Order No.	Form	D	D min.	D1	D2	D3 for screw	D4	H	H1	H2	H3	SW	Tightening torque max. Nm	Clamping force max. kN
K0643.118029	A	28,7	17,8	50	-	M4	39,4	41,3	22,4	17,5	-	6	66	20
K0643.218053	B	53,3	18	53,3	25	-	-	44,4	25,4	21	45	6	66	20

Shaft clamping units

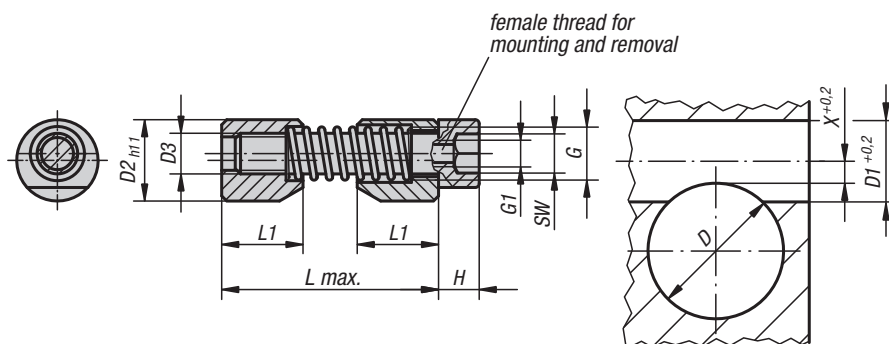

Material:
 Jaws steel.
 Spring 1.4310.
 Screw grade 8.8.

Version:
 Jaws black oxidised.
 Screw blue galvanised.

Sample order:
 K0375.04

Note:
 These shaft clamping units are the simple alternative to conventional shaft clamping (slot and grub screw). The units are suitable for various materials (metal, plastic, wood etc).
 To loosen a jammed clamp simply hit it axially or extract it using a screw in the jaw end or screw head.

Application:

axial and radial clamping

clamping torque M_x

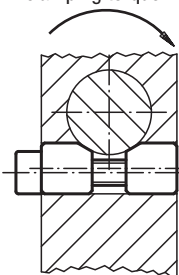

adjusting and clamping

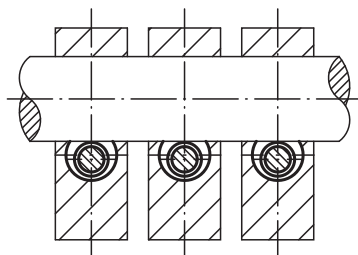

spacer rings *K*
 for deep holes

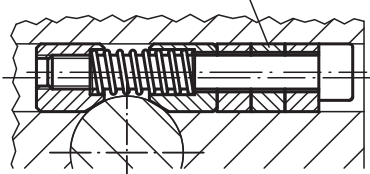

Shafts situated away from the outer edge can also be clamped using spacer rings and longer screws (without mounting thread).

assembly tool



Special hex key with a threaded pin. The pin is screwed into the hole G_1 in the head of the cap screw to aid in positioning or removing the clamping unit.

Mounting instructions:

Insert clamping unit

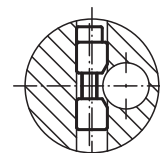

Insert shaft or tube

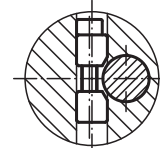

Clamp shaft or tube

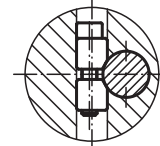

KIPP Shaft clamping units

Order No.	D	D1	D2	D3	L max.	L1	X	G	G1	H	K	SW	Mx Nm	Order No. assembly tool
K0375.04	6-10	8	8	M4	27	8	2,8	M5	M2,5	4	10	3	max. 20	K0375.904
K0375.05	10-15	10	10	M5	33	10	3,3	M6	M3	5	10	4	max. 45	K0375.905
K0375.06	15-20	12	12	M6	39	12	3,5	M7	M4	6	10	5	max. 100	K0375.906
K0375.08	20-30	16	16	M8	46	16	4	M10	M5	8	10	6	max. 170	K0375.908
K0375.10	30-40	20	20	M10	53	20	4,8	M12	M6	10	15	8	max. 290	K0375.910
K0375.12	40-60	25	25	M12	70	25	5,6	M14	M8	12	15	10	max. 450	K0375.912
K0375.16	60-125	30	30	M16	81	30	7,9	M18	M10	16	15	14	max. 650	K0375.916

Centring clamps

with ball or hexagon segments

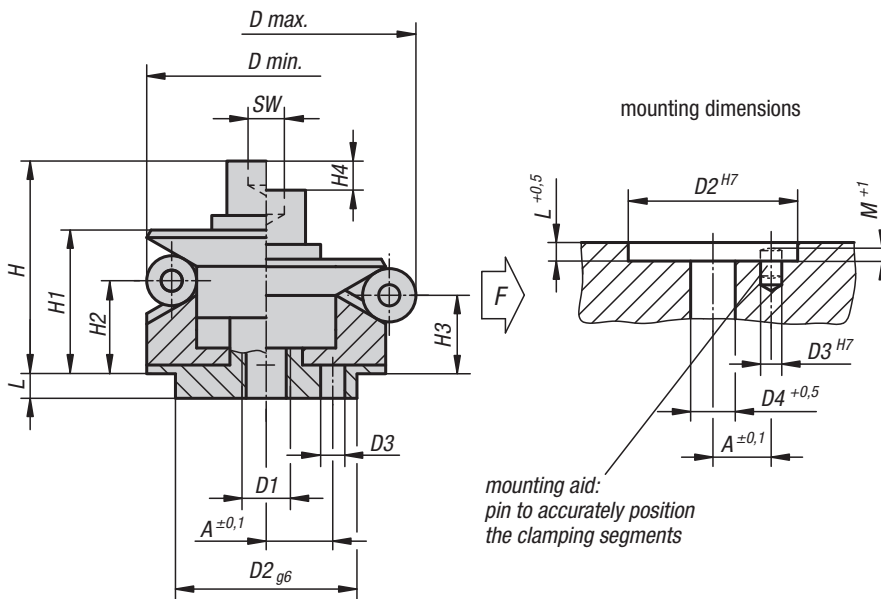

Material:

Body 1.2842.
Ball and hex segments 1.4112.
Tension spring 1.4310.

Version:

Body hardened and black oxidised.
Ball and hex segments hardened and ground.

Sample order:

K0358.101203

Note:

Form A: With balls for holes where light marking is acceptable.
Form B: With hexagons for sensitive hole surfaces.

Application:

To position and centre existing bores on the machining surface.

Advantages:

- Precise self-centring.
- Distortion free clamping.
- Large spread range.
- Low overall height.

Technical data:

Repetitive accuracy ± 0.025
Concentric accuracy ± 0.05

Form A
spherical, point contact

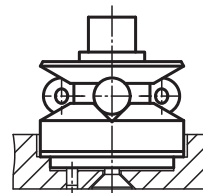
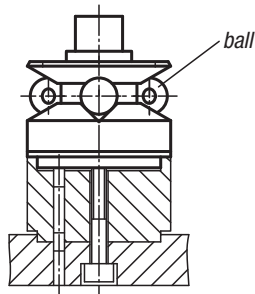

Form B
flat, non-marking

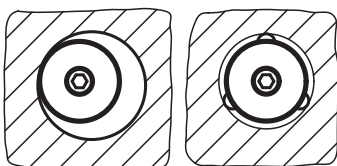
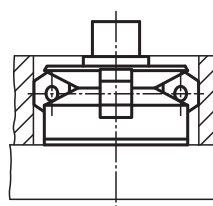
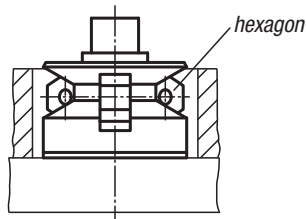

Centring clamps

with ball or hexagon segments

KIPP Centring clamps with ball segments

Order No.	Form	A	D min.	D max.	D1	D2	D3	D4	H	H1	H2	H3	H4	L	M	SW	Ball-Ø	No. of segments	F kN
K0358.101203	A	3,5	11,7	14,2	M4	10	1,5	4,3	15	10	4,2	3	1,5	3,5	2,5	3	2,5	3	0,5
K0358.101504	A	4,5	14,5	18,5	M4	12	2	4,3	19,5	14,5	9,8	8,6	2,3	5,5	3	3	4	3	3,5
K0358.101905	A	5,5	18,5	22,5	M5	15	2,5	5,3	23,5	16,5	11,6	10,4	2,3	7,5	3	4	4	3	4
K0358.102306	A	7	22,5	26,5	M6	20	3	6,4	28,6	19,8	14,2	13	2,3	6	4	5	4	3	4,5
K0358.102706	A	7	26,5	30,5	M6	20	3	6,4	28,6	19,8	14,2	13	2,3	6	4,5	5	4	3	4,5
K0358.103106	A	9	30,5	38,5	M6	25	4	6,4	32,7	23,1	14,2	11,9	4,6	7	4,5	5	8	3	4,5
K0358.103908	A	11	38,5	46,5	M8	30	4	8,4	39,2	27,2	17,8	15,5	4,6	7,5	4,5	6	8	6	6,5
K0358.104708	A	11	46,5	54,5	M8	30	4	8,4	39,2	27,2	18	15,7	4,6	7,5	4,5	6	8	6	6,5
K0358.105510	A	15	54,5	70,5	M10	45	5	10,5	54,6	40,6	23,7	19,1	9,3	9	5,5	8	16	6	8
K0358.107112	A	17	70,5	86,5	M12	60	5	13	63,1	46,1	28,3	23,7	9,3	10	5,5	10	16	6	10
K0358.108712	A	25	86,5	102,5	M16	60	5	17	73	51	30,2	23,7	9,3	10	5,5	14	16	6	12,5

KIPP Centring clamps with hexagon segments

Order No.	Form	A	D min.	D max.	D1	D2	D3	D4	H	H1	H2	H3	H4	L	M	SW	Hex	No. of segments	F kN
K0358.201504	B	4,5	14,5	18,5	M4	12	2	4,3	19,5	14,5	9,8	8,6	2,3	5,5	3	3	4	3	3,5
K0358.201905	B	5,5	18,5	22,5	M5	15	2,5	5,3	23,5	16,5	11,6	10,4	2,3	7,5	3	4	4	3	4
K0358.202306	B	7	22,5	26,5	M6	20	3	6,4	28,6	19,8	14,2	13	2,3	6	4	5	4	3	4,5
K0358.202706	B	7	26,5	30,5	M6	20	3	6,4	28,6	19,8	14,2	13	2,3	6	4,5	5	4	3	4,5
K0358.203106	B	9	30,5	38,5	M6	25	4	6,4	32,7	23,1	14,2	11,9	4,6	7	4,5	5	8	3	4,5
K0358.203908	B	11	38,5	46,5	M8	30	4	8,4	39,2	27,2	17,8	15,5	4,6	7,5	4,5	6	8	6	6,5
K0358.204708	B	11	46,5	54,5	M8	30	4	8,4	39,2	27,2	18	15,7	4,6	7,5	4,5	6	8	6	6,5
K0358.205510	B	15	54,5	70,5	M10	45	5	10,5	54,6	40,6	23,7	19,1	9,3	9	5,5	8	16	6	8
K0358.207112	B	17	70,5	86,5	M12	60	5	13	63,1	46,1	28,3	23,7	9,3	10	5,5	10	16	6	10
K0358.208712	B	25	86,5	102,5	M16	60	5	17	73	51	30,2	23,7	9,3	10	5,5	14	16	6	12,5

Centring clamps

with ball or hexagon segments

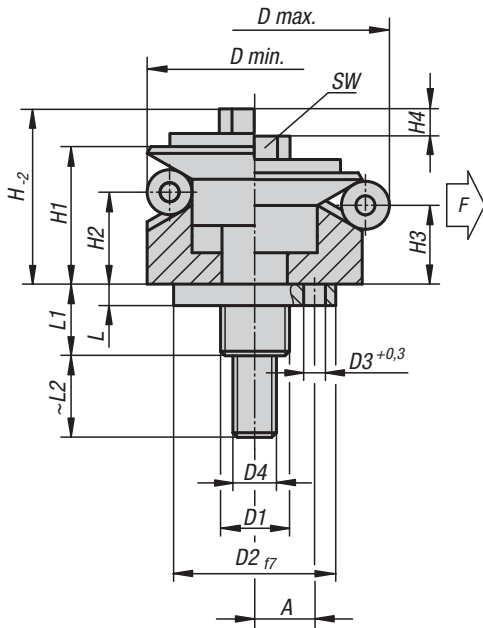

mounting dimensions

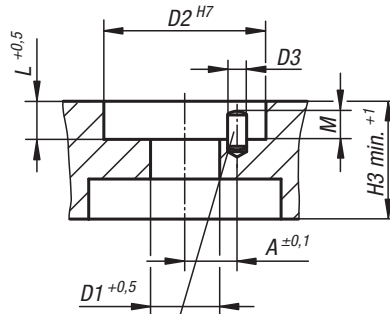

mounting aid:
pin to accurately position
the clamping segments



Material:

Body 1.2842.
Ball and hex segments 1.4112.
Tension spring 1.4310.

Version:

Body hardened and black oxidised.
Ball and hex segments hardened and ground.

Sample order:

K0644.0101203

Note:

Form A: With balls for holes where light marking is acceptable.
Form B: With hexagons for sensitive hole surfaces.

Application:

For centre positioning and clamping in blind holes.
Operated from below, manual or automatic using pneumatics or hydraulics.

Advantages:

- Precise self-centring.
- Distortion free clamping.
- Large spread range.
- Low overall height.
- Positive down force.

Technical data:

Repetitive accuracy ± 0.025
Concentric accuracy ± 0.05

Form A
spherical, point contact

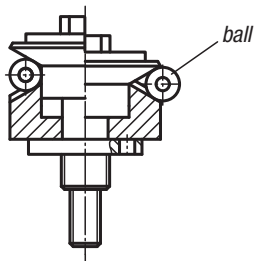

Form B
flat, non-marking

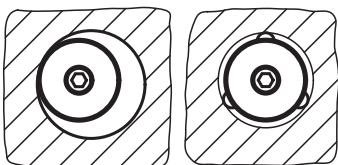
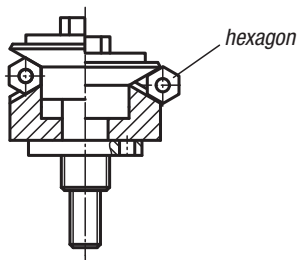

Centring clamps

with ball or hexagon segments

KIPP Centring clamps with ball segments

Order No.	Form	A	D min.	D max.	D1	D2	D3	D4	H	H1	H2	H3	H4	L	L1	L2	M	SW	Ball-Ø	No. of segments	F kN
K0644.0101203	A	3,5	11,7	14,2	M5	10	1,5	M3	12,8	10	4,2	3	1,5	3,5	11	8	2,5	5,5	2,5	3	0,5
K0644.0101503	A	4,5	14,5	18,5	M6	12	2	M3	17,3	14,5	9,8	8,6	2,3	5,5	14,1	8	3	5,5	4	3	3,5
K0644.0101904	A	5,5	18,5	22,5	M8	15	2,5	M4	20,9	16,5	11,6	10,4	2,3	7,5	18,2	8	3	7	4	3	4
K0644.0102305	A	7	22,5	26,5	M10	20	3	M5	25,4	19,8	14,2	13	2,3	6	17,4	11	4	8	4	3	4,5
K0644.0102705	A	7	26,5	30,5	M10	20	3	M5	25,4	19,8	14,2	13	2,3	6	17,4	10	4,5	8	4	3	4,5
K0644.0103106	A	9	30,5	38,5	M12	25	4	M6	30,3	23,1	14,2	11,9	4,6	7	21,9	13	4,5	10	8	3	4,5
K0644.0103906	A	11	38,5	46,5	M12	30	4	M6	34,2	27,2	17,8	15,5	4,6	7,5	22,5	12	4,5	10	8	6	6,5
K0644.0104706	A	11	46,5	54,5	M12	30	4	M6	34,2	27,2	18	15,7	4,6	7,5	22,5	12	4,5	10	8	6	6,5
K0644.0105508	A	15	54,5	70,5	M14	45	5	M8	49,9	40,6	23,7	19,1	9,7	9	24,5	16	5,5	13	16	6	8
K0644.0107108	A	17	70,5	86,5	M16	60	5	M8	55,4	46,1	28,3	23,7	9,9	10	29,4	17	5,5	13	16	6	10
K0644.0108708	A	25	86,5	102,5	M16	60	5	M10	61,6	51	30,2	25,7	9,2	10	29,4	17	5,5	16	16	6	12,5

KIPP Centring clamps with hexagon segments

Order No.	Form	A	D min.	D max.	D1	D2	D3	D4	H	H1	H2	H3	H4	L	L1	L2	M	SW	Hex	No. of segments	F kN
K0644.0201503	B	4,5	14,5	18,5	M6	12	2	M3	17,3	14,5	9,8	8,6	2,3	5,5	14,1	8	3	5,5	4	3	3,5
K0644.0201904	B	5,5	18,5	22,5	M8	15	2,5	M4	20,9	16,5	11,6	10,4	2,3	7,5	18,2	8	3	7	4	3	4
K0644.0202305	B	7	22,5	26,5	M10	20	3	M5	25,4	19,8	14,2	13	2,3	6	17,4	11	4	8	4	3	4,5
K0644.0202705	B	7	26,5	30,5	M10	20	3	M5	25,4	19,8	14,2	13	2,3	6	17,4	10	4,5	8	4	3	4,5
K0644.0203106	B	9	30,5	38,5	M12	25	4	M6	30,3	23,1	14,2	11,9	4,6	7	21,9	13	4,5	10	8	3	4,5
K0644.0203906	B	11	38,5	46,5	M12	30	4	M6	34,2	27,2	17,8	15,5	4,6	7,5	22,5	12	4,5	10	8	6	6,5
K0644.0204706	B	11	46,5	54,5	M12	30	4	M6	34,2	27,2	18	15,7	4,6	7,5	22,5	12	4,5	10	8	6	6,5
K0644.0205508	B	15	54,5	70,5	M14	45	5	M8	49,9	40,6	23,7	19,1	9,7	9	24,5	16	5,5	13	16	6	8
K0644.0207108	B	17	70,5	86,5	M16	60	5	M8	55,4	46,1	28,3	23,7	9,9	10	29,4	17	5,5	13	16	6	10
K0644.0208708	B	25	86,5	102,5	M16	60	5	M10	61,6	51	30,2	25,7	9,2	10	29,4	17	5,5	16	16	6	12,5

