

# Support elements, locating elements, stop elements



# Self-aligning pads



Form C  
external thread,  
flattened ball,  
flat face

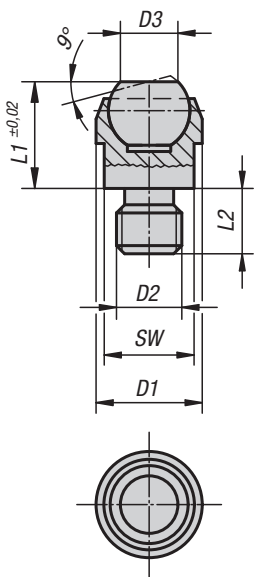

Form F  
external thread,  
flattened ball,  
diamond grip

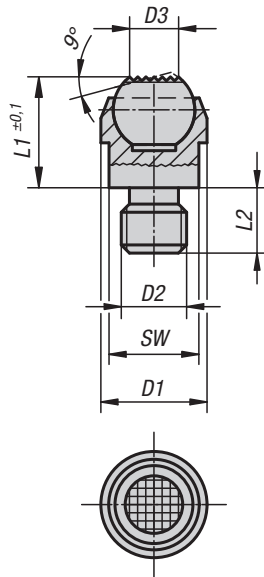

Form M  
external thread,  
flattened ball,  
diamond grip

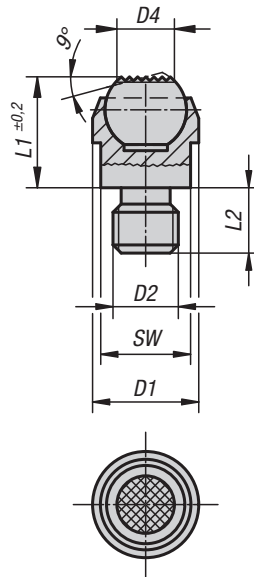

Form G  
press fit,  
flattened ball, flat face

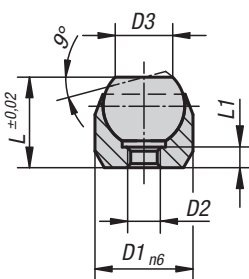

Form J  
press fit,  
flattened ball, diamond grip

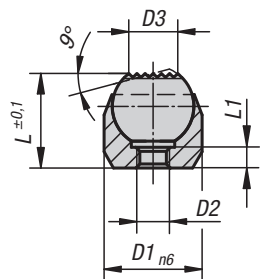

**Material:**  
Body carbon steel.  
Ball, ball bearing steel 1.2067.  
Form M has a carbide ball.

**Version:**  
Body tempered and phosphated.  
Ball hardened.  
Form M ball nickel plated.

**Sample order:**  
K0282.120

**Note:**  
Self-aligning pads serve as stops, supports and thrust pads in fixture constructions.

Ball secured against rotation.

\* Valid only if the minimum bore depth is observed.

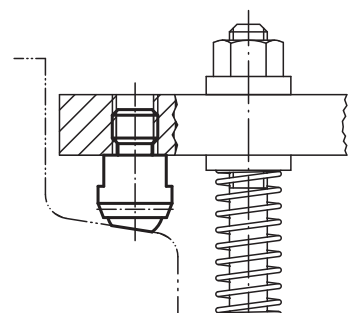

## KIPP Self-aligning pads

Order No.	Form	D1	D2	D3	L1	L2	Ball-Ø	SW	Load rating max. kN (static load only)
K0282.108	C	13	M8	7,2	13	8	10	11	10
K0282.110	C	20	M10	10,5	18	10	16	17	25
K0282.112	C	20	M12	10,5	18	12	16	17	25
K0282.116	C	30	M16	20	27	16	25	27	90
K0282.120	C	50	M20	34,5	35	20	40	41	165

Order No.	Form	D1	D2	D3	L1	L2	Ball-Ø	SW	Load rating max. kN (static load only)
K0282.308	F	13	M8	7,2	13	8	10	11	10
K0282.310	F	20	M10	10,5	18	10	16	17	25
K0282.312	F	20	M12	10,5	18	12	16	17	25
K0282.316	F	30	M16	20	27	16	25	27	90
K0282.320	F	50	M20	34,5	35	20	40	41	165

Order No.	Form	D1	D2	D4	L1	L2	SW	Ball-Ø	Load rating max. kN (static load only)
K0282.908	M	13	M8	7,7	13,3	8	11	10	10
K0282.910	M	20	M10	12	18	10	17	16	25
K0282.912	M	20	M12	12	18	12	17	16	25

Order No.	Form	D1	D2	D3	L	L1	Ball-Ø	Receiving hole	Load rating max. kN (static load only)
K0282.403	G	12	M3	7,2	11	3,5	10	Ø 12 H7 x 6 min.	10*
K0282.404	G	18	M4	10,5	17	4,4	16	Ø 18 H7 x 8 min.	25*
K0282.405	G	28	M5	20	25	6,3	25	Ø 28 H7 x 13 min.	90*

Order No.	Form	D1	D2	D3	L	L1	Ball-Ø	Receiving hole	Load rating max. kN (static load only)
K0282.603	J	12	M3	7,2	11	3,5	10	Ø 12 H7 x 6 min.	10*
K0282.604	J	18	M4	10,5	17	4,4	16	Ø 18 H7 x 8 min.	25*
K0282.605	J	28	M5	20	25	6,3	25	Ø 28 H7 x 13 min.	90*

## Self-aligning pads

swivel angle 12°



**Form C**  
external thread,  
flattened ball, flat face

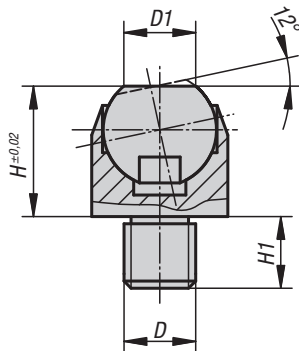

**Form F**  
external thread  
flattened ball, diamond grip

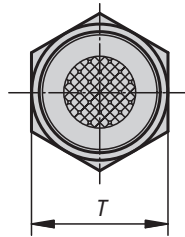
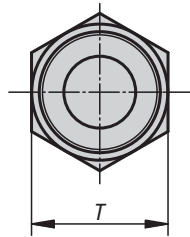
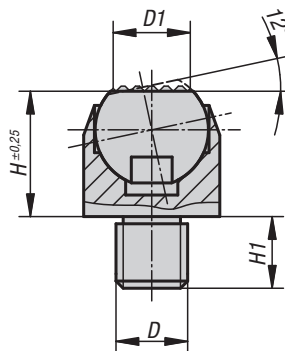

**Material:**

Body carbon steel, ball ball-bearing steel 1.3505.

**Version:**

Body tempered.  
Ball hardened (50 - 55 HRC).

**Sample order:**

K0302.106

**Note:**

Self-aligning pads serve as stops, supports and thrust pads in fixture construction. They can also be installed in existing clamping devices, e.g. „arness“ clamps.

Ball is secured against rotation.

### KIPP Self-aligning pads swivel angle 12°

Order No. Form C	Order No. Form F	D	D1	H	H1	Ball-Ø	T	Load rating max. kN (static load only)
K0302.106	K0302.306	M6	6,7	13	7	10	13	10
K0302.108	K0302.308	M8	6,7	13	8	10	13	10
K0302.110	K0302.310	M10	10	18	10	16	19	25
K0302.112	K0302.312	M12	10	18	12	16	19	25
K0302.116	K0302.316	M16	20	27	16	24	30	90
K0302.120	K0302.320	M20	20	27	20	24	30	90

## Self-aligning pads

swivel angle 14° and 20°



Form C  
flattened ball,  
flat face

Form M  
flattened ball,  
carbide steel diamond grip

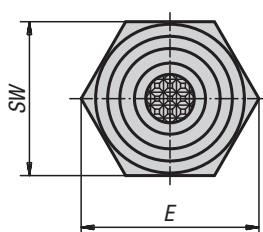
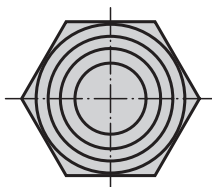
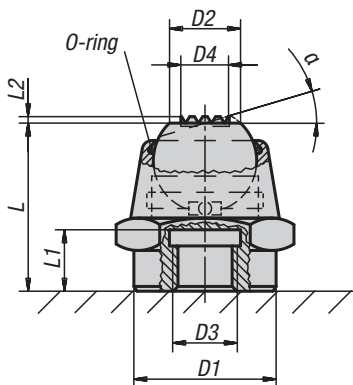
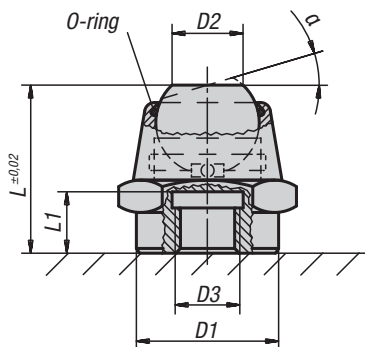

Type:  
K0283.1061  
K0283.1101  
K0283.1161

Type:  
K0283.9061  
K0283.9101  
K0283.9161

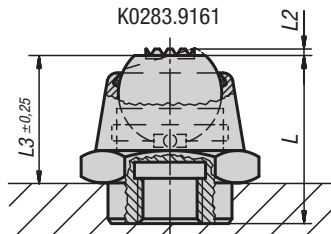
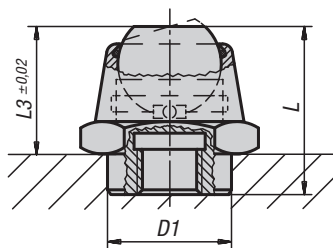

**Material:**  
Body steel.  
Ball rust and acid resistant steel.  
Form M with carbide insert.

**Version:**  
Body black oxidised.  
Ball bright.

**Sample order:**  
K0283.108

**Note:**  
Self-aligning pads are used to support and clamp unmachined and machined workpieces. They also serve as stops, supports and thrust pads in fixture and toolmaking.  
Grub screws or threaded studs can be screwed and glued into thread D3 making a self-aligning pad with external thread.

Ball secured against rotation.

**Advantages:**

- Self-aligning pads can be swiveled.
- High load forces can be absorbed.
- The built-in o-ring keeps dirt and foreign particles out, which in turn guarantees reliable operation.

### KIPP Self-aligning pads swivel angle 14° and 20°

Order No. Form C	Order No. Form M	α	D1	D2	D3	D4	L	L1	L2	L3	E	SW	Ball-Ø	Load rating max. kN (static load only)
K0283.1061	K0283.9061	14°	12	7	M6	-/5	17,5	6	-/0,6	12,5	19,6	17	10	14
K0283.106	K0283.906	14°	16	7	M6	-/5	17,5	6	-/0,6	-	19,6	17	10	14
K0283.108	K0283.908	20°	22	11	M8	-/7,5	26	9	-/0,8	-	27,7	24	16	34
K0283.1101	K0283.9101	20°	18	11	M10	-/7,5	26	9	-/0,8	20	27,7	24	16	34
K0283.110	K0283.910	20°	22	11	M10	-/7,5	26	9	-/0,8	-	27,7	24	16	34
K0283.112	K0283.912	20°	22	11	M12	-/7,5	26	9	-/0,8	-	27,7	24	16	34
K0283.1161	K0283.9161	20°	26	18	M16	-/13	40	15	-/0,9	30	41,6	36	25	90
K0283.116	K0283.916	20°	34	18	M16	-/13	40	15	-/0,9	-	41,6	36	25	90
K0283.120	K0283.920	20°	34	18	M20	-/13	40	15	-/0,9	-	41,6	36	25	90

# Self-aligning pads

with o-ring



Form C  
flattened steel ball, flat face

Form K  
flattened POM ball, flat face

Form F  
flattened steel ball,  
diamond grip

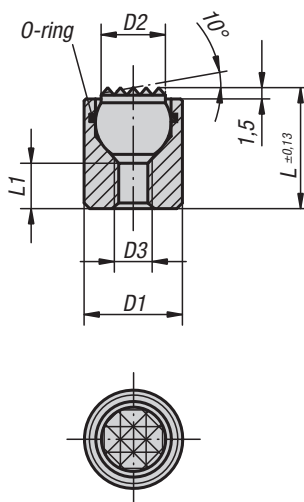
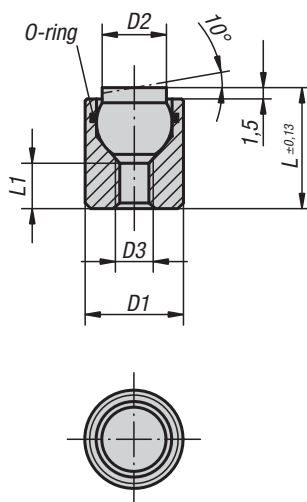

Form O  
stainless steel ball,  
diamond impregnated

Form P  
stainless steel ball  
PUR surface

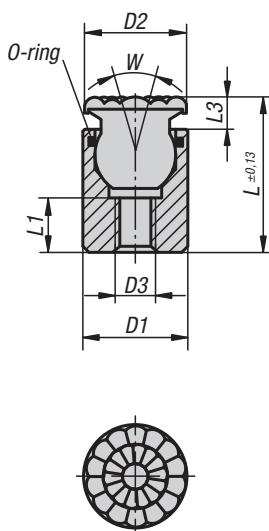
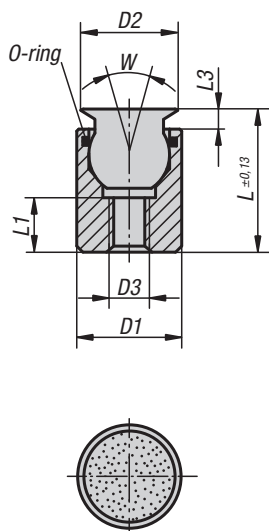

**Material:**

Body carbon steel.

Ball:

Form C, F tool steel.

Form K POM.

Form O stainless steel diamond impregnated.

Form P stainless steel with polyurethane face.

**Version:**

Body tempered, black oxidised.

Ball:

Form C, F hardened, black oxidised.

Form K POM ball, white.

Form O surface comparable to 100 grade abrasive grit.

Form P polyurethane, Shore hardness 60°.

**Sample order:**

K0284.704X012

**Note:**

Self-aligning pads are used to support and clamp unmachined and machined workpieces.

They also serve as stops, supports and thrust pads in fixtures and toolmaking.

Ball secured against rotation.

Form O: The abrasive diamond surface is fused firmly to the ball. It is ideally suited to supporting smooth or slippery applications with a minimum of clamping pressure. This allows the diamond particles to get a firm grip on a very small area with minimum damage to the surface. The diamond surface offers excellent wear resistance.

Form P: The polyurethane surface is permanently vulcanised on the ball. It is abrasion-resistant and does not discolour. Offers optimum protection against damage to delicate surfaces. The pearl-like surface gives a firm grip and allows air to escape so as to prevent any suction effect between the contact surface and the self-aligning pads.

**Advantages:**

The built-in O-ring holds the ball in place and keeps dirt and foreign particles out ensuring smooth and even movement.

## Self-aligning pads

with o-ring



## KIPP Self-aligning pads with o-ring

Order No.	Form	D1	D2	D3	L	L1	Ball-Ø	Load rating max. kN (static load only)
K0284.104X012	C	10	6	M4	12	4,5	7	12
K0284.104X025	C	10	6	M4	25	12	7	12
K0284.105X016	C	13	8,5	M5	16	5	10	20
K0284.105X025	C	13	8,5	M5	25	12	10	20

Order No.	Form	D1	D2	D3	L	L1	Ball-Ø	Load rating max. kN (static load only)
K0284.304X012	F	10	6	M4	12	4,5	7	12
K0284.304X025	F	10	6	M4	25	12	7	12
K0284.305X016	F	13	8,5	M5	16	5	10	20
K0284.305X025	F	13	8,5	M5	25	12	10	20

Order No.	Form	D1	D2	D3	L	L1	Ball-Ø	Load rating max. kN (static load only)
K0284.704X012	K	10	6	M4	12	4,5	7	2
K0284.704X025	K	10	6	M4	25	12	7	2
K0284.705X016	K	13	8,5	M5	16	5	10	4
K0284.705X025	K	13	8,5	M5	25	12	10	4

Order No.	Form	D1	D2	D3	L	L1	L3	W	Ball-Ø	Load rating max. kN (static load only)
K0284.504X012	O	10	8	M4	12,5	3,5	2	28	7	11,5
K0284.504X025	O	10	8	M4	25,5	9	2	28	7	11,5
K0284.505X017	O	13	11	M5	17,5	6,5	3	28	10	19,8
K0284.505X026	O	13	11	M5	26,5	9	3	28	10	19,8
K0284.506X021	O	17	14	M6	21	7,5	3	28	13	27,4
K0284.508X024	O	19	19	M8	24	8,5	4	24	15	38,6
K0284.510X028	O	24	21	M10	28	9	4	24	20	58,3

Order No.	Form	D1	D2	D3	L	L1	L3	W	Ball-Ø
K0284.604X014	P	10	10	M4	14,5	3,5	4	28	7
K0284.604X027	P	10	10	M4	27,5	9	4	28	7
K0284.605X019	P	13	13	M5	19,5	6,5	5	28	10
K0284.605X028	P	13	13	M5	28,5	9	5	28	10
K0284.606X023	P	17	16	M6	23	7,5	5	28	13
K0284.608X026	P	19	21	M8	26	8,5	6	24	15
K0284.610X030	P	24	23	M10	30	9	6	24	20

## Self-aligning pads

with o-ring and exchangeable inserts



Form C  
steel insert, flat face

Form E  
stainless steel insert,  
flat face

Form K  
POM insert, flat face

Form F  
diamond grip insert

Form M  
carbide steel  
diamond grip insert

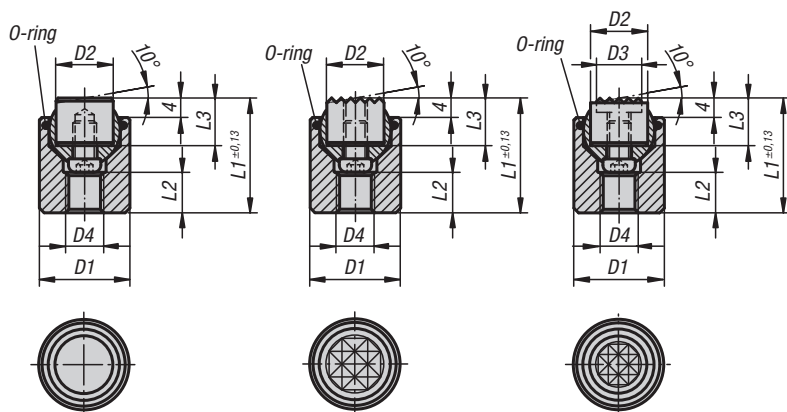

Form O  
stainless steel insert  
diamond impregnated

Form P  
stainless steel insert  
PUR surface

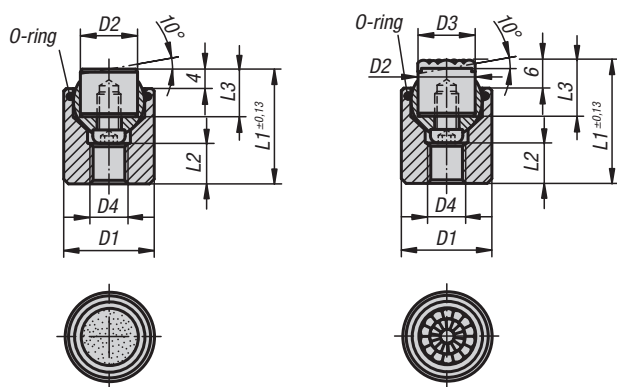

### Material:

Body carbon steel.  
Ball rust and acid resistant steel.  
Inserts:  
Form C, F, M tool steel  
Form K POM  
Form E stainless steel.  
Form O stainless steel diamond impregnated.  
Form P stainless steel with polyurethane surface.

### Version:

Body tempered, black oxidised.  
Ball hardened, bright.  
Inserts:  
Form C, F hardened, black oxidised.  
Form M with carbide serrations, black oxidised.  
Form K white.  
Form E hardened, bright.  
Form O diamond impregnated surface comparable to 100 grade abrasive grit.  
Form P polyurethane surface, hardness 60° Shore.

### Sample order:

K0285.736X036

### Note:

Self-aligning pads are used to support and clamp unmachined and machined workpieces. In addition, they serve as stops, supports and thrust pads in fixtures and toolmaking. The ball can be removed from the housing by applying light pressure to the socket head screw.

Ball secured against rotation.

### Advantages:

Highly cost-effective as inserts can be exchanged. The built-in O-ring holds the ball in place and keeps dirt and foreign particles out, ensuring uniform movement.

## KIPP Self-aligning pads with o-ring and exchangeable inserts

Order No.	Form	D1	D2	D4	L1	L2	L3	Ball-Ø	Load rating max. kN (static load only)	Order No. steel insert
K0285.117X022	C	17	10	M6	22	7	10	13	28	K0385.10108
K0285.119X024	C	19	12	M8	24	8	10	15	39	K0385.12108
K0285.124X028	C	24	16	M10	28	8	10	20	58	K0385.16108
K0285.130X030	C	30	20	M12	30	9	10	23	95	K0385.20108
K0285.136X036	C	36	25	M12	36	11	10	28	136	K0385.25108



Order No.	Form	D1	D2	D4	L1	L2	L3	Ball-Ø	Load rating max. kN (static load only)	Order No. stainless steel insert
K0285.217X022	E	17	10	M6	22	7	10	13	28	K0385.10102
K0285.219X024	E	19	12	M8	24	8	10	15	39	K0385.12102
K0285.224X028	E	24	16	M10	28	8	10	20	58	K0385.16102
K0285.230X030	E	30	20	M12	30	9	10	23	95	K0385.20102
K0285.236X036	E	36	25	M12	36	11	10	28	136	K0385.25102

Order No.	Form	D1	D2	D4	L1	L2	L3	Ball-Ø	Load rating max. kN (static load only)	Order No. gripper
K0285.317X022	F	17	10	M6	22	7	10	13	28	K0385.1010
K0285.319X024	F	19	12	M8	24	8	10	15	39	K0385.1210
K0285.324X028	F	24	16	M10	28	8	10	20	58	K0385.1610
K0285.330X030	F	30	20	M12	30	9	10	23	95	K0385.2010
K0285.336X036	F	36	25	M12	36	11	10	28	136	K0385.2510

Order No.	Form	D1	D2	D4	L1	L2	L3	Ball-Ø	Load rating max. kN (static load only)	Order No. POM insert
K0285.717X022	K	17	10	M6	22	7	10	13	4	K0385.10109
K0285.719X024	K	19	12	M8	24	8	10	15	7	K0385.12109
K0285.724X028	K	24	16	M10	28	8	10	20	14	K0385.16109
K0285.730X030	K	30	20	M12	30	9	10	23	27	K0385.20109
K0285.736X036	K	36	25	M12	36	11	10	28	47	K0385.25109

Order No.	Form	D1	D2	D3	D4	L1	L2	L3	Ball-Ø	Load rating max. kN (static load only)	Order No. gripper
K0285.917X022	M	17	10	7,9	M6	22	7	10	13	28	K0385.10107
K0285.919X024	M	19	12	9,5	M8	24	8	10	15	39	K0385.12107
K0285.924X028	M	24	16	12,7	M10	28	8	10	20	58	K0385.16107
K0285.930X030	M	30	20	15,9	M12	30	9	10	23	95	K0385.20107
K0285.936X036	M	36	25	19	M12	36	11	10	28	136	K0385.25107

Order No.	Form	D1	D2	D4	L1	L2	L3	Ball-Ø	Load rating max. kN (static load only)	Order No. stainless steel insert, diamond surface
K0285.517X022	O	17	10	M6	22	7	10	13	28	K0385.10105
K0285.519X024	O	19	12	M8	24	8	10	15	39	K0385.12105
K0285.524X028	O	24	16	M10	28	8	10	20	58	K0385.16105
K0285.530X030	O	30	20	M12	30	9	10	23	95	K0385.20105
K0285.536X036	O	36	25	M12	36	11	10	28	136	K0385.25105

Order No.	Form	D1	D2	D3	D4	L1	L2	L3	Ball-Ø	Order No. stainless steel insert, polyurethane surface
K0285.617X024	P	17	10	10	M6	24	7	12	13	K0385.10126
K0285.619X026	P	19	12	13	M8	26	8	12	15	K0385.12126
K0285.624X030	P	24	16	16	M10	30	8	12	20	K0385.16126
K0285.630X032	P	30	20	21	M12	32	9	12	23	K0385.20126
K0285.636X038	P	36	25	27	M12	38	11	12	28	K0385.25126

## Self-aligning pads

self-righting



Form C  
flat face

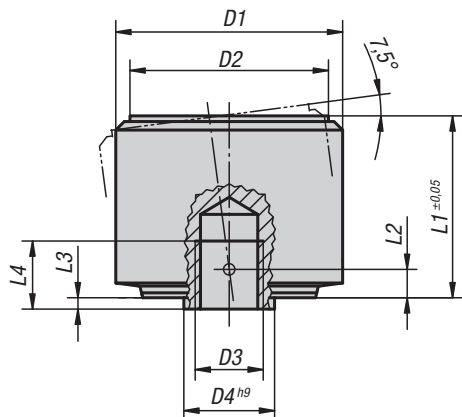

Form F  
diamond grip face

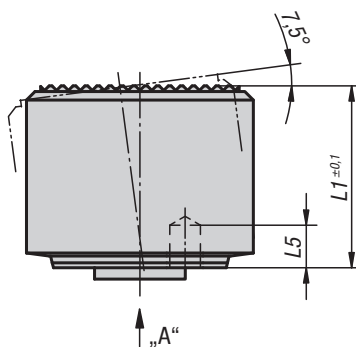

view "A"

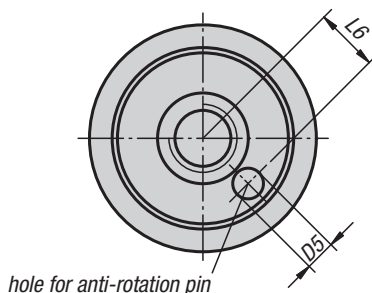

hole for anti-rotation pin

**Material:**  
Carbon steel.

**Version:**  
Hardened, black oxidised.

**Sample order:**  
K0286.105

**Note:**  
Self-aligning pads are used to support and clamp unmachined and machined workpieces. They also serve as stops, supports and thrust pads in fixtures and toolmaking.

**Advantages:**

- The built-in o-ring prevents dirt and foreign particles from entering.
- The clamping surface swivels back automatically after clamping.
- High load rating and small size.

1. bring gripper into position

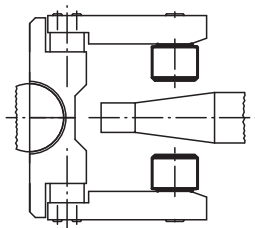

zero-point position of self-aligning pads

2. grip workpiece

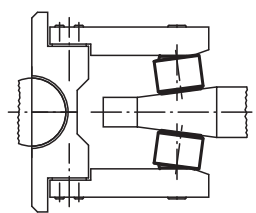

self-aligning pads adapt to workpiece contour

3. open gripper

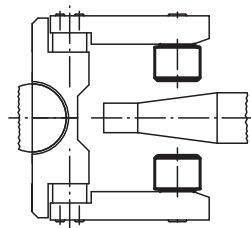

self-aligning pads swivel back automatically

### KIPP Self-aligning pads self-righting

Order No.	Form	D1	D2	D3	D4	D5	L1	L2	L3	L4	L5	L6	Load rating max. kN (static load only)
K0286.105	C	18	15	M5	7	1,8	14	2,1	0,8	5	3	4,6	30
K0286.106	C	22	18	M6	8	2,8	16,5	2,5	1	6	4	5,6	50
K0286.108	C	28	23	M8	11	3,3	21,5	3,4	1,3	8	5	7,5	90
K0286.110	C	34	29	M10	13	4,4	27	4,2	1,6	10	6	9,2	140
K0286.112	C	40	35	M12	16	5,4	32	5	2	12	8	11,3	220
K0286.305	F	18	15	M5	7	1,8	14	2,1	0,8	5	3	4,6	30
K0286.306	F	22	18	M6	8	2,8	16,5	2,5	1	6	4	5,6	50
K0286.308	F	28	23	M8	11	3,3	21,5	3,4	1,3	8	5	7,5	90
K0286.310	F	34	29	M10	13	4,4	27	4,2	1,6	10	6	9,2	140
K0286.312	F	40	35	M12	16	5,4	32	5	2	12	8	11,3	220

## Self-aligning pads

adjustable



Form C  
flattened ball, flat face

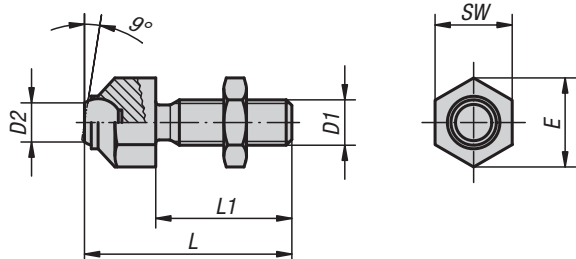

Form F  
flattened ball, diamond grip

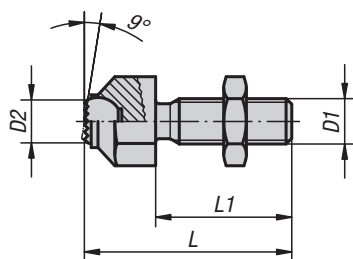

**Material:**  
Steel or stainless steel

**Version:**  
Steel version:  
Housing tempered and manganese phosphated.  
Nut black oxidised. .

Stainless steel version:  
Housing tempered and electropolished.  
Nut bright.

**Sample order:**  
K0287.316

**Note:**  
Ball secured against rotation.

### KIPP Self-aligning pads adjustable

Order No.	Material	Form	D1	D2	L	L1	E	SW	Ball-Ø	Load rating max. kN (static load only)
K0287.108	Steel	C	M8	5,8	36,6	25	14,5	13	8,5	8
K0287.110	Steel	C	M10	8,6	45,7	30	19	17	12	8
K0287.112	Steel	C	M12	8,6	50,7	35	19	17	12	15
K0287.116	Steel	C	M16	10,5	60,7	40	27	24	16	25
K0287.120	Steel	C	M20	20	77,3	50	33	30	25	90
K0287.1081	Stainless steel	C	M8	5,8	36,6	25	14,5	13	8,5	8
K0287.1101	Stainless steel	C	M10	8,6	45,7	30	19	17	12	8
K0287.1121	Stainless steel	C	M12	8,6	50,7	35	19	17	12	15
K0287.1161	Stainless steel	C	M16	10,5	60,7	40	27	24	16	25
K0287.1201	Stainless steel	C	M20	20	77,3	50	33	30	25	90
K0287.308	Steel	F	M8	5,8	36,6	25	14,5	13	8,5	8
K0287.310	Steel	F	M10	8,6	45,7	30	19	17	12	8
K0287.312	Steel	F	M12	8,6	50,7	35	19	17	12	15
K0287.316	Steel	F	M16	10,5	60,7	40	27	24	16	25
K0287.320	Steel	F	M20	20	77,3	50	33	30	25	90
K0287.3081	Stainless steel	F	M8	5,8	36,6	25	14,5	13	8,5	8
K0287.3101	Stainless steel	F	M10	8,6	45,7	30	19	17	12	8
K0287.3121	Stainless steel	F	M12	8,6	50,7	35	19	17	12	15
K0287.3161	Stainless steel	F	M16	10,5	60,7	40	27	24	16	25
K0287.3201	Stainless steel	F	M20	20	77,3	50	33	30	25	90

# Self-aligning pads

adjustable, with o-ring



Form C  
steel ball, flat face

Form K  
POM ball, flat face

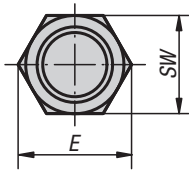
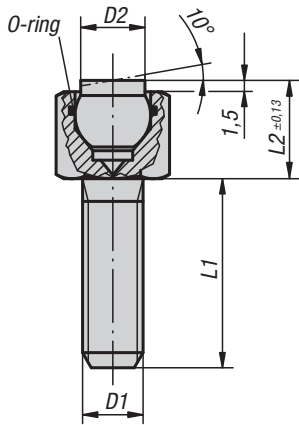

Form O  
stainless steel ball  
diamond impregnated

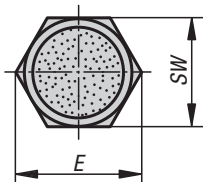
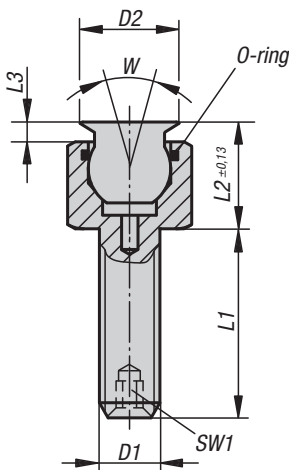

Form F  
steel ball, diamond grip

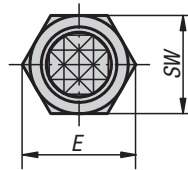
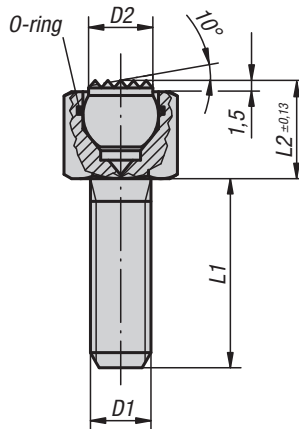

Form P  
stainless steel ball  
PUR surface

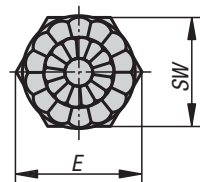
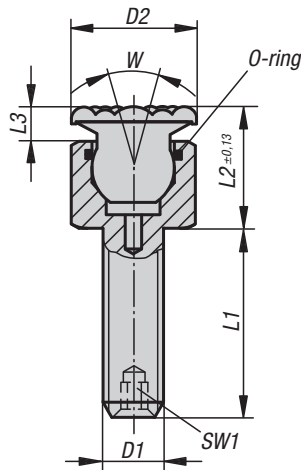

**Material:**

Body carbon steel.  
Ball:  
Form C, F, tool steel.  
Form K POM.  
Form O stainless steel diamond impregnated.  
Form P stainless steel with polyurethane surface.

**Version:**

Body tempered, black oxidised.  
Ball:  
Form C, F hardened, black oxidised.  
Form K POM ball white.  
Form O surface comparable to 100 grade abrasive grit.  
Form P polyurethane Shore hardness 60°.

**Sample order:**

K0288.506X012  
(include length L1)

**Note:**

Self-aligning pads are used to support and clamp unmachined and machined workpieces. They also serve as stops, supports and thrust pads in fixtures and toolmaking.

Ball secured against rotation.

Form O: The abrasive diamond surface is bonded firmly to the ball. It is ideally suited to supporting smooth or slippery applications with a minimum of clamping pressure. This allows the diamond particles to get a firm grip on a very small area with minimum damage to the surface.

The diamond surface offers excellent wear resistance.

Form P: The polyurethane surface is vulcanised firmly to the ball. It is abrasion-resistant and does not discolour.

It offers optimum protection against damage to delicate surfaces. The pearl-like surface gives a firm grip and allows air to escape so as to prevent any suction effect between the contact surface and the self-aligning pads.

**Advantages:**

The built-in O-ring holds the ball in place and keeps dirt and foreign particles out, ensuring uniform movement.

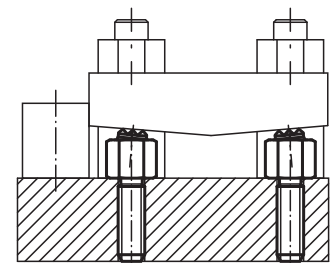

# Self-aligning pads

adjustable, with o-ring



## KIPP Self-aligning pads adjustable with o-ring

Order No.	Form	D1	D2	L1	L2	E	SW	Ball-Ø	Load rating max. kN (static load only)
K0288.106X012	C	M6	6	12	9,5	11,5	10	7	9
K0288.106X025	C	M6	6	25	9,5	11,5	10	7	9
K0288.106X040	C	M6	6	40	9,5	11,5	10	7	9
K0288.108X012	C	M8	8,5	12	13	15	13	10	15
K0288.108X025	C	M8	8,5	25	13	15	13	10	15
K0288.108X040	C	M8	8,5	40	13	15	13	10	15

Order No.	Form	D1	D2	L1	L2	E	SW	Ball-Ø	Load rating max. kN (static load only)
K0288.306X012	F	M6	6	12	9,5	11,5	10	7	9
K0288.306X025	F	M6	6	25	9,5	11,5	10	7	9
K0288.306X040	F	M6	6	40	9,5	11,5	10	7	9
K0288.308X012	F	M8	8,5	12	13	15	13	10	15
K0288.308X025	F	M8	8,5	25	13	15	13	10	15
K0288.308X040	F	M8	8,5	40	13	15	13	10	15

Order No.	Form	D1	D2	L1	L2	E	SW	Ball-Ø	Load rating max. kN (static load only)
K0288.706X012	K	M6	6	12	9,5	11,5	10	7	2
K0288.706X025	K	M6	6	25	9,5	11,5	10	7	2
K0288.706X040	K	M6	6	40	9,5	11,5	10	7	2
K0288.708X012	K	M8	8,5	12	13	15	13	10	4
K0288.708X025	K	M8	8,5	25	13	15	13	10	4
K0288.708X040	K	M8	8,5	40	13	15	13	10	4

Order No.	Form	D1	D2	L1	L2	L3	E	SW	SW1	W	Ball-Ø	Load rating max. kN (static load only)
K0288.506X	O	M6	8	12/25/40	10	2	11,5	10	-	28	7	9,2
K0288.508X	O	M8	11	12/25/40	14,5	3	15	13	-	28	10	15,5
K0288.510X	O	M10	14	15/30/50	16	3	19,6	17	3	28	13	18,8
K0288.512X	O	M12	19	20/40/60	19	4	21,9	19	5	24	15	29,8
K0288.516X	O	M16	21	25/50/80	23	4	27,7	24	6	24	20	50,3

Order No.	Form	D1	D2	L1	L2	L3	E	SW	SW1	W	Ball-Ø
K0288.606X	P	M6	10	12/25/40	12	4	11,5	10	-	28	7
K0288.608X	P	M8	13	12/25/40	16,5	5	15	13	-	28	10
K0288.610X	P	M10	16	15/30/50	18	5	19,6	17	3	28	13
K0288.612X	P	M12	21	20/40/60	21	6	21,9	19	5	24	15
K0288.616X	P	M16	23	25/50/80	25	6	27,7	24	6	24	20

# Self-aligning pads

adjustable, with o-ring and exchangeable inserts



Form C  
steel insert, flat face

Form F  
diamond grip insert

Form M  
carbide steel  
diamond grip

Form E  
stainless steel insert, flat face

Form K  
POM insert, flat face

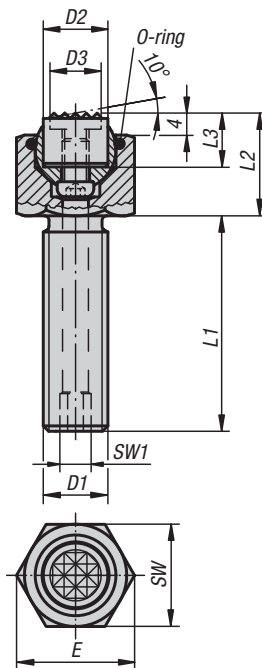
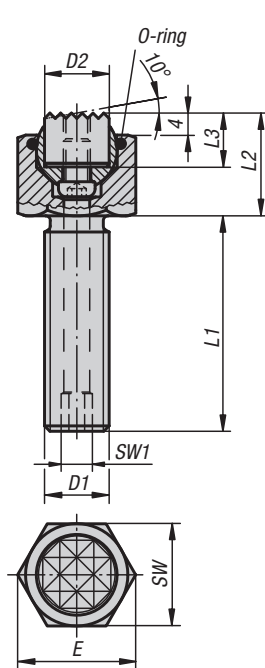
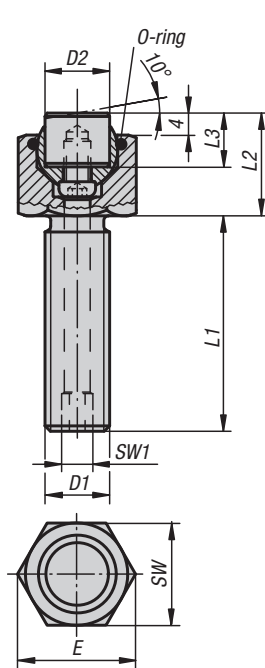

Form O  
stainless steel insert  
diamond impregnated

Form P  
stainless steel insert,  
PUR surface

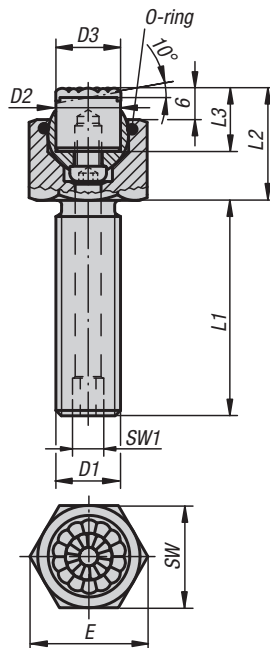
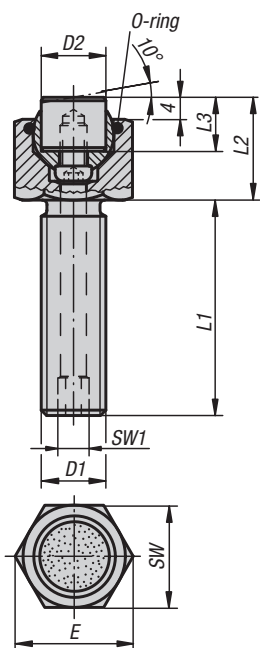

**Material:**

Body carbon steel.  
Ball rust and acid resistant steel.  
Inserts:  
Form C, F, M tool steel  
Form K POM  
Form E stainless steel.  
Form O stainless steel diamond impregnated.  
Form P stainless steel with polyurethane surface.

**Version:**

Body tempered, black oxidised.  
Ball hardened, bright.  
Inserts:  
Form C, F hardened, black oxidised.  
Form M with carbide serrations, black oxidised.  
Form K white.  
Form E hardened, bright.  
Form O diamond impregnated surface comparable to 100 grade abrasive grit.  
Form P polyurethane surface, hardness 60° Shore.

**Sample order:**  
K0289.124X100

**Note:**

Self-aligning pads are used to support and clamp unmachined and machined workpieces. They also serve as stops, supports and thrust pads in fixtures and toolmaking. The ball can be removed from the housing by applying light pressure to the socket head screw.

Ball secured against rotation.

**Advantages:**

Highly cost-effective as inserts can be exchanged. The built-in O-ring holds the ball in place and keeps dirt and foreign particles out, ensuring uniform movement.

## Self-aligning pads

adjustable, with o-ring and exchangeable inserts



Order No.	Form	D1	D2	L1	L2	L3	E	SW	SW1	Ball-Ø	Load rating max. kN (static load only)	Order No. steel insert
K0289.110X015	C	M10	10	15	17	10	19,6	17	3	13	19	K0385.10108
K0289.110X030	C	M10	10	30	17	10	19,6	17	3	13	19	K0385.10108
K0289.110X050	C	M10	10	50	17	10	19,6	17	3	13	19	K0385.10108
K0289.112X020	C	M12	12	20	19	10	21,9	19	5	15	30	K0385.12108
K0289.112X040	C	M12	12	40	19	10	21,9	19	5	15	30	K0385.12108
K0289.112X060	C	M12	12	60	19	10	21,9	19	5	15	30	K0385.12108
K0289.116X025	C	M16	16	25	23	10	27,7	24	6	20	50	K0385.16108
K0289.116X050	C	M16	16	50	23	10	27,7	24	6	20	50	K0385.16108
K0289.116X080	C	M16	16	80	23	10	27,7	24	6	20	50	K0385.16108
K0289.120X030	C	M20	20	30	24	10	34,6	30	8	23	85	K0385.20108
K0289.120X060	C	M20	20	60	24	10	34,6	30	8	23	85	K0385.20108
K0289.120X100	C	M20	20	100	24	10	34,6	30	8	23	85	K0385.20108
K0289.124X040	C	M24	25	40	30	10	41,6	36	10	28	121	K0385.25108
K0289.124X100	C	M24	25	100	30	10	41,6	36	10	28	121	K0385.25108

Order No.	Form	D1	D2	L1	L2	L3	E	SW	SW1	Ball-Ø	Load rating max. kN (static load only)	Order No. stainless steel insert
K0289.210X015	E	M10	10	15	17	10	19,6	17	3	13	19	K0385.10102
K0289.210X030	E	M10	10	30	17	10	19,6	17	3	13	19	K0385.10102
K0289.210X050	E	M10	10	50	17	10	19,6	17	3	13	19	K0385.10102
K0289.212X020	E	M12	12	20	19	10	21,9	19	5	15	30	K0385.12102
K0289.212X040	E	M12	12	40	19	10	21,9	19	5	15	30	K0385.12102
K0289.212X060	E	M12	12	60	19	10	21,9	19	5	15	30	K0385.12102
K0289.216X025	E	M16	16	25	23	10	27,7	24	6	20	50	K0385.16102
K0289.216X050	E	M16	16	50	23	10	27,7	24	6	20	50	K0385.16102
K0289.216X080	E	M16	16	80	23	10	27,7	24	6	20	50	K0385.16102
K0289.220X030	E	M20	20	30	24	10	34,6	30	8	23	85	K0385.20102
K0289.220X060	E	M20	20	60	24	10	34,6	30	8	23	85	K0385.20102
K0289.220X100	E	M20	20	100	24	10	34,6	30	8	23	85	K0385.20102
K0289.224X040	E	M24	25	40	30	10	41,6	36	10	28	121	K0385.25102
K0289.224X100	E	M24	25	100	30	10	41,6	36	10	28	121	K0385.25102

Order No.	Form	D1	D2	L1	L2	L3	E	SW	SW1	Ball-Ø	Load rating max. kN (static load only)	Order No. gripper
K0289.310X015	F	M10	10	15	17	10	19,6	17	3	13	19	K0385.1010
K0289.310X030	F	M10	10	30	17	10	19,6	17	3	13	19	K0385.1010
K0289.310X050	F	M10	10	50	17	10	19,6	17	3	13	19	K0385.1010
K0289.312X020	F	M12	12	20	19	10	21,9	19	5	15	30	K0385.1210
K0289.312X040	F	M12	12	40	19	10	21,9	19	5	15	30	K0385.1210
K0289.312X060	F	M12	12	60	19	10	21,9	19	5	15	30	K0385.1210
K0289.316X025	F	M16	16	25	23	10	27,7	24	6	20	50	K0385.1610
K0289.316X050	F	M16	16	50	23	10	27,7	24	6	20	50	K0385.1610
K0289.316X080	F	M16	16	80	23	10	27,7	24	6	20	50	K0385.1610
K0289.320X030	F	M20	20	30	24	10	34,6	30	8	23	85	K0385.2010
K0289.320X060	F	M20	20	60	24	10	34,6	30	8	23	85	K0385.2010
K0289.320X100	F	M20	20	100	24	10	34,6	30	8	23	85	K0385.2010
K0289.324X040	F	M24	25	40	30	10	41,6	36	10	28	121	K0385.2510
K0289.324X100	F	M24	25	100	30	10	41,6	36	10	28	121	K0385.2510

# Self-aligning pads

adjustable, with o-ring and exchangeable inserts



Order No.	Form	D1	D2	L1	L2	L3	E	SW	SW1	Ball-Ø	Load rating max. kN (static load only)	Order No. POM insert
K0289.710X015	K	M10	10	15	17	10	19,6	17	3	13	4	K0385.10109
K0289.710X030	K	M10	10	30	17	10	19,6	17	3	13	4	K0385.10109
K0289.710X050	K	M10	10	50	17	10	19,6	17	3	13	4	K0385.10109
K0289.712X020	K	M12	12	20	19	10	21,9	19	5	15	7	K0385.12109
K0289.712X040	K	M12	12	40	19	10	21,9	19	5	15	7	K0385.12109
K0289.712X060	K	M12	12	60	19	10	21,9	19	5	15	7	K0385.12109
K0289.716X025	K	M16	16	25	23	10	27,7	24	6	20	14	K0385.16109
K0289.716X050	K	M16	16	50	23	10	27,7	24	6	20	14	K0385.16109
K0289.716X080	K	M16	16	80	23	10	27,7	24	6	20	14	K0385.16109
K0289.720X030	K	M20	20	30	24	10	34,6	30	8	23	27	K0385.20109
K0289.720X060	K	M20	20	60	24	10	34,6	30	8	23	27	K0385.20109
K0289.720X100	K	M20	20	100	24	10	34,6	30	8	23	27	K0385.20109
K0289.724X040	K	M24	25	40	30	10	41,6	36	10	28	47	K0385.25109
K0289.724X100	K	M24	25	100	30	10	41,6	36	10	28	47	K0385.25109

Order No.	Form	D1	D2	D3	L1	L2	L3	E	SW	SW1	Ball-Ø	Load rating max. kN (static load only)	Order No. gripper
K0289.910X015	M	M10	10	7,9	15	17	10	19,6	17	3	13	19	K0385.10107
K0289.910X030	M	M10	10	7,9	30	17	10	19,6	17	3	13	19	K0385.10107
K0289.910X050	M	M10	10	7,9	50	17	10	19,6	17	3	13	19	K0385.10107
K0289.912X020	M	M12	12	9,5	20	19	10	21,9	19	5	15	30	K0385.12107
K0289.912X040	M	M12	12	9,5	40	19	10	21,9	19	5	15	30	K0385.12107
K0289.912X060	M	M12	12	9,5	60	19	10	21,9	19	5	15	30	K0385.12107
K0289.916X025	M	M16	16	12,7	25	23	10	27,7	24	6	20	50	K0385.16107
K0289.916X050	M	M16	16	12,7	50	23	10	27,7	24	6	20	50	K0385.16107
K0289.916X080	M	M16	16	12,7	80	23	10	27,7	24	6	20	50	K0385.16107
K0289.920X030	M	M20	20	15,9	30	24	10	34,6	30	8	23	85	K0385.20107
K0289.920X060	M	M20	20	15,9	60	24	10	34,6	30	8	23	85	K0385.20107
K0289.920X100	M	M20	20	15,9	100	24	10	34,6	30	8	23	85	K0385.20107
K0289.924X040	M	M24	25	19	40	30	10	41,6	36	10	28	121	K0385.25107
K0289.924X100	M	M24	25	19	100	30	10	41,6	36	10	28	121	K0385.25107



# Self-aligning pads

adjustable, with o-ring and exchangeable inserts



Order No.	Form	D1	D2	L1	L2	L3	E	SW	SW1	Ball-Ø	Load rating max. kN (static load only)	Order No. stainless steel insert, diamond surface
K0289.510X015	O	M10	10	15	17	10	19,6	17	3	13	19	K0385.10105
K0289.510X030	O	M10	10	30	17	10	19,6	17	3	13	19	K0385.10105
K0289.510X050	O	M10	10	50	17	10	19,6	17	3	13	19	K0385.10105
K0289.512X020	O	M12	12	20	19	10	21,9	19	5	15	30	K0385.12105
K0289.512X040	O	M12	12	40	19	10	21,9	19	5	15	30	K0385.12105
K0289.512X060	O	M12	12	60	19	10	21,9	19	5	15	30	K0385.12105
K0289.516X025	O	M16	16	25	23	10	27,7	24	6	20	50	K0385.16105
K0289.516X050	O	M16	16	50	23	10	27,7	24	6	20	50	K0385.16105
K0289.516X080	O	M16	16	80	23	10	27,7	24	6	20	50	K0385.16105
K0289.520X030	O	M20	20	30	24	10	34,6	30	8	23	85	K0385.20105
K0289.520X060	O	M20	20	60	24	10	34,6	30	8	23	85	K0385.20105
K0289.520X100	O	M20	20	100	24	10	34,6	30	8	23	85	K0385.20105
K0289.524X040	O	M24	25	40	30	10	41,6	36	10	28	121	K0385.25105
K0289.524X100	O	M24	25	100	30	10	41,6	36	10	28	121	K0385.25105

Order No.	Form	D1	D2	D3	L1	L2	L3	E	SW	SW1	Ball-Ø	Order No. stainless steel insert, polyurethane surface
K0289.610X015	P	M10	10	10	15	19	12	19,6	17	3	13	K0385.10126
K0289.610X030	P	M10	10	10	30	19	12	19,6	17	3	13	K0385.10126
K0289.610X050	P	M10	10	10	50	19	12	19,6	17	3	13	K0385.10126
K0289.612X020	P	M12	12	13	20	21	12	21,9	19	5	15	K0385.12126
K0289.612X040	P	M12	12	13	40	21	12	21,9	19	5	15	K0385.12126
K0289.612X060	P	M12	12	13	60	21	12	21,9	19	5	15	K0385.12126
K0289.616X025	P	M16	16	16	25	25	12	27,7	24	6	20	K0385.16126
K0289.616X050	P	M16	16	16	50	25	12	27,7	24	6	20	K0385.16126
K0289.616X080	P	M16	16	16	80	25	12	27,7	24	6	20	K0385.16126
K0289.620X030	P	M20	20	21	30	26	12	34,6	30	8	23	K0385.20126
K0289.620X060	P	M20	20	21	60	26	12	34,6	30	8	23	K0385.20126
K0289.620X100	P	M20	20	21	100	26	12	34,6	30	8	23	K0385.20126
K0289.624X040	P	M24	25	27	40	32	12	41,6	36	10	28	K0385.25126
K0289.624X100	P	M24	25	27	100	32	12	41,6	36	10	28	K0385.25126

## Self-aligning pads

adjustable, with o-ring and hexagon socket



Form C  
flattened steel ball,  
flat face  
Form K  
flattened POM ball, flat face

Form F  
flattened steel ball,  
diamond grip

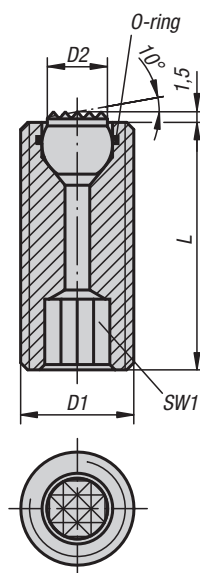
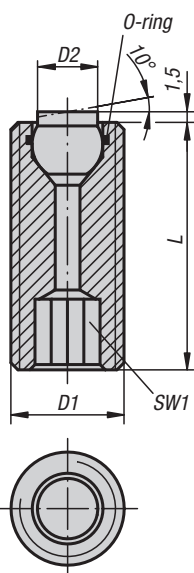

Form O  
stainless steel ball  
diamond impregnated

Form P  
stainless steel ball,  
PUR surface

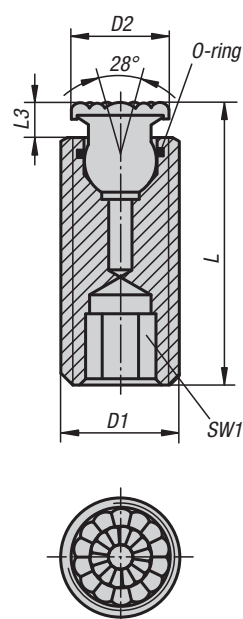
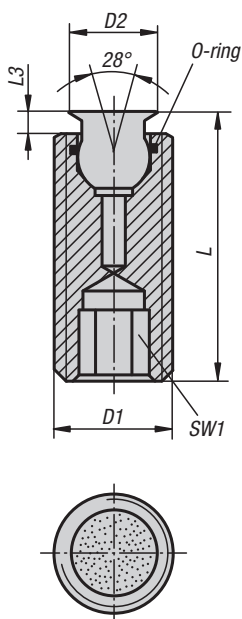

**Material:**  
Body carbon steel.  
Ball:  
Form C, F, tool steel.  
Form K POM.  
Form O stainless steel diamond impregnated.  
Form P stainless steel with polyurethane surface.

**Version:**  
Body tempered, black oxidised.  
Ball:  
Form C, F hardened, black oxidised.  
Form K POM ball white.  
Form O surface comparable to 100 grade abrasive grit.  
Form P polyurethane, Shore hardness 60°.

**Sample order:**  
K0290.510X026  
(include length L)

**Note:**  
Self-aligning pads are used to support and clamp unmachined and machined workpieces. They also serve as stops, supports and thrust pads in fixtures and toolmaking.

Ball secured against rotation.

Form O: The abrasive diamond surface is bonded firmly to the ball. It is ideally suited to supporting smooth or slippery applications with a minimum of clamping pressure. This allows the diamond particles to get a firm grip on a very small area with minimum damage to the surface. The diamond surface offers excellent wear resistance.

Form P: The polyurethane surface is vulcanised firmly to the ball. It is abrasion-resistant and does not discolour. Offers optimum protection against damage to delicate surfaces. The pearl-like surface gives a firm grip and allows air to escape so as to prevent any suction effect between the contact surface and the toggle locator.

**Advantages:**  
The built-in O-ring holds the ball in place and keeps dirt and foreign particles out, ensuring uniform movement. The hexagon socket allows easy adjustment and positioning in through holes.

# Self-aligning pads

adjustable, with o-ring and hexagon socket



## KIPP Self-aligning pads adjustable with O-ring and hexagon socket

Order No.	Form	D1	D2	L	SW1	Ball-Ø	Load rating max. kN (static load only)
K0290.112X025	C	M12	6	25	6	7	15
K0290.112X035	C	M12	6	35	6	7	15
K0290.112X050	C	M12	6	50	6	7	15
K0290.116X025	C	M16	8,5	25	8	10	23
K0290.116X035	C	M16	8,5	35	8	10	23
K0290.116X050	C	M16	8,5	50	8	10	23

Order No.	Form	D1	D2	L	SW1	Ball-Ø	Load rating max. kN (static load only)
K0290.312X025	F	M12	6	25	6	7	15
K0290.312X035	F	M12	6	35	6	7	15
K0290.312X050	F	M12	6	50	6	7	15
K0290.316X025	F	M16	8,5	25	8	10	23
K0290.316X035	F	M16	8,5	35	8	10	23
K0290.316X050	F	M16	8,5	50	8	10	23

Order No.	Form	D1	D2	L	SW1	Ball-Ø	Load rating max. kN (static load only)
K0290.712X025	K	M12	6	25	6	7	2
K0290.712X035	K	M12	6	35	6	7	2
K0290.712X050	K	M12	6	50	6	7	2
K0290.716X025	K	M16	8,5	25	8	10	4
K0290.716X035	K	M16	8,5	35	8	10	4
K0290.716X050	K	M16	8,5	50	8	10	4

Order No.	Form	D1	D2	L	L3	SW1	Ball-Ø	Load rating max. kN (static load only)
K0290.510X	O	M10	6	26,5/36,5/51,5	1,5	5	5	-
K0290.512X	O	M12	8	27/37/52	2	6	7	15,4
K0290.516X	O	M16	11	28/38/53	3	8	10	23,3
K0290.520X	O	M20	14	33/53/73	3	10	13	37,7

Order No.	Form	D1	D2	L	L3	SW1	Ball-Ø
K0290.610X	P	M10	8	28,5/38,5/53,5	3,5	5	5
K0290.612X	P	M12	10	29/39/54	4	6	7
K0290.616X	P	M16	13	30/40/55	5	8	10
K0290.620X	P	M20	16	35/55/75	5	10	13

## Self-aligning pads

adjustable, with o-ring, exchangeable inserts and hexagon socket



Form C  
steel insert, flat face

Form E  
stainless steel insert, flat face

Form K  
POM insert, flat face

Form F  
diamond grip insert

Form M  
carbide steel  
diamond grip

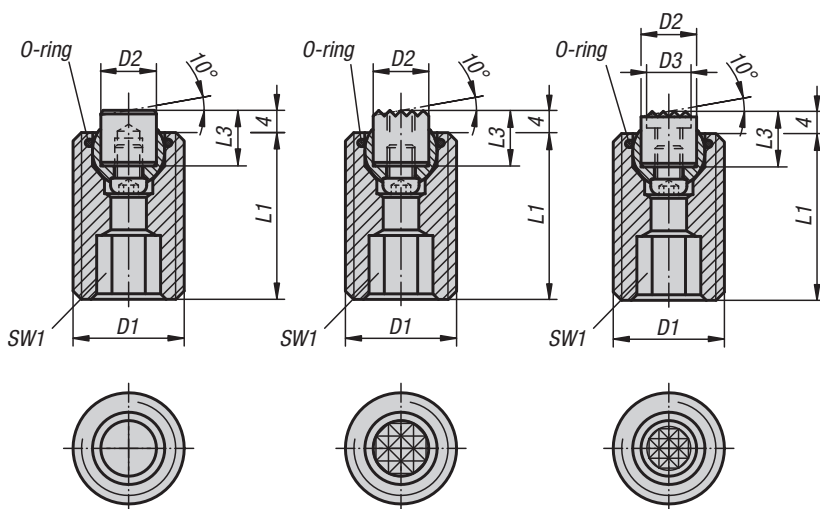

Form O  
stainless steel insert  
diamond impregnated

Form P  
stainless steel insert,  
PUR surface

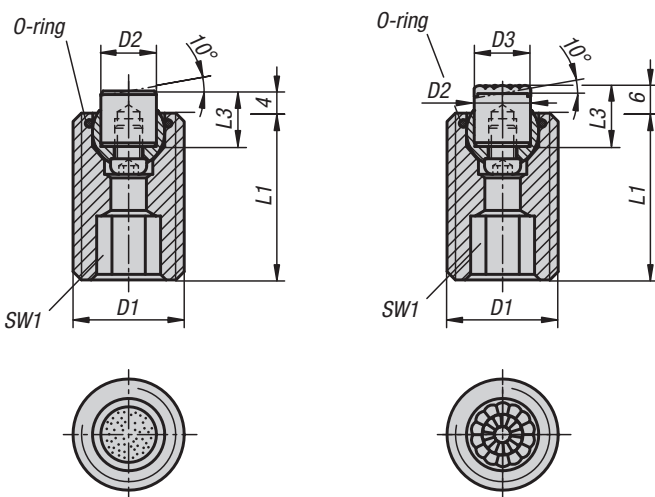

### Material:

Body carbon steel.  
Ball rust and acid resistant steel.  
Inserts:  
Form C, F, M tool steel  
Form K POM  
Form E stainless steel.  
Form O stainless steel diamond impregnated.  
Form P stainless steel with polyurethane surface.

### Version:

Body tempered, black oxidised.  
Ball hardened, bright.  
Inserts:  
Form C, F hardened, black oxidised.  
Form M with carbide serrations, black oxidised.  
Form K white.  
Form E hardened, bright.  
Form O diamond impregnated surface comparable to 100 grade abrasive grit.  
Form P polyurethane surface, hardness 60° Shore.

### Sample order:

K0291.720X070

### Note:

Self-aligning pads are used to support and clamp unmachined and machined workpieces. They also serve as stops, supports and thrust pads in fixtures and toolmaking. The ball can be removed from the housing by applying light pressure to the socket head screw.

Ball secured against rotation.

### Advantages:

Highly cost-effective as inserts can be exchanged. The built-in o-ring holds the ball in place and keeps dirt and foreign particles out, ensuring uniform movement.

## KIPP Self-aligning pads adjustable with o-ring, exchangeable inserts and hexagon socket

Order No.	Form	D1	D2	L1	L3	SW1	Ball-Ø	Load rating max. kN (static load only)	Order No. steel insert
K0291.120X030	C	M20	10	30	10	10	13	37	K0385.10108
K0291.120X050	C	M20	10	50	10	10	13	37	K0385.10108
K0291.120X070	C	M20	10	70	10	10	13	37	K0385.10108
K0291.124X040	C	M24	12	40	10	10	15	55	K0385.12108
K0291.124X080	C	M24	12	80	10	10	15	55	K0385.12108

# Self-aligning pads

adjustable, with o-ring, exchangeable inserts and hexagon socket

Order No.	Form	D1	D2	L1	L3	SW1	Ball-Ø	Load rating max. kN (static load only)	Order No. stainless steel insert
K0291.220X030	E	M20	10	30	10	10	13	37	K0385.10102
K0291.220X050	E	M20	10	50	10	10	13	37	K0385.10102
K0291.220X070	E	M20	10	70	10	10	13	37	K0385.10102
K0291.224X040	E	M24	12	40	10	10	15	55	K0385.12102
K0291.224X080	E	M24	12	80	10	10	15	55	K0385.12102

Order No.	Form	D1	D2	L1	L3	SW1	Ball-Ø	Load rating max. kN (static load only)	Order No. gripper
K0291.320X030	F	M20	10	30	10	10	13	37	K0385.1010
K0291.320X050	F	M20	10	50	10	10	13	37	K0385.1010
K0291.320X070	F	M20	10	70	10	10	13	37	K0385.1010
K0291.324X040	F	M24	12	40	10	10	15	55	K0385.1210
K0291.324X080	F	M24	12	80	10	10	15	55	K0385.1210

Order No.	Form	D1	D2	L1	L3	SW1	Ball-Ø	Load rating max. kN (static load only)	Order No. POM insert
K0291.720X030	K	M20	10	30	10	10	13	4	K0385.10109
K0291.720X050	K	M20	10	50	10	10	13	4	K0385.10109
K0291.720X070	K	M20	10	70	10	10	13	4	K0385.10109
K0291.724X040	K	M24	12	40	10	10	15	7	K0385.12109
K0291.724X080	K	M24	12	80	10	10	15	7	K0385.12109

Order No.	Form	D1	D2	D3	L1	L3	SW1	Ball-Ø	Load rating max. kN (static load only)	Order No. gripper
K0291.920X030	M	M20	10	7,9	30	10	10	13	37	K0385.10107
K0291.920X050	M	M20	10	7,9	50	10	10	13	37	K0385.10107
K0291.920X070	M	M20	10	7,9	70	10	10	13	37	K0385.10107
K0291.924X040	M	M24	12	9,5	40	10	10	15	55	K0385.12107
K0291.924X080	M	M24	12	9,5	80	10	10	15	55	K0385.12107

Order No.	Form	D1	D2	L1	L3	SW1	Ball-Ø	Load rating max. kN (static load only)	Order No. stainless steel insert, diamond surface
K0291.520X030	O	M20	10	30	10	10	13	37	K0385.10105
K0291.520X050	O	M20	10	50	10	10	13	37	K0385.10105
K0291.520X070	O	M20	10	70	10	10	13	37	K0385.10105
K0291.524X040	O	M24	12	40	10	10	15	55	K0385.12105
K0291.524X080	O	M24	12	80	10	10	15	55	K0385.12105

Order No.	Form	D1	D2	D3	L1	L3	SW1	Ball-Ø	Load rating max. kN (static load only)	Order No. stainless steel insert, polyurethane surface
K0291.620X030	P	M20	10	10	30	12	10	13	37	K0385.10126
K0291.620X050	P	M20	10	10	50	12	10	13	37	K0385.10126
K0291.620X070	P	M20	10	10	70	12	10	13	37	K0385.10126
K0291.624X040	P	M24	12	13	40	12	10	15	55	K0385.12126
K0291.624X080	P	M24	12	13	80	12	10	15	55	K0385.12126

## Ball-end thrust screws with head



Form A  
full ball

Form B  
flattened ball

Form F  
flattened ball  
diamond grip

Form BV  
flattened ball  
non-rotating

Form FV  
flattened ball  
diamond grip  
non-rotating

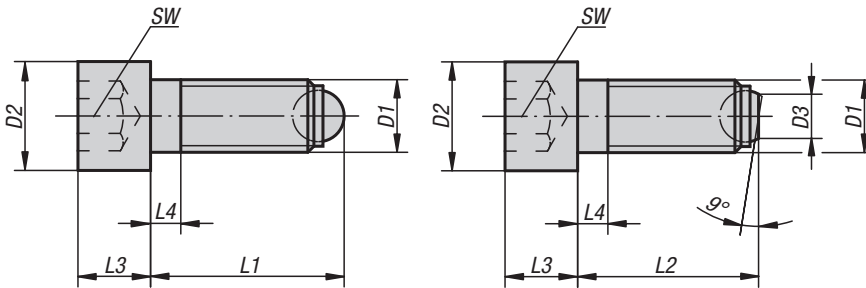

**Material:**

Screw carbon steel.  
Ball ball-bearing steel.

**Version:**

Screw, grade 10.9, black.  
Ball hardened, bright.

**Sample order:**

K0380.10820

**Note:**

Form A with full ball is used when a clean, polished contact surface is required. Surfaces which are not flat and parallel can be firmly clamped or supported with Form B with flattened ball, the movable ball can adapt itself up to 9°.

### KIPP Ball-end thrust screws with head

Order No.	Form	D1	L1	D2	L3	L4	Ball-Ø	SW	Load rating max. kN (static load only)
K0380.10410	A	M4	10,2	7	4	2,1	2,5	3	3,5
K0380.10416	A	M4	16,2	7	4	2,1	2,5	3	3,5
K0380.10420	A	M4	20,2	7	4	2,1	2,5	3	3,5
K0380.10512	A	M5	12,4	8,5	5	2,4	3	4	4,5
K0380.10516	A	M5	16,4	8,5	5	2,4	3	4	4,5
K0380.10520	A	M5	20,4	8,5	5	2,4	3	4	4,5
K0380.10620	A	M6	20,8	10	6	3	4	5	9
K0380.10630	A	M6	30,8	10	6	3	4	5	9
K0380.10640	A	M6	40,8	10	6	16	4	5	9
K0380.10820	A	M8	21,2	13	8	3,5	5,5	6	15
K0380.10835	A	M8	36,2	13	8	3,5	5,5	6	15
K0380.10850	A	M8	51,2	13	8	22	5,5	6	15
K0380.11025	A	M10	26,7	16	10	4,5	7	8	20
K0380.11040	A	M10	41,7	16	10	4,5	7	8	20
K0380.11060	A	M10	61,7	16	10	28	7	8	20
K0380.11230	A	M12	32	18	12	5	8,5	10	30
K0380.11250	A	M12	52	18	12	5	8,5	10	30
K0380.11280	A	M12	82	18	12	44	8,5	10	30
K0380.11640	A	M16	43,3	24	16	6	12	14	60
K0380.11660	A	M16	63,3	24	16	6	12	14	60
K0380.11680	A	M16	83,3	24	16	36	12	14	60
K0380.120100	A	M20	104,2	30	20	48	15	17	90
K0380.12050	A	M20	54,2	30	20	7,5	15	17	90
K0380.12080	A	M20	84,2	30	20	28	15	17	90
K0380.124120	A	M24	124,7	36	24	60	18	19	120
K0380.12460	A	M24	64,7	36	24	9	18	19	120
K0380.12490	A	M24	94,7	36	24	30	18	19	120

## Ball-end thrust screws with head

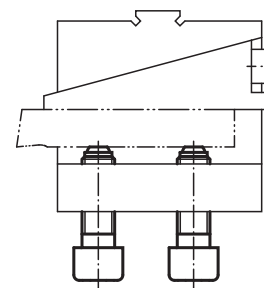

Order No. Form B	Order No. Form F	D1	D2	D3	L2	L3	L4	Ball-Ø	SW	Load rating max. kN (static load only)
K0380.20410	-	M4	7	1,4	10	4	2,1	2,5	3	3,5
K0380.20416	-	M4	7	1,4	16	4	2,1	2,5	3	3,5
K0380.20420	-	M4	7	1,4	20	4	2,1	2,5	3	3,5
K0380.20512	-	M5	8,5	2	12	5	2,4	3	4	4,5
K0380.20516	-	M5	8,5	2	16	5	2,4	3	4	4,5
K0380.20520	-	M5	8,5	2	20	5	2,4	3	4	4,5
K0380.20620	-	M6	10	3,2	20	6	3	4	5	9
K0380.20630	-	M6	10	3,2	30	6	3	4	5	9
K0380.20640	-	M6	10	3,2	40	6	16	4	5	9
K0380.20820	-	M8	13	4,5	20	8	3,5	5,5	6	15
K0380.20835	-	M8	13	4,5	35	8	3,5	5,5	6	15
K0380.20850	-	M8	13	4,5	50	8	22	5,5	6	15
K0380.21025	K0380.31025	M10	16	6	25	10	4,5	7	8	20
K0380.21040	K0380.31040	M10	16	6	40	10	4,5	7	8	20
K0380.21060	K0380.31060	M10	16	6	60	10	28	7	8	20
K0380.21230	K0380.31230	M12	18	7,2	30	12	5	8,5	10	30
K0380.21250	K0380.31250	M12	18	7,2	50	12	5	8,5	10	30
K0380.21280	K0380.31280	M12	18	7,2	80	12	44	8,5	10	30
K0380.21640	K0380.31640	M16	24	10,7	40	16	6	12	14	60
K0380.21660	K0380.31660	M16	24	10,7	60	16	6	12	14	60
K0380.21680	K0380.31680	M16	24	10,7	80	16	36	12	14	60
K0380.220100	-	M20	30	13,5	100	20	48	15	17	90
K0380.22050	-	M20	30	13,5	50	20	7,5	15	17	90
K0380.22080	-	M20	30	13,5	80	20	28	15	17	90
K0380.224120	-	M24	36	15,8	120	24	60	18	19	120
K0380.22460	-	M24	36	15,8	60	24	9	18	19	120
K0380.22490	-	M24	36	15,8	90	24	30	18	19	120

Order No. Form BV	Order No. Form FV	D1	D2	D3	L2	L3	L4	Ball-Ø	SW	Load rating max. kN (static load only)
K0380.40820	-	M8	13	4,5	20	8	3,5	5,5	6	9
K0380.40835	-	M8	13	4,5	35	8	3,5	5,5	6	9
K0380.40850	-	M8	13	4,5	50	8	22	5,5	6	9
K0380.41025	K0380.51025	M10	16	6	25	10	4,5	7	8	12
K0380.41040	K0380.51040	M10	16	6	40	10	4,5	7	8	12
K0380.41060	K0380.51060	M10	16	6	60	10	28	7	8	12
K0380.41230	K0380.51230	M12	18	7,2	30	12	5	8,5	10	18
K0380.41250	K0380.51250	M12	18	7,2	50	12	5	8,5	10	18
K0380.41280	K0380.51280	M12	18	7,2	80	12	44	8,5	10	18
K0380.41640	K0380.51640	M16	24	10,7	40	16	6	12	14	36
K0380.41660	K0380.51660	M16	24	10,7	60	16	6	12	14	36
K0380.41680	K0380.51680	M16	24	10,7	80	16	36	12	14	36

## Ball-end thrust screws with head

stainless steel

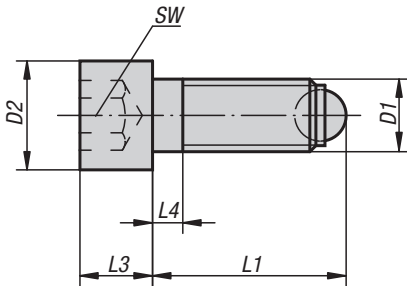

Form A  
with full ball

**Material:**  
Stainless steel

**Version:**  
Bright.

**Sample order:**  
K0381.11230

**Note:**

Form A with full ball is used when a clean, polished contact surface is required. Surfaces which are not flat and parallel can be firmly clamped or supported with Form B with flattened ball, the movable ball can adapt itself up to 9°.

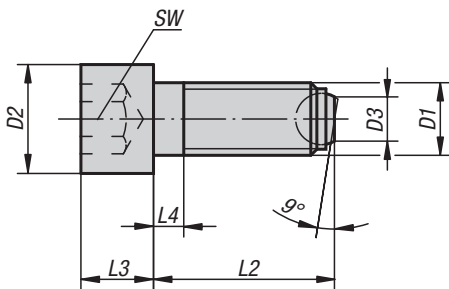

Form B  
with flattened ball

### KIPP Ball-end thrust screws with head, stainless steel

Order No. Form A	Order No. Form B	D1	D2	L1	L3	L4	Ball-Ø	SW
K0381.10410	K0381.20410	M4	7	10,2/-	4	2,1	2,5	3
K0381.10416	K0381.20416	M4	7	16,2/-	4	2,1	2,5	3
K0381.10420	K0381.20420	M4	7	20,2/-	4	2,1	2,5	3
K0381.10512	K0381.20512	M5	8,5	12,4/-	5	2,4	3	4
K0381.10516	K0381.20516	M5	8,5	16,4/-	5	2,4	3	4
K0381.10520	K0381.20520	M5	8,5	20,4/-	5	2,4	3	4
K0381.10620	K0381.20620	M6	10	20,8/-	6	3	4	5
K0381.10630	K0381.20630	M6	10	30,8/-	6	3	4	5
K0381.10640	K0381.20640	M6	10	40,8/-	6	16	4	5
K0381.10820	K0381.20820	M8	13	21,2/-	8	3,5	5,5	6
K0381.10835	K0381.20835	M8	13	36,2/-	8	3,5	5,5	6
K0381.10850	K0381.20850	M8	13	51,2/-	8	22	5,5	6
K0381.11025	K0381.21025	M10	16	26,7/-	10	4,5	7	8
K0381.11040	K0381.21040	M10	16	41,7/-	10	4,5	7	8
K0381.11060	K0381.21060	M10	16	61,7/-	10	28	7	8
K0381.11230	K0381.21230	M12	18	32/-	12	5	8,5	10
K0381.11250	K0381.21250	M12	18	52/-	12	5	8,5	10
K0381.11280	K0381.21280	M12	18	82/-	12	44	8,5	10
K0381.11640	K0381.21640	M16	24	43,3/-	16	6	12	14
K0381.11660	K0381.21660	M16	24	63,3/-	16	6	12	14
K0381.11680	K0381.21680	M16	24	83,3/-	16	36	12	14



## Ball-end thrust screws without head

with fine thread



Form A  
with full ball

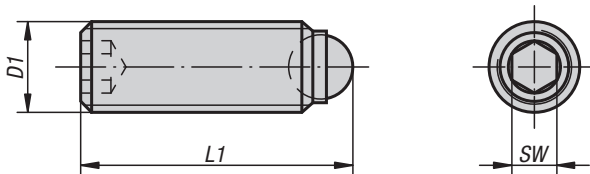

Form B  
with flattened ball

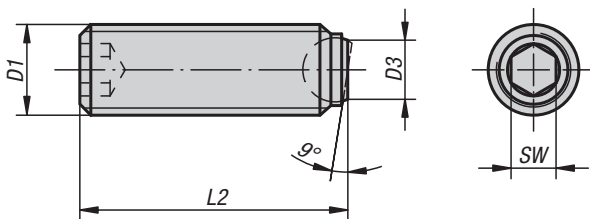

**Material:**

Screw carbon steel, grade 10.9  
Ball, ball-bearing steel.

**Version:**

Screw black.  
Ball hardened and bright.

**Sample order:**

K0382.11025

**Note:**

Form A with full ball is used when a clean, polished pressure surface is required. Surfaces which are not plane and parallel can be firmly clamped or supported with Form B with flattened ball because the movable ball can adapt itself up to 9°.

Fine thread enables extremely sensitive alignment of the ball-end thrust screws.

### KIPP Ball-end thrust screws without head with fine thread

Order No. Form A	Order No. Form B	D1	D3	L1	L2	Ball-Ø	SW	Load rating max. kN (static load only)
K0382.10810	K0382.20810	M8x1	-/4,1	11,2/-	-/10,3	5,5	4	10
K0382.10820	K0382.20820	M8x1	-/4,1	21,2/-	-/20,3	5,5	4	15
K0382.11012	K0382.21012	M10x1	-/5,6	13,7/-	-/12,3	7	5	20
K0382.11025	K0382.21025	M10x1	-/5,6	26,7/-	-/25,3	7	5	20
K0382.11216	K0382.21216	M12x1,5	-/7	18/-	-/16,2	8,5	6	30
K0382.11230	K0382.21230	M12x1,5	-/7	32/-	-/30,2	8,5	6	30
K0382.11620	K0382.21620	M16x1,5	-/10,7	23,3/-	-/20	12	8	60
K0382.11635	K0382.21635	M16x1,5	-/10,7	38,3/-	-/35	12	8	60
K0382.12030	K0382.22030	M20x1,5	-/13,5	34,2/-	-/30	15	10	90
K0382.12040	K0382.22040	M20x1,5	-/13,5	44,2/-	-/40	15	10	90



## Ball-end thrust screws without head

with full ball



Form A  
steel ball

Form D  
POM ball

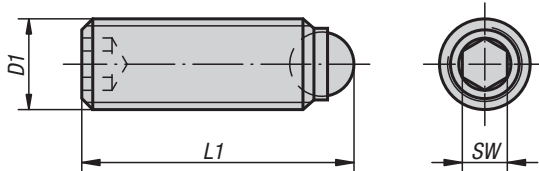

**Material:**

Screw carbon steel, grade 10.9  
Ball, ball-bearing steel or POM.

**Version:**

Screw black.  
Ball hardened bright or POM.

**Sample order:**

K0383.10810

**Note:**

Ball-end thrust screws with full ball are used when a clean, polished contact surface is required. Longer versions have been specially designed to be glued in, allowing mechanical connecting elements with external thread to be made cost-effectively for small and medium-sized series.

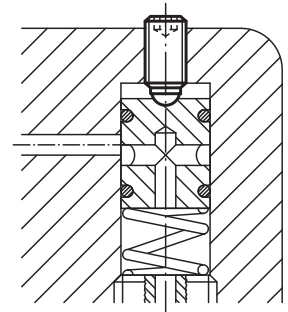

### KIPP Ball-end thrust screws without head with full ball

Order No. Form A	Order No. Form D	D1	L1	Ball-Ø	SW	Load rating max. kN (static load only)
K0383.1046	K0383.3046	M4	6	2,5	2	3,5/0,3
K0383.1048	K0383.3048	M4	8	2,5	2	3,5/0,3
K0383.10410	K0383.30410	M4	10	2,5	2	3,5/0,3
K0383.10412	K0383.30412	M4	12	2,5	2	3,5/0,3
K0383.10416	K0383.30416	M4	16	2,5	2	3,5/0,3
K0383.1058	K0383.3058	M5	8	3	2,5	4,5/0,5
K0383.10510	K0383.30510	M5	10	3	2,5	4,5/0,5
K0383.10512	K0383.30512	M5	12	3	2,5	4,5/0,5
K0383.10516	K0383.30516	M5	16	3	2,5	4,5/0,5
K0383.10520	K0383.30520	M5	20	3	2,5	4,5/0,5
K0383.10525	K0383.30525	M5	25	3	2,5	4,5/0,5
K0383.10610	K0383.30610	M6	10,8	4	3	9/0,9
K0383.10612	K0383.30612	M6	12,8	4	3	9/0,9
K0383.10616	K0383.30616	M6	16,8	4	3	9/0,9
K0383.10620	K0383.30620	M6	20,8	4	3	9/0,9
K0383.10625	K0383.30625	M6	25,8	4	3	9/0,9
K0383.10650	-	M6	50,8	4	3	9
K0383.10660	-	M6	60,8	4	3	9
K0383.10680	-	M6	80,8	4	3	9

# Ball-end thrust screws without head

with full ball

## KIPP Ball-end thrust screws without head with full ball

Order No. Form A	Order No. Form D	D1	L1	Ball-Ø	SW	Load rating max. kN (static load only)
K0383.10810	K0383.30810	M8	11,2	5,5	4	10/1,5
K0383.10812	K0383.30812	M8	13,2	5,5	4	10/1,5
K0383.10816	K0383.30816	M8	17,2	5,5	4	15/1,5
K0383.10820	K0383.30820	M8	21,2	5,5	4	15/1,5
K0383.10825	K0383.30825	M8	26,2	5,5	4	15/1,5
K0383.10830	K0383.30830	M8	31,2	5,5	4	15/1,5
K0383.10850	-	M8	51,2	5,5	4	15
K0383.10860	-	M8	61,2	5,5	4	15
K0383.10880	-	M8	81,2	5,5	4	15
K0383.11012	K0383.31012	M10	13,7	7	5	20/2
K0383.11016	K0383.31016	M10	17,7	7	5	20/2
K0383.11020	K0383.31020	M10	21,7	7	5	20/2
K0383.11025	K0383.31025	M10	26,7	7	5	20/2
K0383.11035	K0383.31035	M10	36,7	7	5	20/2
K0383.11216	K0383.31216	M12	18	8,5	6	30/3
K0383.11220	K0383.31220	M12	22	8,5	6	30/3
K0383.11225	-	M12	27	8,5	6	30
K0383.11230	K0383.31230	M12	32	8,5	6	30/3
K0383.11232	-	M12	34	8,5	6	30
K0383.11240	K0383.31240	M12	42	8,5	6	30/3
K0383.11620	-	M16	23,3	12	8	60
K0383.11625	-	M16	28,3	12	8	60
K0383.11635	-	M16	38,3	12	8	60
K0383.11650	-	M16	53,3	12	8	60
K0383.12030	-	M20	34,2	15	10	90
K0383.12040	-	M20	44,2	15	10	90
K0383.12060	-	M20	64,2	15	10	90
K0383.12435	-	M24	39,7	18	12	120
K0383.12450	-	M24	54,7	18	12	120
K0383.12480	-	M24	84,7	18	12	120



# Ball-end thrust screws without head

stainless steel with full ball



Form A  
ball stainless steel

Form D  
ball POM

Form E  
ball ceramic

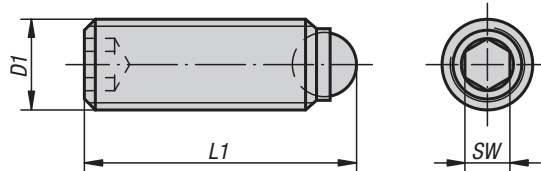

**Material:**

Screw stainless steel.  
Ball stainless steel, POM or ceramic  $\text{Si}_3\text{N}_4$ .

**Version:**

Stainless steel bright.

**Sample order:**

K0384.1046

**Note:**

Ball-end thrust screws with full ball are used when a clean, polished contact surface is required. Longer versions have been designed especially to be glued in, allowing mechanical connecting elements with external threads to be made cost-effectively for small and medium-sized runs. Silicon nitride ( $\text{Si}_3\text{N}_4$ ) is characterised by a combination of excellent properties, these include high resilience and strength, excellent wear resistance and good chemical resistance.

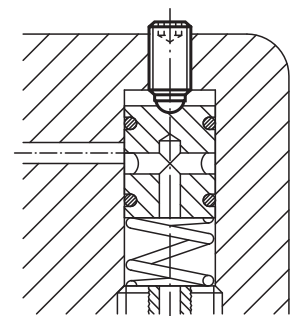

# Ball-end thrust screws without head

stainless steel with full ball

## KIPP Ball-end thrust screws without head, stainless steel, with full ball

Order No. Form A	Order No. Form D	Order No. Form E	D1	L1	Ball-Ø	SW
K0384.1046	K0384.3046	-	M4	6	2,5	2
K0384.1048	K0384.3048	-	M4	8	2,5	2
K0384.10410	K0384.30410	-	M4	10	2,5	2
K0384.10412	K0384.30412	-	M4	12	2,5	2
K0384.10416	K0384.30416	-	M4	16	2,5	2
K0384.1058	K0384.3058	K0384.8058	M5	8	3	2,5
K0384.10510	K0384.30510	-	M5	10	3	2,5
K0384.10512	K0384.30512	K0384.80512	M5	12	3	2,5
K0384.10516	K0384.30516	-	M5	16	3	2,5
K0384.10520	K0384.30520	K0384.80520	M5	20	3	2,5
K0384.10525	K0384.30525	-	M5	25	3	2,5
K0384.10610	K0384.30610	K0384.80610	M6	10,8	4	3
K0384.10612	K0384.30612	-	M6	12,8	4	3
K0384.10616	K0384.30616	K0384.80616	M6	16,8	4	3
K0384.10620	K0384.30620	K0384.80620	M6	20,8	4	3
K0384.10625	K0384.30625	K0384.80625	M6	25,8	4	3
K0384.10650	-	-	M6	50,8	4	3
K0384.10660	-	-	M6	60,8	4	3
K0384.10680	-	-	M6	80,8	4	3
K0384.10810	K0384.30810	K0384.80810	M8	11,2	5,5	4
K0384.10812	K0384.30812	K0384.80812	M8	13,2	5,5	4
K0384.10816	K0384.30816	-	M8	17,2	5,5	4
K0384.10820	K0384.30820	K0384.80820	M8	21,2	5,5	4
K0384.10825	K0384.30825	K0384.80825	M8	26,2	5,5	4
K0384.10830	K0384.30830	K0384.80830	M8	31,2	5,5	4
K0384.10850	-	-	M8	51,2	5,5	4
K0384.10860	-	-	M8	61,2	5,5	4
K0384.10880	-	-	M8	81,2	5,5	4
K0384.11012	-	K0384.81012	M10	13,7	7	5
K0384.11016	-	K0384.81016	M10	17,7	7	5
K0384.11020	-	K0384.81020	M10	21,7	7	5
K0384.11025	-	K0384.81025	M10	26,7	7	5
K0384.11035	-	K0384.81035	M10	36,7	7	5
K0384.11216	-	K0384.81216	M12	18	8,5	6
K0384.11220	-	K0384.81220	M12	22	8,5	6
K0384.11225	-	-	M12	27	8,5	6
K0384.11230	-	K0384.81230	M12	32	8,5	6
K0384.11232	-	-	M12	34	8,5	6
K0384.11240	-	K0384.81240	M12	42	8,5	6
K0384.11620	-	-	M16	23,3	12	8
K0384.11625	-	-	M16	28,3	12	8
K0384.11635	-	-	M16	38,3	12	8
K0384.11650	-	-	M16	53,3	12	8



## Ball-end thrust screws without head

with flattened ball

Form B  
steel ball

Form C  
POM ball

Form F  
serrated steel ball

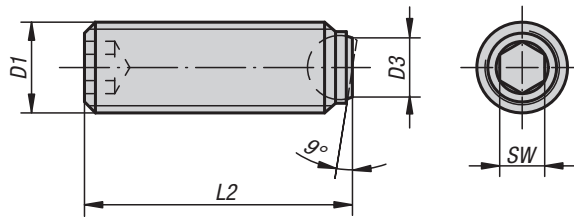

### Material:

Screw carbon steel, grade 10.9  
Ball, ball-bearing steel or POM.

### Version:

Screw black.  
Ball hardened bright or POM.

### Sample order:

K0383.41012

### Note:

Surfaces which are not flat and parallel can be firmly clamped or supported with Form B, C or F with flattened ball, the movable ball can adapt itself up to 9°. Longer versions have been specially designed to glue in, allowing mechanical connecting elements with external thread to be made cost-effectively for small and medium-sized series.

### KIPP Ball-end thrust screws without head with flattened POM ball

Order No.	Form	D1	D3	L2	Ball-Ø	SW	Load rating max. kN (static load only)
K0383.7046	C	M4	1,8	5,9	2,5	2	0,3
K0383.7048	C	M4	1,8	7,9	2,5	2	0,3
K0383.70410	C	M4	1,8	9,9	2,5	2	0,3
K0383.70412	C	M4	1,8	11,9	2,5	2	0,3
K0383.70416	C	M4	1,8	15,9	2,5	2	0,3
K0383.7058	C	M5	2,1	7,8	3	2,5	0,5
K0383.70510	C	M5	2,1	9,8	3	2,5	0,5
K0383.70512	C	M5	2,1	11,8	3	2,5	0,5
K0383.70516	C	M5	2,1	15,8	3	2,5	0,5
K0383.70520	C	M5	2,1	19,8	3	2,5	0,5
K0383.70525	C	M5	2,1	24,8	3	2,5	0,5
K0383.70610	C	M6	3	10,3	4	3	0,9
K0383.70612	C	M6	3	12,3	4	3	0,9
K0383.70616	C	M6	3	16,3	4	3	0,9
K0383.70620	C	M6	3	20,3	4	3	0,9
K0383.70625	C	M6	3	25,3	4	3	0,9
K0383.70810	C	M8	4,2	10,4	5,5	4	1,5
K0383.70812	C	M8	4,2	12,4	5,5	4	1,5
K0383.70816	C	M8	4,2	16,4	5,5	4	1,5
K0383.70820	C	M8	4,2	20,4	5,5	4	1,5
K0383.70825	C	M8	4,2	25,4	5,5	4	1,5
K0383.70830	C	M8	4,2	30,4	5,5	4	1,5

### KIPP Ball-end thrust screws without head with flattened serrated steel ball

Order No.	Form	D1	D3	L2	Ball-Ø	SW	Load rating max. kN (static load only)
K0383.41012	F	M10	6	12	7	5	20
K0383.41016	F	M10	6	16	7	5	20
K0383.41025	F	M10	6	25	7	5	20
K0383.41035	F	M10	6	35	7	5	20
K0383.41216	F	M12	7,2	16	8,5	6	30
K0383.41220	F	M12	7,2	20	8,5	6	30
K0383.41230	F	M12	7,2	30	8,5	6	30
K0383.41240	F	M12	7,2	40	8,5	6	30
K0383.41620	F	M16	10,7	20	12	8	60
K0383.41625	F	M16	10,7	25	12	8	60
K0383.41635	F	M16	10,7	35	12	8	60
K0383.41650	F	M16	10,7	50	12	8	60

# Ball-end thrust screws without head

with flattened ball

## KIPP Ball-end thrust screws without head with flattened steel ball

Order No.	Form	D1	D3	L2	Ball-Ø	SW	Load rating max. kN (static load only)
K0383.2046	B	M4	1,4	5,8	2,5	2	3,5
K0383.2048	B	M4	1,4	7,8	2,5	2	3,5
K0383.20410	B	M4	1,4	9,8	2,5	2	3,5
K0383.20412	B	M4	1,4	11,8	2,5	2	3,5
K0383.20416	B	M4	1,4	15,8	2,5	2	3,5
K0383.2058	B	M5	2	7,6	3	2,5	4,5
K0383.20510	B	M5	2	9,6	3	2,5	4,5
K0383.20512	B	M5	2	11,6	3	2,5	4,5
K0383.20516	B	M5	2	15,6	3	2,5	4,5
K0383.20520	B	M5	2	19,6	3	2,5	4,5
K0383.20525	B	M5	2	24,6	3	2,5	4,5
K0383.20610	B	M6	3	10,1	4	3	9
K0383.20612	B	M6	3	12,1	4	3	9
K0383.20616	B	M6	3	16,1	4	3	9
K0383.20620	B	M6	3	20,1	4	3	9
K0383.20625	B	M6	3	25,1	4	3	9
K0383.20650	B	M6	3	50,1	4	3	9
K0383.20660	B	M6	3	60,1	4	3	9
K0383.20680	B	M6	3	80,1	4	3	9
K0383.20810	B	M8	4,1	10,3	5,5	4	10
K0383.20812	B	M8	4,1	12,3	5,5	4	10
K0383.20816	B	M8	4,1	16,3	5,5	4	15
K0383.20820	B	M8	4,1	20,3	5,5	4	15
K0383.20825	B	M8	4,1	25,3	5,5	4	15
K0383.20830	B	M8	4,1	30,3	5,5	4	15
K0383.20850	B	M8	4,1	50,3	5,5	4	15
K0383.20860	B	M8	4,1	60,3	5,5	4	15
K0383.20880	B	M8	4,1	80,3	5,5	4	15
K0383.21012	B	M10	5,6	12,3	7	5	20
K0383.21016	B	M10	5,6	16,3	7	5	20
K0383.21020	B	M10	5,6	20,3	7	5	20
K0383.21025	B	M10	5,6	25,3	7	5	20
K0383.21035	B	M10	5,6	35,3	7	5	20
K0383.21216	B	M12	7	16,2	8,5	6	30
K0383.21220	B	M12	7	20,2	8,5	6	30
K0383.21230	B	M12	7	30,2	8,5	6	30
K0383.21240	B	M12	7	40,2	8,5	6	30
K0383.21620	B	M16	10,7	20	12	8	60
K0383.21625	B	M16	10,7	25	12	8	60
K0383.21635	B	M16	10,7	35	12	8	60
K0383.21650	B	M16	10,7	50	12	8	60
K0383.22030	B	M20	13,5	30	15	10	90
K0383.22040	B	M20	13,5	40	15	10	90
K0383.22060	B	M20	13,5	60	15	10	90
K0383.22435	B	M24	15,8	35	18	12	120
K0383.22450	B	M24	15,8	50	18	12	120
K0383.22480	B	M24	15,8	80	18	12	120



# Ball-end thrust screws without head

stainless steel with flattened ball

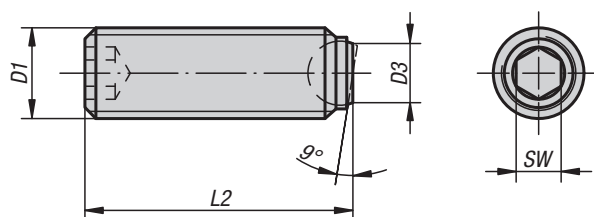

## KIPP Ball-end thrust screws without head, stainless steel with flattened ball

Order No.	D1	D3	L2	Ball-Ø	SW
K0384.2046	M4	1,4	5,8	2,5	2
K0384.2048	M4	1,4	7,8	2,5	2
K0384.20410	M4	1,4	9,8	2,5	2
K0384.20412	M4	1,4	11,8	2,5	2
K0384.20416	M4	1,4	15,8	2,5	2
K0384.2058	M5	2	7,6	3	2,5
K0384.20510	M5	2	9,6	3	2,5
K0384.20512	M5	2	11,6	3	2,5
K0384.20516	M5	2	15,6	3	2,5
K0384.20520	M5	2	19,6	3	2,5
K0384.20525	M5	2	24,6	3	2,5
K0384.20610	M6	3	10,1	4	3
K0384.20612	M6	3	12,1	4	3
K0384.20616	M6	3	16,1	4	3
K0384.20620	M6	3	20,1	4	3
K0384.20625	M6	3	25,1	4	3
K0384.20650	M6	3	50,1	4	3
K0384.20660	M6	3	60,1	4	3
K0384.20680	M6	3	80,1	4	3
K0384.20810	M8	4,1	10,3	5,5	4
K0384.20812	M8	4,1	12,3	5,5	4
K0384.20816	M8	4,1	16,3	5,5	4
K0384.20820	M8	4,1	20,3	5,5	4
K0384.20825	M8	4,1	25,3	5,5	4
K0384.20830	M8	4,1	30,3	5,5	4
K0384.20850	M8	4,1	50,3	5,5	4
K0384.20860	M8	4,1	60,3	5,5	4
K0384.20880	M8	4,1	80,3	5,5	4
K0384.21012	M10	5,6	12,3	7	5
K0384.21016	M10	5,6	16,3	7	5
K0384.21020	M10	5,6	20,3	7	5
K0384.21025	M10	5,6	25,3	7	5
K0384.21035	M10	5,6	35,3	7	5
K0384.21216	M12	7	16,2	8,5	6
K0384.21220	M12	7	20,2	8,5	6
K0384.21230	M12	7	30,2	8,5	6
K0384.21240	M12	7	40,2	8,5	6
K0384.21620	M16	10,7	20	12	8
K0384.21625	M16	10,7	25	12	8
K0384.21635	M16	10,7	35	12	8
K0384.21650	M16	10,7	50	12	8

### Material:

Screw and ball stainless steel.

### Version:

Stainless steel bright.

### Sample order:

K0384.2046

### Note:

Surfaces which are not flat and parallel can be firmly clamped or supported with with a flattened ball, the movable ball can adapt itself up to 9°.

Longer versions have been designed especially to be glued in. This allows mechanical connecting elements with external thread to be made cost-effectively for small and medium-sized series.



## Ball-end thrust screws without head

with flattened ball and rotation lock



Form BV  
flattened ball  
non-rotating

Form FV  
flattened ball  
diamond grip, non-rotating

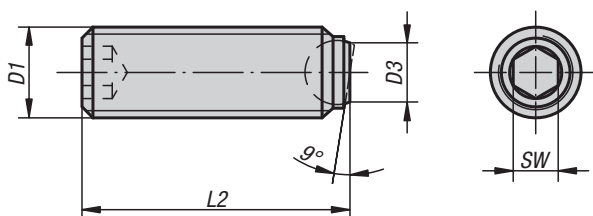

**Material:**

Screw carbon steel, grade 10.9  
Ball, ball-bearing steel.

**Version:**

Screw black.  
Ball hardened, bright.

**Sample order:**

K0383.50820

**Note:**

Surfaces which are not flat and parallel can be firmly clamped or supported with with a flattened ball, the movable ball can adapt itself up to 9°.  
Longer versions have been designed especially to be glued in. This allows mechanical connecting elements with external thread to be made cost-effectively for small and medium-sized series.



### KIPP Ball-end thrust screws without head, with flattened ball and rotation lock

Order No. Form BV	Order No. Form FV	D1	D3	L2	Ball-Ø	SW	Load rating max. kN (static load only)
K0383.50820	-	M8	4,1	20,3	5,5	4	9
K0383.50830	-	M8	4,1	30,3	5,5	4	9
K0383.51025	K0383.61025	M10	5,6	25,3	7	5	12
K0383.51035	K0383.61035	M10	5,6	35,3	7	5	12
K0383.51230	K0383.61230	M12	7	30,2	8,5	6	18
K0383.51240	K0383.61240	M12	7	40,2	8,5	6	18
K0383.51635	K0383.61635	M16	10,7	35	12	8	36
K0383.51650	K0383.61650	M16	10,7	50	12	8	36

## Ball-end thrust screws without head

with full ball, LONG-LOK secured



Form A  
ball steel

Form D  
ball POM

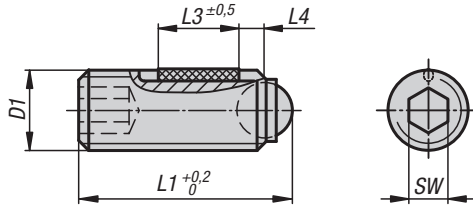

L4 = approx. two thread turns

**Material:**

Screw carbon steel, grade 10.9  
Ball, ball-bearing steel or POM.  
LONG-LOK thread lock nylon.

**Version:**

Screw black.  
Ball hardened, bright.

**Sample order:**

K0666.1046

**Note:**

Ball-end thrust screws with full ball are used when a clean, polished contact surface is required.

### KIPP Ball-end thrust screws without head, with full ball, LONG-LOK secured

Order No. Form A	Order No. Form D	D1	L1	L3	Ball-Ø	SW	Load rating max. kN (static load only)
K0666.1046	K0666.3046	M4	6	2,5	2,5	2	3,5/0,3
K0666.10410	K0666.30410	M4	10	3,5	2,5	2	3,5/0,3
K0666.10416	K0666.30416	M4	16	5	2,5	2	3,5/0,3
K0666.1058	K0666.3058	M5	8	3,5	3	2,5	4,5/0,5
K0666.10512	K0666.30512	M5	12	5	3	2,5	4,5/0,5
K0666.10520	K0666.30520	M5	20	6	3	2,5	4,5/0,5
K0666.10610	K0666.30610	M6	10,8	3,5	4	3	9/0,9
K0666.10616	K0666.30616	M6	16,8	7	4	3	9/0,9
K0666.10620	K0666.30620	M6	20,8	7	4	3	9/0,9
K0666.10625	K0666.30625	M6	25,8	7	4	3	9/0,9
K0666.10650	-	M6	50,8	7	4	3	9
K0666.10660	-	M6	60,8	7	4	3	9
K0666.10810	K0666.30810	M8	11,2	3,5	5,5	4	10/1,5
K0666.10812	K0666.30812	M8	13,2	5	5,5	4	10/1,5
K0666.10820	K0666.30820	M8	21,2	8	5,5	4	15/1,5
K0666.10825	K0666.30825	M8	26,2	8	5,5	4	15/1,5
K0666.10830	K0666.30830	M8	31,2	8	5,5	4	15/1,5
K0666.10850	-	M8	51,2	8	5,5	4	15
K0666.10860	-	M8	61,2	8	5,5	4	15
K0666.10880	-	M8	81,2	8	5,5	4	15
K0666.11012	K0666.31012	M10	13,7	5	7	5	20/2
K0666.11016	K0666.31016	M10	17,7	9	7	5	20/2
K0666.11020	K0666.31020	M10	21,7	9	7	5	20/2
K0666.11025	K0666.31025	M10	26,7	9	7	5	20/2
K0666.11035	K0666.31035	M10	36,7	9	7	5	20/2
K0666.11216	K0666.31216	M12	18	8	8,5	6	30/3
K0666.11220	K0666.31220	M12	22	10	8,5	6	30/3
K0666.11230	K0666.31230	M12	32	10	8,5	6	30/3
K0666.11240	K0666.31240	M12	42	10	8,5	6	30/3
K0666.11620	-	M16	23,3	10	12	8	60
K0666.11625	-	M16	28,3	14	12	8	60
K0666.11635	-	M16	38,3	14	12	8	60
K0666.11650	-	M16	53,3	14	12	8	60

## Ball-end thrust screws without head

with flattened ball LONG-LOK secured



Form B  
with flattened ball

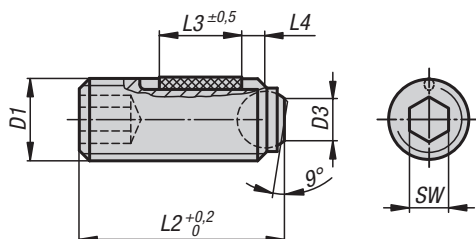

L4 = approx. two thread turns

**Material:**

Screw carbon steel, grade 10.9  
Ball, ball-bearing steel.  
LONG-LOK thread lock nylon.

**Version:**

Screw black.  
Ball hardened, bright.

**Sample order:**

K0666.20610

**Note:**

Surfaces which are not flat and parallel can be firmly clamped or supported with a flattened ball, the movable ball can adapt itself up to 9°.

### KIPP Ball-end thrust screws without head, with flattened ball, steel, LONG-LOK secured

Order No. Form B	D1	D3	L2	L3	Ball-Ø	SW	Load rating max. kN (static load only)
K0666.20610	M6	3	10,1	3,5	4	3	9
K0666.20616	M6	3	16,1	7	4	3	9
K0666.20620	M6	3	20,1	7	4	3	9
K0666.20625	M6	3	25,1	7	4	3	9
K0666.20650	M6	3	50,1	7	4	3	9
K0666.20660	M6	3	60,1	7	4	3	9
K0666.20810	M8	4,1	10,3	3,5	5,5	4	10
K0666.20812	M8	4,1	12,3	5	5,5	4	10
K0666.20820	M8	4,1	20,3	8	5,5	4	15
K0666.20825	M8	4,1	25,3	8	5,5	4	15
K0666.20830	M8	4,1	30,3	8	5,5	4	15
K0666.20850	M8	4,1	50,3	8	5,5	4	15
K0666.20860	M8	4,1	60,3	8	5,5	4	15
K0666.20880	M8	4,1	80,3	8	5,5	4	15
K0666.21012	M10	5,6	12,3	5	7	5	20
K0666.21016	M10	5,6	16,3	9	7	5	20
K0666.21020	M10	5,6	20,3	9	7	5	20
K0666.21025	M10	5,6	25,3	9	7	5	20
K0666.21035	M10	5,6	35,3	9	7	5	20
K0666.21216	M12	7	16,2	8	8,5	6	30
K0666.21220	M12	7	20,2	10	8,5	6	30
K0666.21230	M12	7	30,2	10	8,5	6	30
K0666.21240	M12	7	40,2	10	8,5	6	30
K0666.21620	M16	10,7	20	10	12	8	60
K0666.21625	M16	10,7	25	14	12	8	60
K0666.21635	M16	10,7	35	14	12	8	60
K0666.21650	M16	10,7	50	14	12	8	60



## Thrust screws with radiused half-dog point

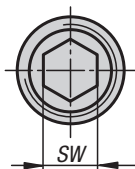
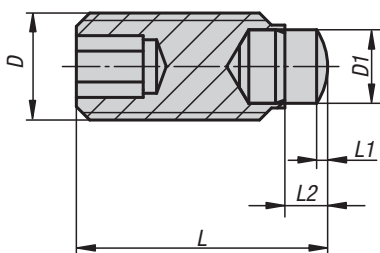

**Material:**

Screw steel grade 10.9.  
Pin tool steel.

**Version:**

Pin, hardened.  
Screw and pin black oxidised.

**Sample order:**

K0403.05X09

**Note:**

These radiused half-dog point thrust screws are used when a punctiform thrust or support point are required.

### KIPP Thrust screws with radiused half-dog point

Order No.	D	D1	L	L1	L2	SW	Load rating max. kN (static load only)
K0403.05X09	M 5	3	9	0,5	1,8	2,5	4,5
K0403.05X13	M 5	3	13	0,5	1,8	2,5	4,5
K0403.05X17	M 5	3	17	0,5	1,8	2,5	4,5
K0403.05X21	M 5	3	21	0,5	1,8	2,5	4,5
K0403.06X14	M 6	4	14,3	0,8	2,7	3	9
K0403.06X18	M 6	4	18,3	0,8	2,7	3	9
K0403.06X22	M 6	4	22,3	0,8	2,7	3	9
K0403.06X27	M 6	4	27,3	0,8	2,7	3	9
K0403.08X15	M 8	5,5	14,8	0,8	3,2	4	15
K0403.08X19	M 8	5,5	18,8	0,8	3,2	4	15
K0403.08X23	M 8	5,5	22,8	0,8	3,2	4	15
K0403.08X28	M 8	5,5	27,8	0,8	3,2	4	15
K0403.08X35	M 8	5,5	34,8	0,8	3,2	4	15
K0403.10X19	M10	7	18,9	1,1	3,5	5	20
K0403.10X23	M10	7	22,9	1,1	3,5	5	20
K0403.10X28	M10	7	27,9	1,1	3,5	5	20
K0403.10X35	M10	7	34,9	1,1	3,5	5	20
K0403.10X43	M10	7	42,9	1,1	3,5	5	20

## Thrust screws with point

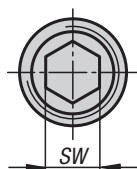
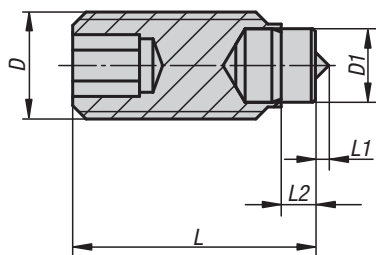
**Material:**

Screw steel grade 10.9.  
Pin tool steel.

**Version:**

Pin, hardened.  
Screw and pin black oxidised.

**Sample order:**

K0272.05X09

**Note:**

These thrust screws with point are used when additional positive fixation is required.

## KIPP Thrust screws with point

Order No.	D	D1	L	L1	L2	SW	Load rating max. kN (static load only)
K0272.05X09	M 5	3	8,5	0,5	1,3	2,5	4,5
K0272.05X13	M 5	3	12,5	0,5	1,3	2,5	4,5
K0272.05X17	M 5	3	16,5	0,5	1,3	2,5	4,5
K0272.05X21	M 5	3	20,5	0,5	1,3	2,5	4,5
K0272.06X14	M 6	4	13,5	0,8	1,9	3	9
K0272.06X18	M 6	4	17,5	0,8	1,9	3	9
K0272.06X22	M 6	4	21,5	0,8	1,9	3	9
K0272.06X27	M 6	4	26,5	0,8	1,9	3	9
K0272.08X14	M 8	5,5	14	1	2,4	4	15
K0272.08X18	M 8	5,5	18	1	2,4	4	15
K0272.08X22	M 8	5,5	22	1	2,4	4	15
K0272.08X27	M 8	5,5	27	1	2,4	4	15
K0272.08X34	M 8	5,5	34	1	2,4	4	15
K0272.10X18	M10	7	18	1,5	2,6	5	20
K0272.10X22	M10	7	22	1,5	2,6	5	20
K0272.10X27	M10	7	27	1,5	2,6	5	20
K0272.10X34	M10	7	34	1,5	2,6	5	20
K0272.10X42	M10	7	42	1,5	2,6	5	20

# Grippers and inserts

round

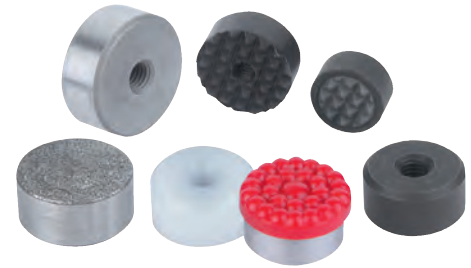

Form C, E, K

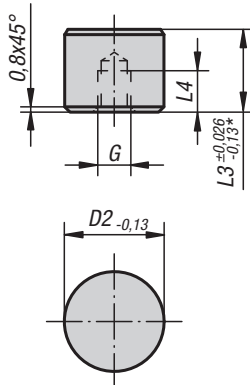

\* Applies to Form K

Form O  
stainless steel insert  
diamond impregnated

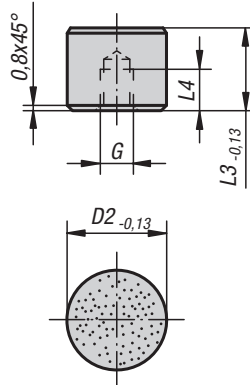

Form P  
stainless steel insert,  
PUR surface

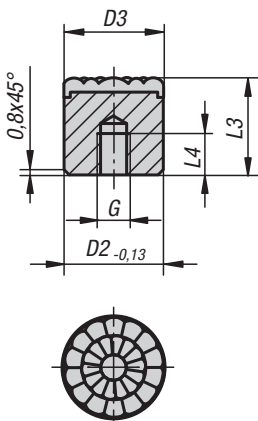

Form F  
diamond grip insert

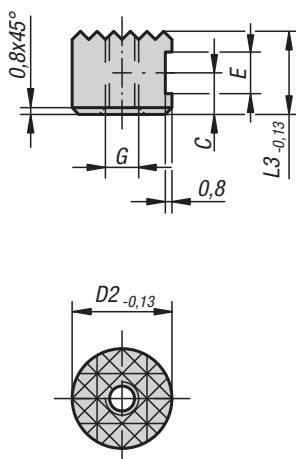

Form M  
carbide steel  
diamond grip

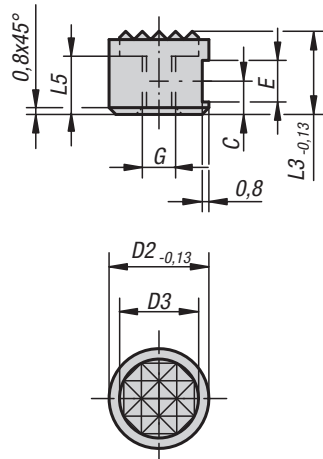

**Material:**

- Form C, F, M tool steel
- Form E, O, P stainless steel
- Form K POM

**Version:**

- Form C hardened and black oxidised.
- Form E hardened, bright.
- Form K white.
- Form O with diamond impregnated surface comparable to 100 grade abrasive grit.
- Form P with polyurethane surface, Shore hardness 60°.
- Form F, hardened and black oxidised.
- Form M with carbide serrations, black oxidised.

**Sample order:**

K0385.2510

**Note:**

Grippers and inserts are ideal for use in clamping arms, gripping systems, clamping fixtures, clamping jaws and self-aligning pads. The use of grippers allows the transfer of very high torque values and above average grip, even with hard materials and surface irregularities.

Form O: The abrasive diamond surface is bonded firmly to the base. It is ideally suited to supporting smooth or slippery applications with a minimum of clamping pressure. This allows the diamond particles to get a firm grip on a very small area with minimum damage to the surface. The diamond surface offers excellent wear resistance.

Form P: The polyurethane surface is vulcanised firmly to the ball. It is abrasion-resistant and does not discolour. It offers optimum protection against damage to delicate surfaces. The pearl-like surface gives a firm grip and allows air to escape so as to prevent any suction effect between the contact surface and the self-aligning pads.

Grippers and inserts can be fitted in the following self-aligning pads:

- Order No. K0285.117X022 up to K0285.936X036
- Order No. K0289.110X015 up to K0289.924X100
- Order No. K0291.120X030 up to K0291.924X080

## Grippers and inserts

round

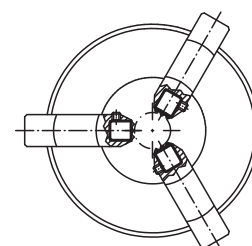

## KIPP Round inserts Form C, E, K, O

Order No. Form C	Order No. Form E	Order No. Form K	Order No. Form O	D2	L3	L4	G
K0385.10108	K0385.10102	K0385.10109	K0385.10105	10	10	5	M5
K0385.10128	K0385.10122	K0385.10129	K0385.10125	10	12	6,4	M5
K0385.12108	K0385.12102	K0385.12109	K0385.12105	12	10	5	M5
K0385.12128	K0385.12122	K0385.12129	K0385.12125	12	12	6,4	M5
K0385.16108	K0385.16102	K0385.16109	K0385.16105	16	10	5	M6
K0385.16128	K0385.16122	K0385.16129	K0385.16125	16	12	6,4	M6
K0385.20108	K0385.20102	K0385.20109	K0385.20105	20	10	5	M6
K0385.20128	K0385.20122	K0385.20129	K0385.20125	20	12	6,4	M6
K0385.25108	K0385.25102	K0385.25109	K0385.25105	25	10	5	M6
K0385.25128	K0385.25122	K0385.25129	K0385.25125	25	12	6,4	M6

## KIPP Round inserts Form P

Order No.	Form	D2	D3	L3	L4	G
K0385.08126	Form P	8	8	12	6	M4
K0385.10126	Form P	10	10	12	6	M5
K0385.12126	Form P	12	13	12	6	M5
K0385.16126	Form P	16	16	12	6	M6
K0385.20126	Form P	20	21	12	6	M6
K0385.25126	Form P	25	27	12	6	M6

## KIPP Grippers Form F, M

Order No. Form F	Order No. Form M	D2	D3	L3	L5	C	E	G
K0385.1010	K0385.10107	10	-7,9	10	-6	4,5	4,75	M5
K0385.1210	K0385.12107	12	-9,5	10	-6	4,5	4,75	M5
K0385.1212	K0385.12127	12	-9,5	12	-7	6	4,75	M5
K0385.1610	K0385.16107	16	-12,7	10	-6	4,5	4,75	M6
K0385.2010	K0385.20107	20	-15,9	10	-6	4,5	4,75	M6
K0385.2510	K0385.25107	25	-19	10	-6	4,5	4,75	M6

## Grippers and inserts

round, with counterbore

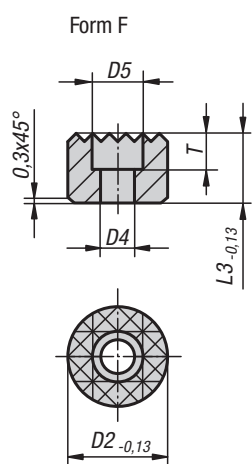
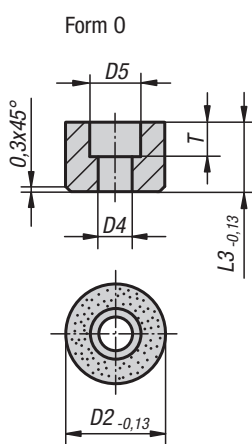
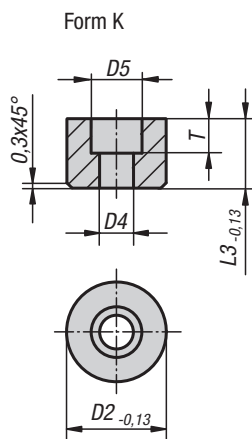
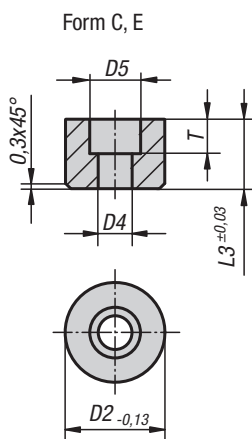
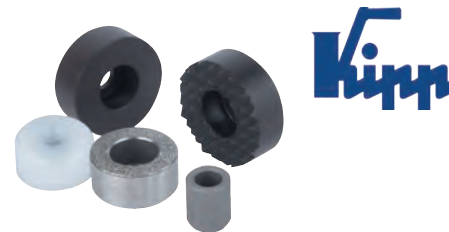

**Material:**

Form C, F tool steel  
 Form E, O stainless steel  
 Form K POM

**Version:**

Form C, F hardened and black oxidised.  
 Form E, hardened, bright.  
 Form K white.  
 Form O with diamond impregnated surface comparable to 100 grade abrasive grit.

**Sample order:**

K0385.110108

**Note:**

Grippers and inserts are ideal for use in clamping arms, gripping systems, clamping fixtures, clamping jaws and self-aligning pads. The use of grippers allows the transfer of very high torque values and above average grip, even with hard materials and surface irregularities.

Form O: The abrasive diamond surface is bonded firmly to the base. It is ideally suited to supporting smooth or slippery applications with a minimum of clamping pressure. This allows the diamond particles to get a firm grip on a very small area with minimum damage to the surface.

The diamond surface offers excellent wear resistance.

### KIPP Round inserts

Order No. Form C	Order No. Form E	Order No. Form K	Order No. Form O	D2	D4	D5	L3	T
K0385.110108	K0385.110102	K0385.110109	K0385.110105	10	3,4	6	10	5
K0385.110128	K0385.110122	K0385.110129	K0385.110125	10	3,4	6	12	5
K0385.112108	K0385.112102	K0385.112109	K0385.112105	12	4,5	9	10	5,6
K0385.112128	K0385.112122	K0385.112129	K0385.112125	12	4,5	9	12	5,6
K0385.116108	K0385.116102	K0385.116109	K0385.116105	16	5,5	11	10	6,6
K0385.116128	K0385.116122	K0385.116129	K0385.116125	16	5,5	11	12	6,6
K0385.120108	K0385.120102	K0385.120109	K0385.120105	20	6,6	11	10	7,6
K0385.120128	K0385.120122	K0385.120129	K0385.120125	20	6,6	11	12	7,6
K0385.125108	K0385.125102	K0385.125109	K0385.125105	25	6,6	11	10	7,6
K0385.125128	K0385.125122	K0385.125129	K0385.125125	25	6,6	11	12	7,6

### KIPP Round grippers

Order No. Form F	D2	D4	D5	L3	T
K0385.11210	12	4,5	8	10	5,6
K0385.11212	12	4,5	8	12	5,6
K0385.11610	16	4,5	8	10	5,6
K0385.11612	16	4,5	8	12	5,6
K0385.12010	20	5,5	10	10	6,6
K0385.12012	20	5,5	10	12	6,6
K0385.12510	25	6,6	11	10	7,6
K0385.12512	25	6,6	11	12	7,6



## Gripper screws

hexagonal

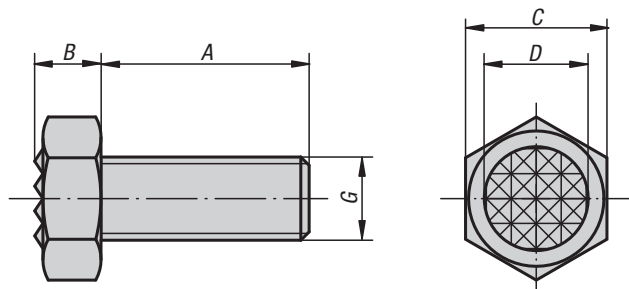

**Material:**  
Hex head screw, grade 10.9.  
Serrations carbide, hardness 72-74 HRC.

**Version:**  
Black oxidised.

**Sample order:**  
K0386.1710

**Note:**  
The serrated carbide tips are soldered in.



### KIPP Gripper screws hex head

Order No.	A	B	C	D	G	Serration
K0386.1006	25	5	10	7,9	M6	superfine
K0386.1308	25	6,4	13	9,5	M8	fine
K0386.1710	25	8,3	17	12,7	M10	fine
K0386.17102	40	8,3	17	12,7	M10	fine
K0386.1912	25	8,7	19	15,9	M12	fine
K0386.19122	40	8,7	19	15,9	M12	fine
K0386.2416	35	11	24	19	M16	fine
K0386.24162	50	11	24	19	M16	fine
K0386.3020	40	13,7	30	25,4	M20	superfine
K0386.30202	60	13,7	30	25,4	M20	superfine

## Gripper pads

square

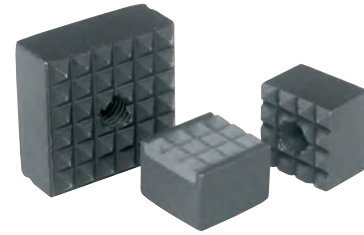

Form A  
tool steel

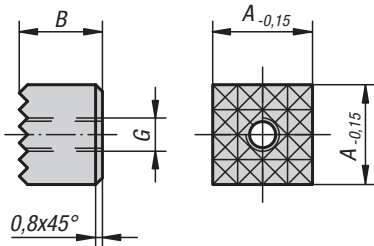

Form B  
tool steel  
carbide diamond grip

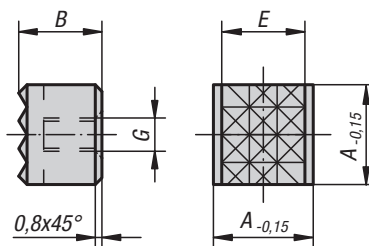

Form C  
tool steel

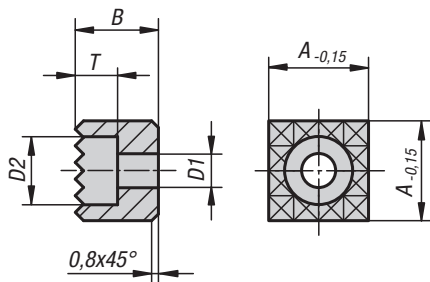

**Material:**

Hardened tool steel or carbide.

**Version:**

Black oxidised.

**Sample order:**

K0387.2506

**Note:**

Grippers and inserts are ideal for use in clamping arms, gripping systems, clamping fixtures, clamping jaws and self-aligning pads.

Grippers transfer very high torque values, even with hard materials and surface irregularities. Grippers guarantee above average holding forces at high cutting forces.

The serrated carbide tips are soldered in.

### KIPP Grippers square

Order No.	Form	A	B	D1	D2	E	G	T	Serration
K0387.1005	A	10	10	-	-	-	M5	-	superfine
K0387.101205	A	10	12	-	-	-	M5	-	superfine
K0387.1205	A	12	10	-	-	-	M5	-	fine
K0387.121205	A	12	12	-	-	-	M5	-	fine
K0387.1606	A	16	10	-	-	-	M6	-	fine
K0387.161206	A	16	12	-	-	-	M6	-	fine
K0387.2005	A	20	10	-	-	-	M5	-	fine
K0387.201205	A	20	12	-	-	-	M5	-	fine
K0387.2506	A	25	10	-	-	-	M6	-	fine
K0387.251206	A	25	12	-	-	-	M6	-	fine
K0387.12057	B	12	10	-	-	10,3	M5	-	fine
K0387.1210048	C	12	10	4,5	8	-	-	5,6	fine
K0387.1212048	C	12	12	4,5	8	-	-	5,6	fine
K0387.1610048	C	16	10	4,5	8	-	-	5,6	fine
K0387.1612048	C	16	12	4,5	8	-	-	5,6	fine
K0387.2010058	C	20	10	5,5	10	-	-	6,6	fine
K0387.2012058	C	20	12	5,5	10	-	-	6,6	fine
K0387.2510068	C	25	10	6,6	11	-	-	7,6	fine
K0387.2512068	C	25	12	6,6	11	-	-	7,6	fine

## Gripper studs



Form A  
tool steel

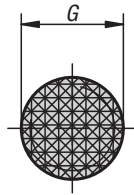
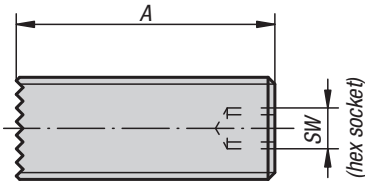

**Material:**  
Hardened tool steel or carbide.

**Version:**  
Black oxidised.

**Sample order:**  
K0388.5012

**Note:**  
The full thread on the grippers allows exact adjustment to the clamping application. The carbide tips are soldered in.

Form B  
carbide diamond grip

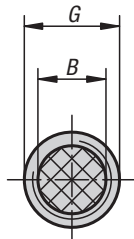
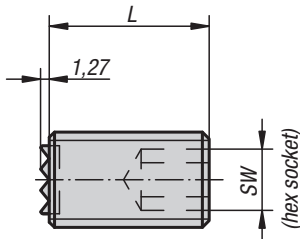

Form C  
4-point carbide insert

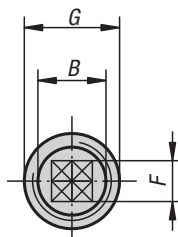
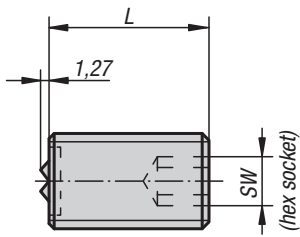

### KIPP Gripper studs

Order No.	Form	A	L	B	G	F	SW
K0388.4010	A	40	-	-	M10	-	3
K0388.4012	A	40	-	-	M12	-	5
K0388.4016	A	40	-	-	M16	-	6
K0388.4020	A	40	-	-	M20	-	8
K0388.2510	B	-	25	6,4	M10	-	5
K0388.5010	B	-	50	6,4	M10	-	5
K0388.2512	B	-	25	7,9	M12	-	6
K0388.5012	B	-	50	7,9	M12	-	6
K0388.2516	B	-	25	11,2	M16	-	8
K0388.5016	B	-	50	11,2	M16	-	8
K0388.2520	B	-	25	12,7	M20	-	10
K0388.5020	B	-	50	12,7	M20	-	10
K0388.25124	C	-	25	7,9	M12	6,5	6
K0388.50124	C	-	50	7,9	M12	6,5	6
K0388.25164	C	-	25	11,2	M16	8	8
K0388.50164	C	-	50	11,2	M16	8	8
K0388.25204	C	-	25	12,7	M20	8	10
K0388.50204	C	-	50	12,7	M20	8	10

## Thrust screws

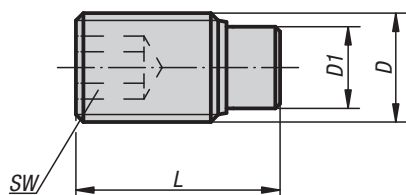
**Material:**

Screw grade 10.9.  
Pin brass or POM.

**Version:**

Screw black oxidised.

**Sample order:**

K0389.04X105 (include length L.)

**Note:**

Thrust screws are ideal for clamping or exerting pressure on threaded spindles, axles, shafts and treated surfaces without marring. Longer versions are specially designed to be glued in, allowing small to medium series of mechanical external thread fastening elements to be made cost-effectively.

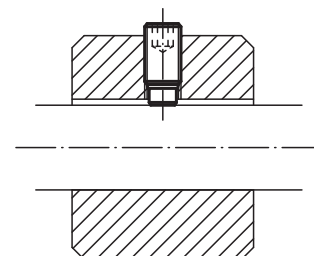

## KIPP Thrust screws

Order No.	Version	D	D1	L	SW
K0389.04X	pin brass	M4	2,5	6,5/10,5/16,5/30,5/40,5	2
K0389.05X	pin brass	M5	3	8,5/12,5/20,5/30,5/40,5	2,5
K0389.06X	pin brass	M6	4	11,5/17,5/26,5/41,5/51,5/61,5	3
K0389.08X	pin brass	M8	5,5	12/22/32/52/62/82	4
K0389.10X	pin brass	M10	7	14/18/27/37/52/62/82	5
K0389.12X	pin brass	M12	8,5	18,5/22,5/32,5/42,5/52,5/62,5/82,5	6

Order No.	Version	D	D1	L	SW
K0389.104X	pin POM	M4	2	7/9/11/13/17/31/41	2
K0389.105X	pin POM	M5	3	9/11/13/17/21/31/41	2,5
K0389.106X	pin POM	M6	3,5	11,3/13,3/17,3/21,3/26,3/41,3/51,3/61,3	3
K0389.108X	pin POM	M8	5	13,6/17,6/21,6/26,6/33,6/51,6/61,6/81,6	4
K0389.110X	pin POM	M10	6,5	17,9/21,9/26,9/33,9/41,9/51,9/61,9/81,9	5
K0389.112X	pin POM	M12	8	22,1/27,1/34,1/42,1/52,1/62,1/82,1	6

# Thrust screws

stainless steel



**Material:**

Screw stainless steel.  
Pin brass or POM.

**Version:**

Screw bright.

**Sample order:**

K0667.041X105 (include length L.)

**Note:**

Thrust screws are ideal for clamping or exerting pressure on threaded spindles, axles, shafts and treated surfaces without marring. Longer versions are specially designed to be glued in, allowing small to medium series of mechanical external thread fastening elements to be made cost-effectively.

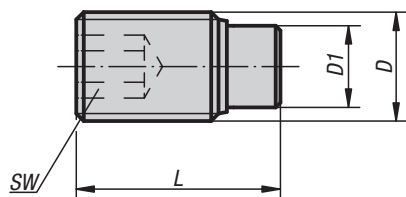

## KIPP Thrust screws, stainless steel

Order No.	Version	D	D1	L	SW
K0667.041X	pin brass	M4	2,5	6,5/10,5/16,5/30,5/40,5	2
K0667.051X	pin brass	M5	3	8,5/12,5/20,5/30,5/40,5	2,5
K0667.061X	pin brass	M6	4	11,5/13,5/17,5/21,5/26,5/41,5/51,5/61,5	3
K0667.081X	pin brass	M8	5,5	12/22/32/52/62/82	4
K0667.101X	pin brass	M10	7	14/18/27/37	5
K0667.121X	pin brass	M12	8,5	22,5/32,5/42,5	6

Order No.	Version	D	D1	L	SW
K0667.1041X	pin POM	M4	2	7/9/11/13/17/31/41	2
K0667.1051X	pin POM	M5	3	9/11/13/17/21/31/41	2,5
K0667.1061X	pin POM	M6	3,5	11,3/13,3/17,3/21,3/26,3/41,3/51,3/61,3	3
K0667.1081X	pin POM	M8	5	13,6/17,6/21,6/26,6/33,6/51,6/61,6/81,6	4
K0667.1101X	pin POM	M10	6,5	17,9/21,9/26,9/36,9	5
K0667.1121X	pin POM	M12	8	22,1/32,1/42,1	6

## Thrust screws

LONG-LOK secured

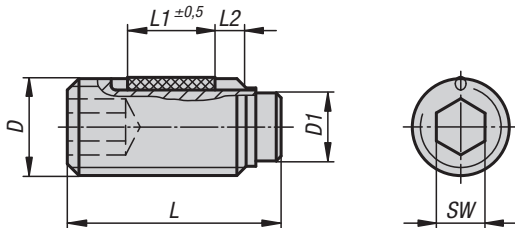

L2 = approx. two thread turns

**Material:**

Screw grade 10.9.  
Pin brass or POM.  
LONG-LOK thread lock nylon.

**Version:**

Screw black oxidised.

**Sample order:**

K0668.204X65 (include length L)

**Note:**

Thrust screws are ideal for clamping or exerting pressure on threaded spindles, axles, shafts and treated surfaces without marring. Longer versions are specially designed to be glued in, allowing small to medium series of mechanical external thread fastening elements to be made cost-effectively.

### KIPP Thrust screws, LONG-LOK secured

Order No.	Version	D	D1	L (L1)	SW
K0668.204X	pin brass	M4	2,5	6,5 (2,5)/10,5 (3,5)/16,5 (5)/30,5 (5)/40,5 (5)	2
K0668.205X	pin brass	M5	3	8,5 (3,5)/12,5 (5)/20,5 (6)/30,5 (6)/40,5 (6)	2,5
K0668.206X	pin brass	M6	4	11,5 (3,5)/17,5 (7)/26,5 (7)/41,5 (7)/51,5 (7)/61,5 (7)	3
K0668.208X	pin brass	M8	5,5	12 (3,5)/22 (8)/32 (8)/52 (8)/62 (8)/82 (8)	4
K0668.210X	pin brass	M10	7	14 (5)/18 (9)/27 (9)/37 (9)/52 (9)/62 (9)/82 (9)	5
K0668.212X	pin brass	M12	8,5	18,5 (8)/22,5 (10)/32,5 (10)/42,5 (10)/52,5 (10)/62,5 (10)/82,5 (10)	6

Order No.	Version	D	D1	L (L1)	SW
K0668.304X	pin POM	M4	2	7 (2,5)/9 (3,5)/11 (3,5)/13 (5)/17 (5)/31 (5)/41 (5)	2
K0668.305X	pin POM	M5	3	9 (3,5)/11 (3,5)/13 (5)/17 (6)/21 (6)/31 (6)/41 (6)	2,5
K0668.306X	pin POM	M6	3,5	11,3 (3,5)/13,3 (5)/17,3 (7)/21,3 (7)/26,3 (7)/41,3 (7)/51,3 (7)/61,3 (7)	3
K0668.308X	pin POM	M8	5	13,6 (5)/17,6 (8)/21,6 (8)/26,6 (8)/33,6 (8)/51,6 (8)/61,6 (8)/81,6 (8)	4
K0668.310X	pin POM	M10	6,5	17,9 (9)/21,9 (9)/26,9 (9)/33,9 (9)/41,9 (9)/51,9 (9)/61,9 (9)/81,9 (9)	5
K0668.312X	pin POM	M12	8	22,1 (10)/27,1 (10)/34,1 (10)/42,1 (10)/52,1 (10)/62,1 (10)/82,1 (10)	6

## Locating pins

with ball-end Form A

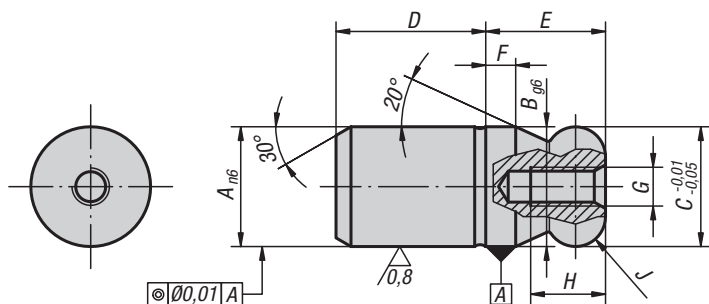

**Material:**  
Tool steel or stainless steel 1.4305.

**Version:**  
Steel hardened and ground.  
Stainless steel ground and kolsterised.

**Sample order:**  
K0350.12

**Note:**  
Ball end locating pins are specially designed to ease the locating process. The tendency to jam, caused by the locating hole not being at right angles to the pin or by the pushing force not being parallel to the pin axis, is minimized by the ball-end form. (See the illustration for K0351 Form B)

### KIPP Locating pins with ball-end Form A

Order No. steel	Order No. stainless steel	A	B	C	D	E	F	G	H	J
K0350.08	K0350.508	8	8	8	10	8	2	M3	6	R 2
K0350.10	K0350.510	10	10	10	13	10	2,5	M3	6	R 2,5
K0350.12	K0350.512	12	12	12	15	12	3	M4	8	R 3
K0350.16	K0350.516	16	16	16	20	16	4	M5	10	R 4
K0350.20	K0350.520	20	20	20	25	20	5	M5	10	R 5
K0350.25	-	25	25	25	25	25	6	M5	10	R 6
K0350.30	-	30	30	30	30	30	8	M6	12	R 8
K0350.40	-	40	40	40	40	40	10	M6	12	R 10
K0350.50	-	50	50	50	50	50	12	M6	12	R 12

## Locating pins

with flattened ball end Form C

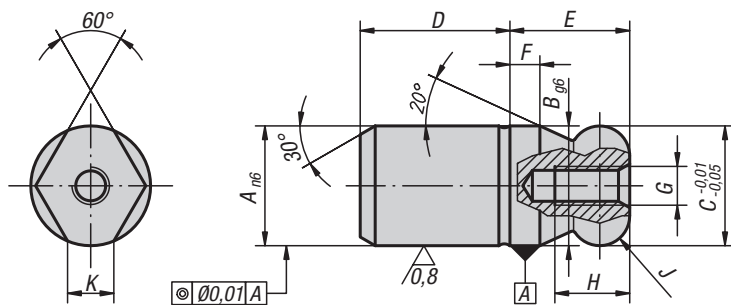

**Material:**  
Tool steel or stainless steel 1.4305.

**Version:**  
Steel hardened and ground.  
Stainless steel ground and kolsterised.

**Sample order:**  
K0350.162

**Note:**  
Ball end locating pins are specially designed to ease the locating process. The tendency to jam, caused by the locating hole not being at right angles to the pin or by the pushing force not being parallel to the pin axis, is minimized by the ball-end form (see illustration for K0351 Form B)

### KIPP Locating pins with flattened ball-end Form C

Order No. steel	Order No. stainless steel	A	B	C	D	E	F	G	H	J	K
K0350.082	K0350.5082	8	8	8	10	8	2	M3	6	R 2	1,9
K0350.102	K0350.5102	10	10	10	13	10	2,5	M3	6	R 2,5	2,5
K0350.122	K0350.5122	12	12	12	15	12	3	M4	8	R 3	2,5
K0350.162	K0350.5162	16	16	16	20	16	4	M5	10	R 4	4,3
K0350.202	K0350.5202	20	20	20	25	20	5	M5	10	R 5	5
K0350.252	-	25	25	25	25	25	6	M5	10	R 6	5,6
K0350.302	-	30	30	30	30	30	8	M6	12	R 8	8,8
K0350.402	-	40	40	40	40	40	10	M6	12	R 10	12,8
K0350.502	-	50	50	50	50	50	12	M6	12	R 12	16,7

## Locating pins

with ball-end Form B

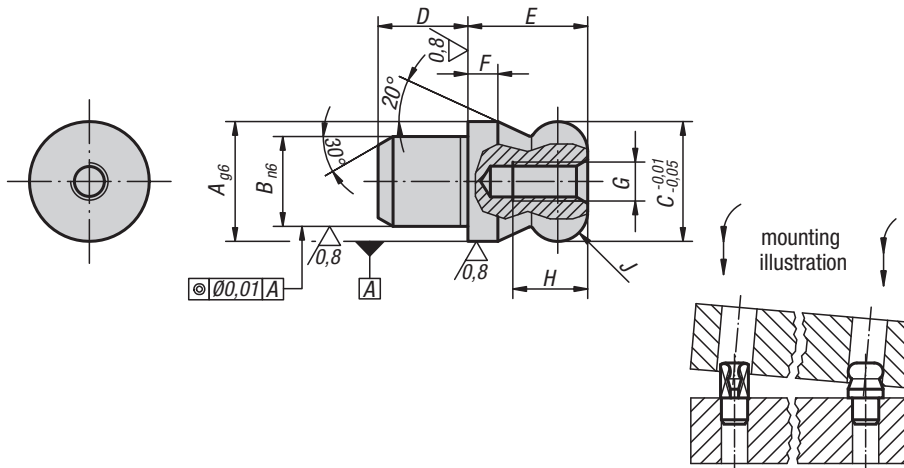

**Material:**  
Tool steel or stainless steel 1.4305.

**Version:**  
Steel hardened and ground.  
Stainless steel ground and kolsterised.

**Sample order:**  
K0351.20

**Note:**  
Ball end locating pins are specially designed to ease the locating process. The tendency to jam, caused by the locating hole not being at right angles to the pin or by the pushing force not being parallel to the pin axis, is minimized by the ball-end form (see illustration).

### KIPP Locating pins with ball-end Form B

Order No. steel	Order No. stainless steel	A	B	C	D	E	F	G	H	J
K0351.10	K0351.510	10	7	10	7	10	2,5	M3	6	R 2,5
K0351.12	K0351.512	12	8	12	8	12	3	M4	8	R 3
K0351.16	K0351.516	16	12	16	12	16	4	M5	10	R 4
K0351.20	K0351.520	20	14	20	14	20	5	M5	10	R 5
K0351.22	-	22	16	22	16	22	5,5	M5	10	R 5,5
K0351.25	-	25	18	25	18	25	6	M5	10	R 6

## Locating pins

with flattened ball-end Form D

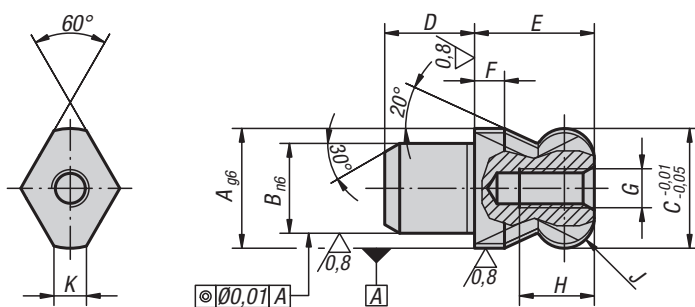

**Material:**  
Tool steel or stainless steel 1.4305.

**Version:**  
Steel hardened and ground.  
Stainless steel ground and kolsterised.

**Sample order:**  
K0351.162

**Note:**  
Ball end locating pins are specially designed to ease the locating process. The tendency to jam, caused by the locating hole not being at right angles to the pin or by the pushing force not being parallel to the pin axis, is minimized by the ball-end form (see illustration for K0351 Form B)

### KIPP Locating pins with flattened ball-end Form D

Order No. steel	Order No. stainless steel	A	B	C	D	E	F	G	H	J	K
K0351.102	K0351.5102	10	7	10	7	10	2,5	M3	6	R 2,5	2,5
K0351.122	K0351.5122	12	8	12	8	12	3	M4	8	R 3	2,5
K0351.162	K0351.5162	16	12	16	12	16	4	M5	10	R 4	4,3
K0351.202	K0351.5202	20	14	20	14	20	5	M5	10	R 5	5
K0351.222	-	22	16	22	16	22	5,5	M5	10	R 5,5	5
K0351.252	-	25	18	25	18	25	6	M5	10	R 6	5,6



## Positioning pins cylindrical

ground

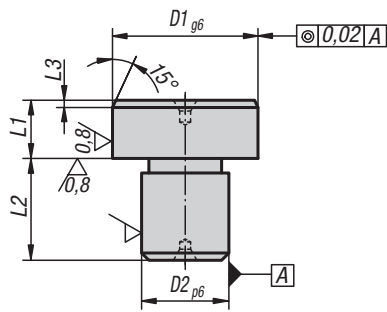

**Material:**  
Tool steel.

**Version:**  
Hardened and ground.

**Sample order:**  
K0352.08

**Note:**  
Top face with centre hole.

### KIPP Cylindrical positioning pins, ground

Order No.	Version	D1	D2	L1	L2	L3
K0352.05	D1 ground	8	5	8	8	2
K0352.07	D1 ground	10	7	8	8	2
K0352.08	D1 ground	12	8	8	10	2
K0352.081	D1 ground	14	8	8	10	3
K0352.09	D1 ground	16	9	8	12	3
K0352.12	D1 ground	18	12	8	12	3
K0352.121	D1 ground	20	12	8	14	3
K0352.14	D1 ground	22	14	8	14	3
K0352.16	D1 ground	25	16	8	16	3

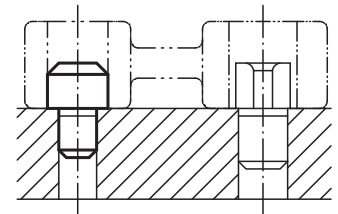

# K0353

## Positioning pins cylindrical

not ground

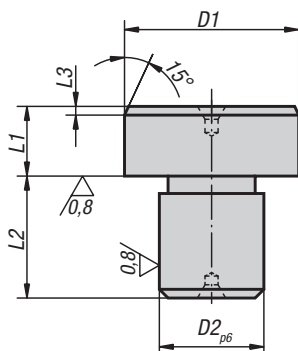

**Material:**  
Tool steel.

**Version:**  
Hardened.

**Sample order:**  
K0353.05

**Note:**  
Top face with centre hole.

### KIPP Cylindrical positioning pins, not ground

Order No.	Version	D1	D2	L1	L2	L3
K0353.05	D1 not ground	8,5	5	8	8	2
K0353.07	D1 not ground	10,5	7	8	8	2
K0353.08	D1 not ground	12,5	8	8	10	2
K0353.081	D1 not ground	14,5	8	8	10	3
K0353.09	D1 not ground	16,5	9	8	12	3
K0353.12	D1 not ground	18,5	12	8	12	3
K0353.121	D1 not ground	20,5	12	8	14	3
K0353.14	D1 not ground	22,5	14	8	14	3
K0353.16	D1 not ground	25,5	16	8	16	3

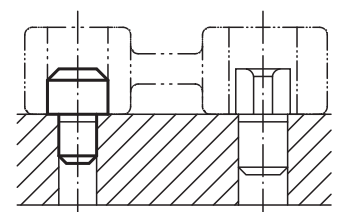

## Positioning pins free-milled

ground



**Material:**  
Tool steel.

**Version:**  
Hardened and ground.

**Sample order:**  
K0354.08

**Note:**  
Top face with centre hole.

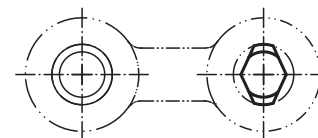
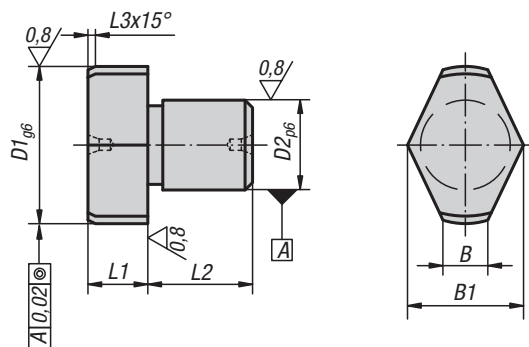

### KIPP Free-milled positioning pins ground

Order No.	Version	D1	D2	L1	L2	L3	B	B1
K0354.05	D1 ground	8	5	8	8	2	2	6,6
K0354.07	D1 ground	10	7	8	8	2	3	8,6
K0354.08	D1 ground	12	8	8	10	2	3	9,8
K0354.081	D1 ground	14	8	8	10	3	3,5	11,2
K0354.09	D1 ground	16	9	8	12	3	4	13,2
K0354.12	D1 ground	18	12	8	12	3	4,5	14,7
K0354.121	D1 ground	20	12	8	14	3	5	16,6
K0354.14	D1 ground	22	14	8	14	3	5,6	18
K0354.16	D1 ground	25	16	8	16	3	6	19,8

## Positioning pins free-milled

not ground



**Material:**  
Tool steel.

**Version:**  
Hardened.

**Sample order:**  
K0355.05

**Note:**  
Top face with centre hole.

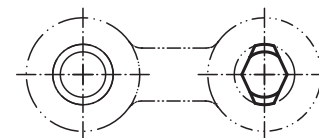
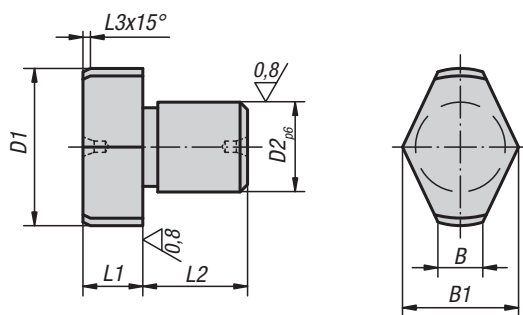

### KIPP Free-milled positioning pins, not ground

Order No.	Version	D1	D2	L1	L2	L3	B	B1
K0355.05	D1 not ground	8,5	5	8	8	2	2	6,6
K0355.07	D1 not ground	10,5	7	8	8	2	3	8,6
K0355.08	D1 not ground	12,5	8	8	10	2	3	9,8
K0355.081	D1 not ground	14,5	8	8	10	3	3,5	11,2
K0355.09	D1 not ground	16,5	9	8	12	3	4	13,2
K0355.12	D1 not ground	18,5	12	8	12	3	4,5	14,7
K0355.121	D1 not ground	20,5	12	8	14	3	5	16,6
K0355.14	D1 not ground	22,5	14	8	14	3	5,6	18
K0355.16	D1 not ground	25,5	16	8	16	3	6	19,8

## Locating pins expanding



**Material:**

Carbon steel.

**Version:**

Tempered and black oxidised.  
Locating diameter and guide faces ground.

**Sample order:**

K0356.1610

**Note:**

These expanding locating pins allow grid plates, for example, to be positioned on the T-slots of machine tables (see illustration).

The plates to be positioned must have two holes matching the expanding pin.

The expansion screw has a through broached hexagon socket allowing the pin to be tightened or loosened from two sides.

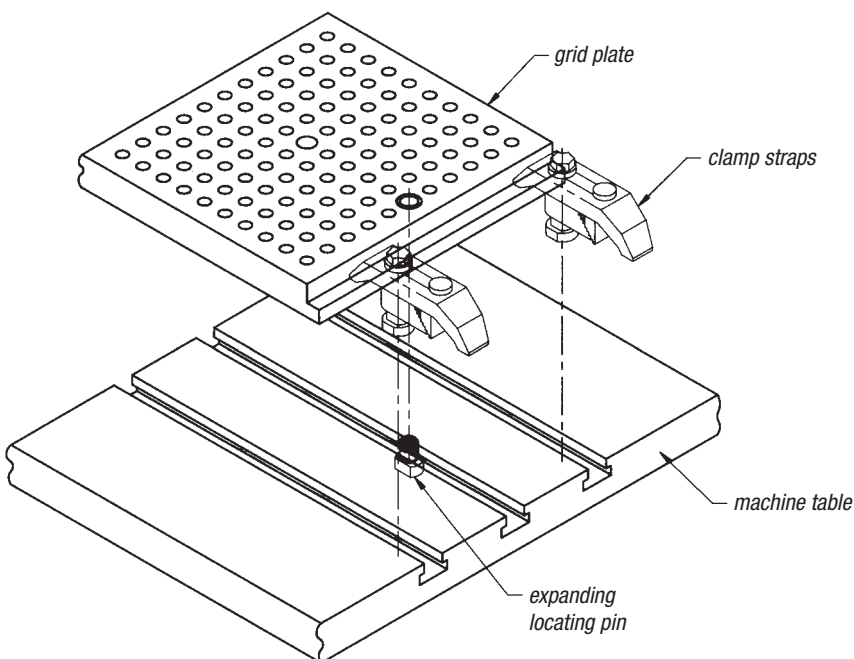
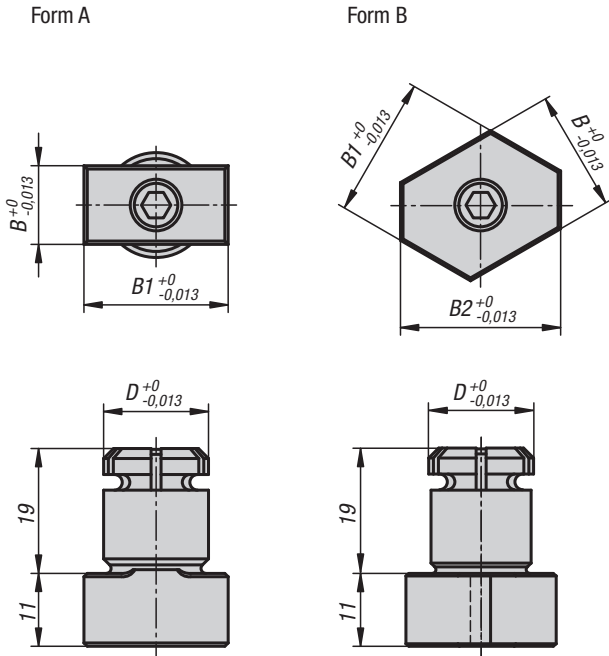

### KIPP Locating pins, expanding

Order No.	Form	D	B	B1	B2	Recommended Ø
K0356.1610	A	16	10	20	-	16,01 ±0,01
K0356.1612	A	16	12	22	-	16,01 ±0,01
K0356.1614	B	16	14	16	18	16,01 ±0,01
K0356.2024	B	20	24	28	32	20,01 ±0,01

## Rest pads



**Material:**  
Tool steel.

**Version:**  
Hardened and ground.  
No centre bore on top face.

**Sample order:**  
K0292.041

**Note:**  
If more than one rest pad is used, the support height can be reground. Rest pads can also be used as feet for jigs and fixtures.

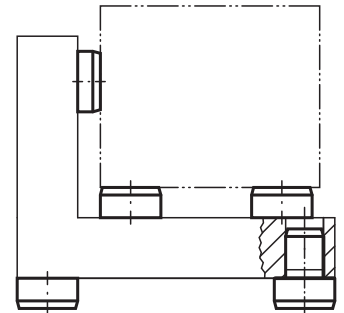
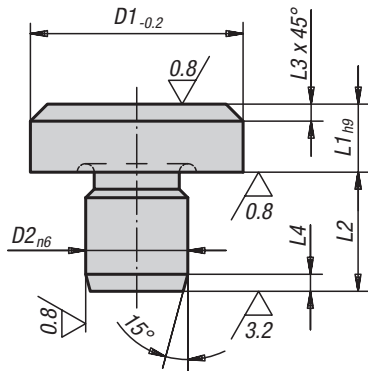

### KIPP Rest pads

Order No.	D1	L1	D2	L2	L3	L4
K0292.041	6	2,5	4	6,5	0,7	1,2
K0292.042	6	4,5	4	8,5	0,7	1,2
K0292.04	6	5	4	6	0,7	1,2
K0292.061	10	4,5	6	8,5	0,9	1,5
K0292.06	10	8	6	8,5	0,9	1,5
K0292.08	16	5	8	10	2	2
K0292.081	16	13	8	10	2	2
K0292.10	20	6	10	12	2	2
K0292.101	20	12	10	12	2	2
K0292.12	25	8	12	14	2	2
K0292.122	25	20	12	14	2	2
K0292.123	25	30	12	14	2	2
K0292.16	30	25	16	20	2,5	2,5
K0292.164	30	40	16	20	2,5	2,5
K0292.165	30	50	16	20	2,5	2,5
K0292.166	30	65	16	20	2,5	2,5
K0292.20	30	80	20	20	2,5	2,5
K0292.201	30	100	20	20	2,5	2,5
K0292.202	40	13	20	20	3,2	3,2
K0292.203	40	32	20	20	3,2	3,2



## Locating pins and rest pads

DIN 6321 (Issue 1973)



**Material:**  
Tool steel.

**Version:**  
Hardened and ground.

**Sample order:**  
K0293.212

**Note:**  
Rest pads Form A are supports for workpieces and fixtures.  
Locating pins Form B are for positioning workpieces and fixture components in reamed holes.  
The flattened Form C can be used to bridge tolerances in hole spacing or to secure the part to be positioned in one direction only.  
Form A and B can also be used as hardened stops and as fixture feet.  
For similar pins see K0352, K0353, K0354 and K0355.

Form A  
rest pad

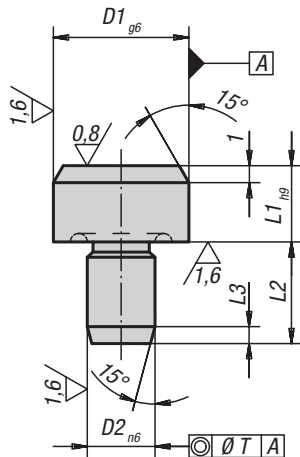

Form B  
cylindrical  
locating pin

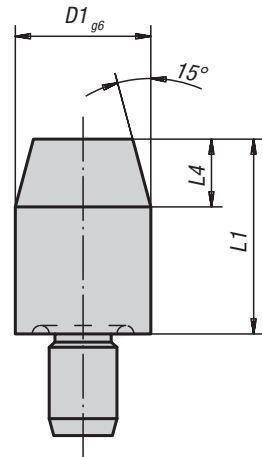

other dimensions and data same as Form A

Form C  
flattened  
locating pin

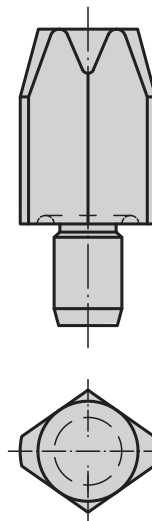

### KIPP Locating pins and rest pads

Order No.	Form	Version	D1	L1	D2	L2	L3	T
K0293.106	A	without centrebore	6	5	4	6	1,2	0,02
K0293.110	A	without centrebore	10	6	6	9	1,6	0,02
K0293.116	A	without centrebore	16	8	8	12	2	0,04
K0293.125	A	without centrebore	25	10	12	18	2,5	0,04

### KIPP Locating pins, short

Order No. Form B	Order No. Form C	D1	L1	D2	L2	L3	L4	B	T
K0293.206	K0293.406	6	7	4	6	1,2	4	-1	0,02
K0293.208	K0293.408	8	10	6	9	1,6	6	-1,6	0,02
K0293.210	K0293.410	10	10	6	9	1,6	6	-2,5	0,02
K0293.212	K0293.412	12	10	6	9	1,6	6	-2,5	0,02
K0293.216	K0293.416	16	13	8	12	2	8	-3,5	0,04
K0293.220	K0293.420	20	15	12	18	2,5	9	-5	0,04
K0293.225	K0293.425	25	15	12	18	2,5	9	-5	0,04

### KIPP Locating pins, long

Order No. Form B	Order No. Form C	D1	L1	D2	L2	L3	L4	B	T
K0293.306	K0293.506	6	12	4	6	1,2	4	-1	0,02
K0293.308	K0293.508	8	16	6	9	1,6	6	-1,6	0,02
K0293.310	K0293.510	10	18	6	9	1,6	6	-2,5	0,02
K0293.312	K0293.512	12	18	6	9	1,6	6	-2,5	0,02
K0293.316	K0293.516	16	22	8	12	2	8	-3,5	0,04
K0293.320	K0293.520	20	25	12	18	2,5	9	-5	0,04
K0293.325	K0293.525	25	25	12	18	2,5	9	-5	0,04

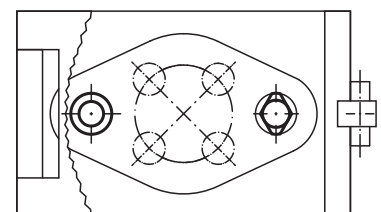
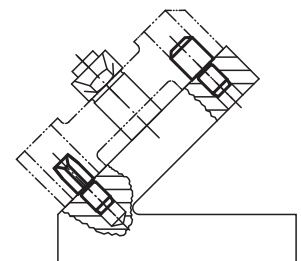

## Positioning feet



Form A  
with external thread  
and smooth face

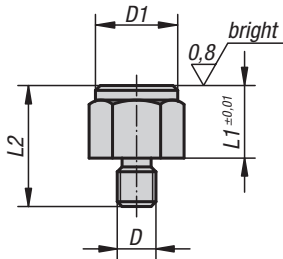

Form B  
with external thread  
and spherical surface

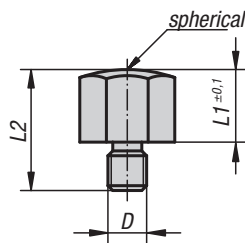

Form C  
with external thread  
and serrated surface

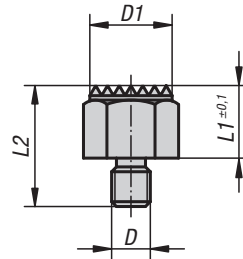

Form D  
with internal thread  
and smooth face

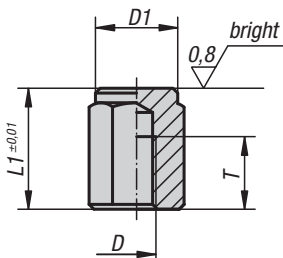

Form E  
with internal thread  
and spherical surface

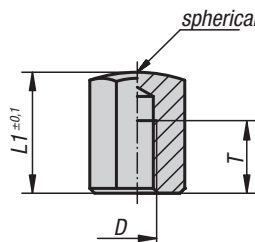

Form F  
with internal thread  
and serrated surface

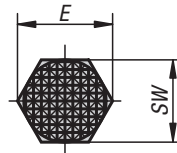
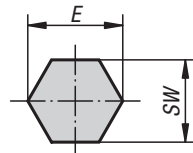
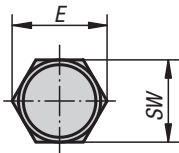
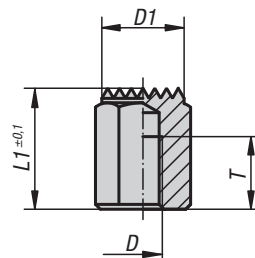

**Material:**  
Steel.

**Version:**  
Case-hardened and black oxidised.

**Sample order:**  
K0298.215

**Note:**  
Positioning feet are used as supports, stops and thrust pads for fixtures and general machine and appliance construction.

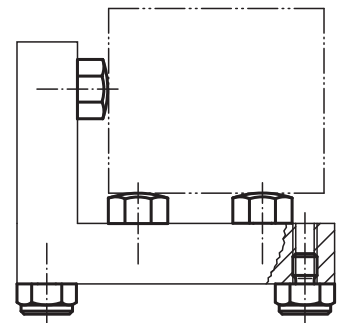

### KIPP Positioning feet with external thread

Order No. Form A	Order No. Form B	Order No. Form C	D	L1	D1	L2	E	SW	Tightening torque max. Nm
K0298.1101	K0298.2101	K0298.3101	M8	10	17/-/17	20	19,4	17	18
K0298.110	K0298.210	K0298.310	M12	10	22/-/22	24	25,2	22	60
K0298.115	K0298.215	K0298.315	M12	15	22/-/22	29	25,2	22	60
K0298.1151	K0298.2151	K0298.3151	M16	15	30/-/30	34	33	30	140
K0298.1201	K0298.2201	K0298.3201	M16	20	30/-/30	39	33	30	140

### KIPP Positioning feet with internal thread

Order No. Form D	Order No. Form E	Order No. Form F	D	L1	D1	T	E	SW
K0298.415	K0298.515	K0298.615	M8	15	17/-/17	6	19,4	17
K0298.4251	K0298.5251	K0298.6251	M8	25	17/-/17	16	19,4	17
K0298.420	K0298.520	K0298.620	M12	20	22/-/22	10	25,2	22
K0298.425	K0298.525	K0298.625	M12	25	22/-/22	15	25,2	22
K0298.430	K0298.530	K0298.630	M12	30	22/-/22	20	25,2	22
K0298.440	K0298.540	K0298.640	M12	40	22/-/22	25	25,2	22
K0298.450	K0298.550	K0298.650	M12	50	22/-/22	25	25,2	22
K0298.4301	K0298.5301	K0298.6301	M16	30	30/-/30	20	33	30
K0298.4501	K0298.5501	K0298.6501	M16	50	30/-/30	25	33	30

## Positioning feet



Form A  
hardened smooth face

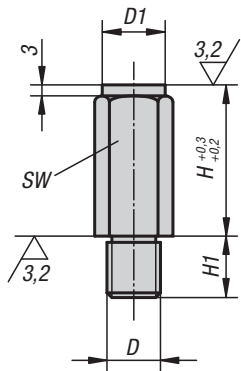

Form B  
smooth face hardened  
and ground

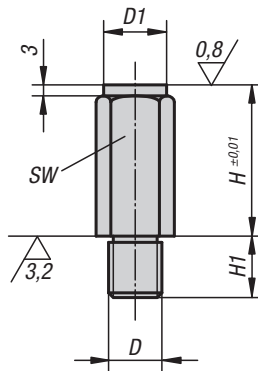

Form C  
hardened spherical surface

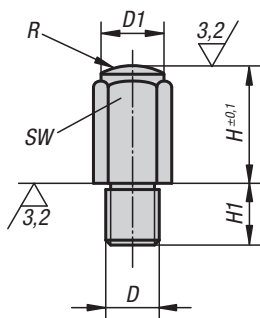

Form D  
tempered serrated surface

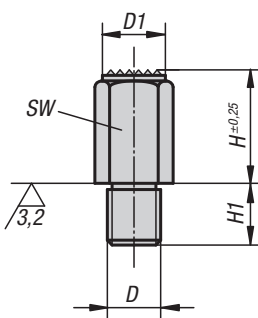

**Material:**  
Body carbon steel.

**Version:**  
Body tempered and black oxidised.  
Contact faces case-hardened.

**Sample order:**  
K0299.106010

**Note:**  
The positioning feet act as supports for rough and machined parts. They can also be used as stops and thrust pads in fixtures and toolmaking.

### KIPP Positioning feet

Order No. Form A	Order No. Form B	Order No. Form C	Order No. Form D	D	D1	H	H1	R	SW
K0299.106010	K0299.206010	K0299.306010	K0299.406010	M6	10	10	11	-/-/15/-	10
K0299.106020	K0299.206020	K0299.306020	K0299.406020	M6	10	20	11	-/-/15/-	10
K0299.108010	K0299.208010	K0299.308010	-	M8	13	10	13	-/-/20	13
K0299.108015	K0299.208015	K0299.308015	K0299.408015	M8	13	15	13	-/-/20/-	13
K0299.108030	K0299.208030	K0299.308030	K0299.408030	M8	13	30	13	-/-/20/-	13
K0299.110010	K0299.210010	K0299.310010	-	M10	17	10	16	-/-/30	17
K0299.110020	K0299.210020	K0299.310020	K0299.410020	M10	17	20	16	-/-/30/-	17
K0299.110040	K0299.210040	K0299.310040	K0299.410040	M10	17	40	16	-/-/30/-	17
K0299.112010	K0299.212010	K0299.312010	-	M12	19	10	20	-/-/40	19
K0299.112025	K0299.212025	K0299.312025	K0299.412025	M12	19	25	20	-/-/35/-	19
K0299.112050	K0299.212050	K0299.312050	K0299.412050	M12	19	50	20	-/-/35/-	19
K0299.116015	K0299.216015	K0299.316015	-	M16	27	15	24	-/-/50	27
K0299.116030	K0299.216030	K0299.316030	K0299.416030	M16	27	30	24	-/-/50/-	27
K0299.116060	K0299.216060	K0299.316060	K0299.416060	M16	27	60	24	-/-/50/-	27
K0299.120040	K0299.220040	K0299.320040	K0299.420040	M20	32	40	29	-/-/60/-	32
K0299.120080	K0299.220080	K0299.320080	K0299.420080	M20	32	80	29	-/-/60/-	32



## Fixture feet

with external thread

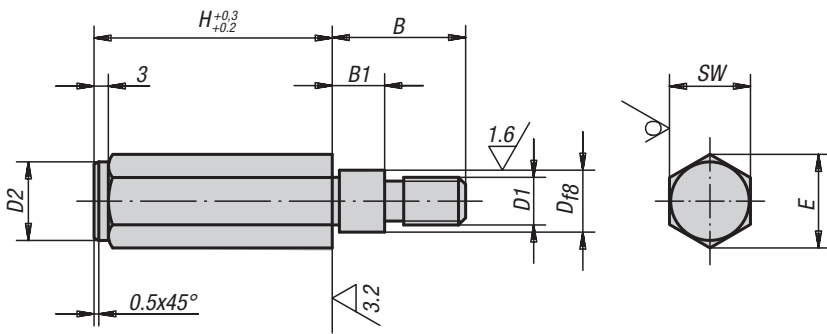

**Material:**  
Carbon steel 1.1181.

**Version:**  
Black oxidised.

**Sample order:**  
K0300.10X75 (include height H.)

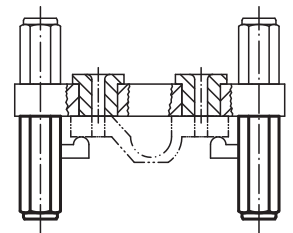

### KIPP Fixture feet with external thread

Order No.	H	B	B1	D	D1	D2	E	SW
K0300.10X	50/75/100	28	11	11	M10	16,5	19,5	17
K0300.12X	50/75/100/125	35	18	13	M12	18,5	21,5	19

## Application of a drilling jig

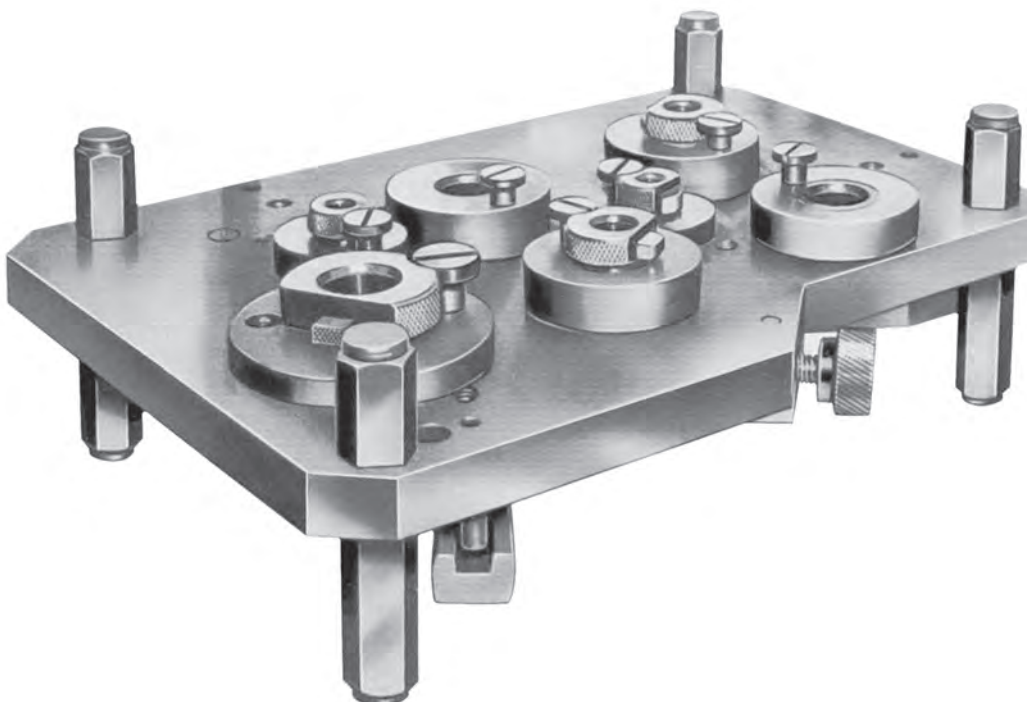

## Fixture feet

with internal thread



Form A  
flat face hardened

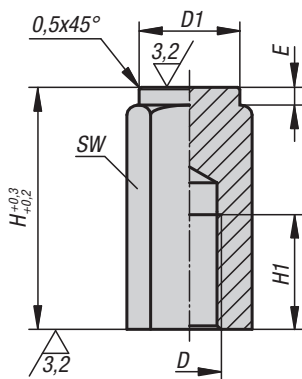

Form B  
flat face hardened  
and ground

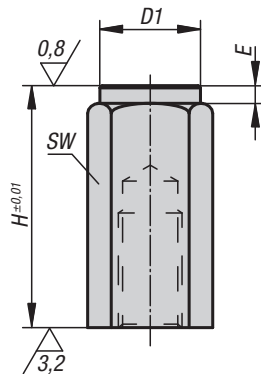

Form C  
convex face hardened

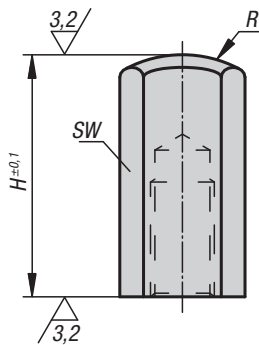

Form D  
diamond grip tempered

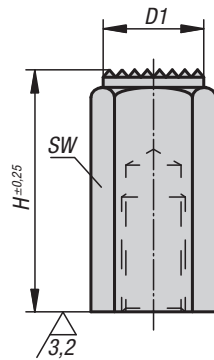

**Material:**

Body carbon steel.

**Version:**

Body tempered and black oxidised.  
Contact faces case-hardened.

**Sample order:**

K0301.106X20

**Note:**

Fixture feet with internal thread are used as supports for fixtures or rough or machined workpieces. They can also be used as stops or thrust pads in fixtures and toolmaking.

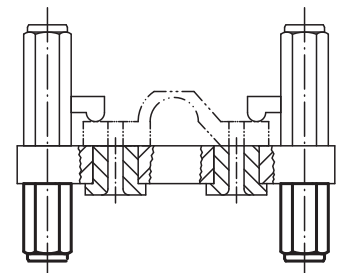

### KIPP Fixture feet with internal thread

Order No. Form A	Order No. Form B	Order No. Form C	Order No. Form D	D	D1	E	H	H1	R	SW
K0301.106X20	K0301.206X20	K0301.306X20	K0301.406X20	M6	9,5/9,5/-/9,5	2/2/-/	20	12	-/-/15/-	10
K0301.106X40	K0301.206X40	K0301.306X40	K0301.406X40	M6	9,5/9,5/-/9,5	2/2/-/	40	12	-/-/15/-	10
K0301.110X32	K0301.210X32	K0301.310X32	K0301.410X32	M10	16,5/16,5/-/16,5	3/3/-/	32	18	-/-/30/-	17
K0301.110X63	K0301.210X63	K0301.310X63	K0301.410X63	M10	16,5/16,5/-/16,5	3/3/-/	63	18	-/-/30/-	17
K0301.112X32	K0301.212X32	K0301.312X32	K0301.412X32	M12	18,5/18,5/-/18,5	3/3/-/	32	18	-/-/35/-	19
K0301.112X63	K0301.212X63	K0301.312X63	K0301.412X63	M12	18,5/18,5/-/18,5	3/3/-/	63	18	-/-/35/-	19
K0301.116X50	K0301.216X50	K0301.316X50	K0301.416X50	M16	23/23/-/23	4/4/-/	50	24	-/-/40/-	24
K0301.116X100	K0301.216X100	K0301.316X100	K0301.416X100	M16	23/23/-/23	4/4/-/	100	24	-/-/40/-	24



Form A  
smooth

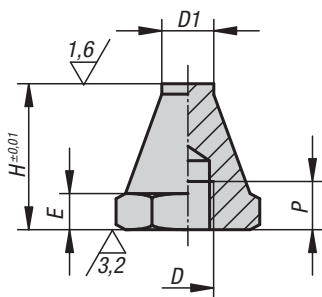

Form B  
spherical

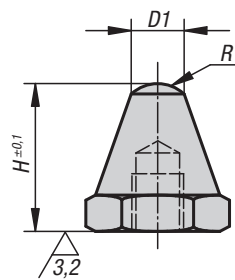

Form C  
serrated

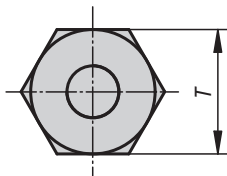
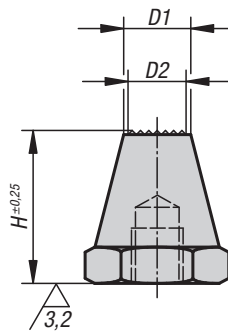

**Material:**  
Body carbon steel.

**Version:**  
Body tempered and black oxidised.

**Sample order:**  
K0294.106012

**Note:**  
Rest pads are for supporting machined and non-machined parts. They can also be used as stops and thrust pads in fixtures and toolmaking. Studs or grub screws can be screwed and glued into the tapped hole D to make a rest pad with external thread.

### KIPP Rest pads

Order No. Form A	Order No. Form B	Order No. Form C	D	D1	D2	E	H	P	R	T
K0294.106012	K0294.206012	K0294.306012	M6	6	-/-/5	3	12,5	4	-/5/-	11
K0294.106025	K0294.206025	K0294.306025	M6	6	-/-/5	3	25	7	-/5/-	11
K0294.108015	K0294.208015	K0294.308015	M8	8	-/-/6	4	15	6	-/8,5/-	13
K0294.108030	K0294.208030	K0294.308030	M8	8	-/-/6	4	30	9	-/8,5/-	13
K0294.110020	K0294.210020	K0294.310020	M10	10	-/-/8	5	20	9	-/9/-	17
K0294.110040	K0294.210040	K0294.310040	M10	10	-/-/8	5	40	13	-/9/-	17
K0294.112025	K0294.212025	K0294.312025	M12	12	-/-/9,5	6	25	11	-/12,75/-	19
K0294.112050	K0294.212050	K0294.312050	M12	12	-/-/9,5	6	50	16	-/12,75/-	19
K0294.116030	K0294.216030	K0294.316030	M16	16	-/-/13	8	30	12	-/17/-	24
K0294.116060	K0294.216060	K0294.316060	M16	16	-/-/13	8	60	20	-/17/-	24

## Rest pads

with positioning pin

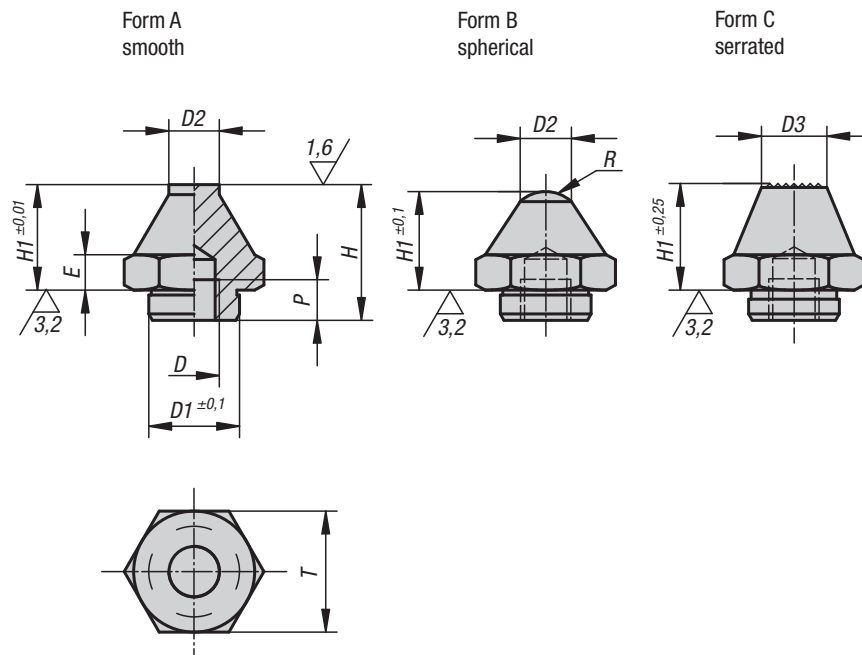

**Material:**  
Body carbon steel.

**Version:**  
Body tempered and black oxidised.  
Contact faces case-hardened.

**Sample order:**  
K0295.106012

**Note:**  
Rest pads are for supporting machined and unmachined parts. They can also be used as stops and thrust pads in fixtures and toolmaking. Studs or grub screws can be screwed and glued into the tapped hole D to make a support with external thread.

### KIPP Rest pads with positioning pin

Order No.	Form	D	D1	D2	D3	E	H	H1	P	R	T
K0295.106012	A	M6	11,9	7	-	4	16,5	12,5	6	-	17
K0295.106025	A	M6	11,9	7	-	4	29	25	6	-	17
K0295.110020	A	M10	17,8	10	-	7	25	20	10	-	24
K0295.110040	A	M10	17,8	10	-	7	46	40	10	-	24
K0295.116030	A	M16	25,8	20	-	13	40	30	16	-	41
K0295.116060	A	M16	25,8	20	-	13	70	60	16	-	41
K0295.206012	B	M6	11,9	7	-	4	16,5	12,5	6	6	17
K0295.206025	B	M6	11,9	7	-	4	29	25	6	6	17
K0295.210020	B	M10	17,8	10	-	7	25	20	10	7,5	24
K0295.210040	B	M10	17,8	10	-	7	46	40	10	7,5	24
K0295.216030	B	M16	25,8	20	-	13	40	30	16	26	41
K0295.216060	B	M16	25,8	20	-	13	70	60	16	26	41
K0295.310020	C	M10	17,8	-	15	7	25	20	10	-	24
K0295.310040	C	M10	17,8	-	10	7	46	40	10	-	24
K0295.316030	C	M16	25,8	-	20	13	40	30	16	-	41
K0295.316060	C	M16	25,8	-	20	13	70	60	16	-	41

## Feet

with threaded pin, DIN 6320 (edition 1971)



Form A  
with smooth  
support surface

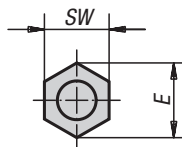
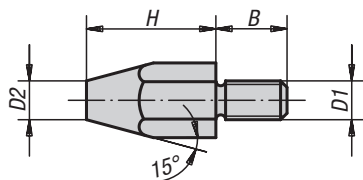

Form B  
with carbide tips

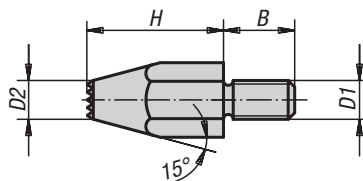

**Material:**

Carbon steel 1.1172.

**Version:**

Black oxidised.

**Sample order:**

K0296.10

**Note:**

The rest pads K0292 and K0293 can also be used as feet.

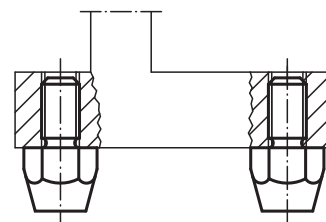

### KIPP Feet with threaded pin, DIN 6320 (edition 1971)

Order No.	Form	D1	D2	H	B	E	SW
K0296.06	A	M6	8	10	11	11,5	10
K0296.061	A	M6	6	20	11	11,5	10
K0296.08	A	M8	10	15	13	15	13
K0296.081	A	M8	9	30	13	15	13
K0296.10	A	M10	13	20	16	19,6	17
K0296.101	A	M10	13	40	16	19,6	17
K0296.12	A	M12	15	25	20	21,9	19
K0296.121	A	M12	15	50	20	21,9	19
K0296.083	B	M8	11,5	15	13	15	13
K0296.123	B	M12	15	25	20	21,9	19

## Locating feet



**Material:**  
Steel 1.0301.

**Version:**  
Case-hardened and black oxidised.

**Sample order:**  
K0303.08

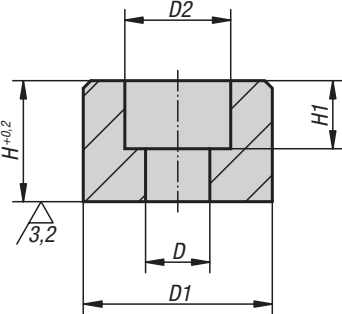

### KIPP Locating feet

Order No.	D	D1	D2	H	H1
K0303.05	5,5	16	10	10	5,7
K0303.06	6,6	20	11	12	7
K0303.08	9	25	15	16	9
K0303.10	11	32	18	20	11
K0303.12	13,5	36	20	25	13

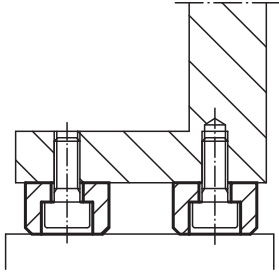

## Notes

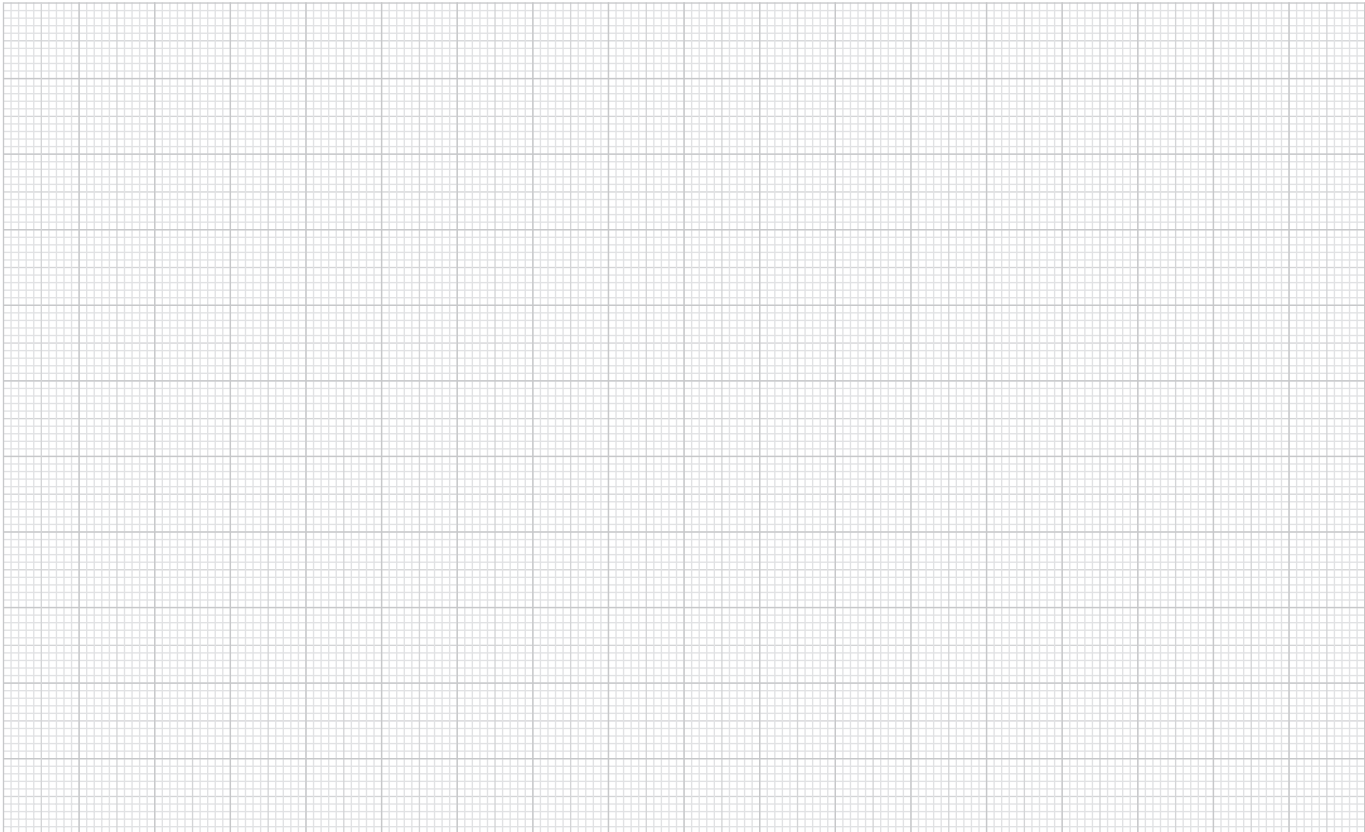

## Support bolts



**Material:**  
Tempered steel.

**Version:**  
Black oxidised.

**Sample order:**  
K0297.16016

**Note:**  
The rounded nose also allows support bolts to be used as positioning elements for workpieces with matching holes.

The version K0297.08016 has a hex collar.

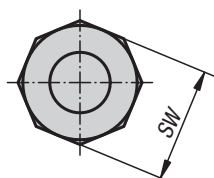
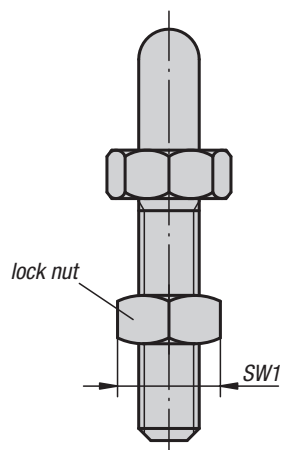
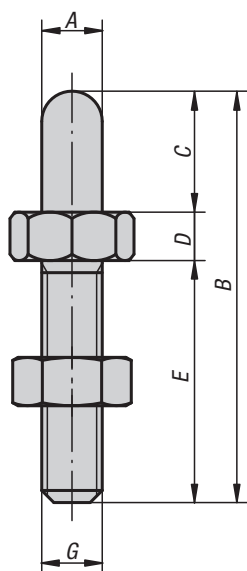

### KIPP Support bolts

Order No.	A	B	C	D	E	G	SW	SW1
K0297.06006	6	37	6	6	25	M6	13	10
K0297.06012	6	43	12	6	25	M6	13	10
K0297.08008	8	45	8	7	30	M8	13	13
K0297.08016	8	53	16	7	30	M8	13	13
K0297.10010	10	58	10	8	40	M10	17	17
K0297.10020	10	68	20	8	40	M10	17	17
K0297.12012	12	72	12	10	50	M12	19	19
K0297.12024	12	84	24	10	50	M12	19	19
K0297.16016	16	89	16	13	60	M16	24	24
K0297.16032	16	105	32	13	60	M16	24	24
K0297.20020	20	115	20	15	80	M20	36	30
K0297.20040	20	135	40	15	80	M20	36	30



# K0305

## Rest pads

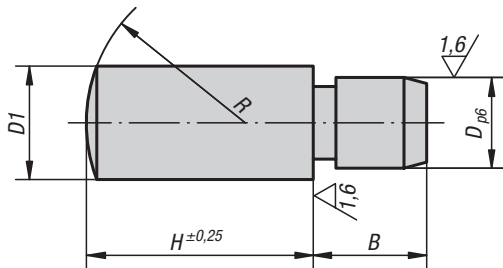

### KIPP Rest pads

Order No.	H	B	D	D1	R
K0305.05X	8/10/12/16	5	4	5	7
K0305.06X	10/12/16/20	6	5	6	8
K0305.08X	12/16/20/25	8	6	8	11
K0305.10X	16/20/25/32	10	8	10	14
K0305.12X	20/25/32/40	12	10	12	16
K0305.14X	20/25/32/40	14	12	14	20
K0305.16X	25/32/40/50	16	14	16	25
K0305.20X	25/32/40/50	20	16	20	28



**Material:**  
Steel 1.0301.

**Version:**  
Case-hardened, black oxidised and ground.

**Sample order:**  
K0305.05X8 (include length H)

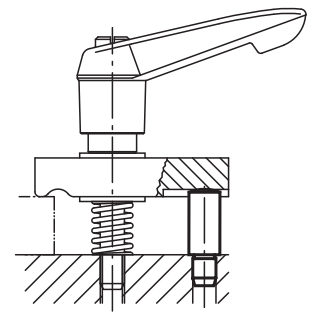

# K0306

## Rest pads adjustable

with locknut

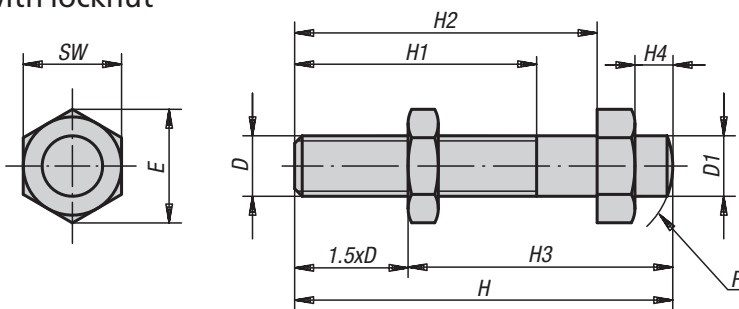

**Material:**  
Carbon steel 1.1181.

**Version:**  
Surface hardened, black oxidised.

**Sample order:**  
K0306.05

### KIPP Rest pads adjustable with locknut

Order No.	D	D1	H	H1	H2	H3 min.	H3 max.	H4	E	SW	R	F approx.N
K0306.05	M5	5	50	32	40	20,5	42,5	5	11,5	10	7	1000
K0306.06	M6	6	50	32	40	21	41	5	11,5	10	8	1430
K0306.08	M8	8	50	32	40	22	38	5	15	13	11	2620
K0306.10	M10	10	52	32	40	25	37	5	19,6	17	14	4180
K0306.101	M10	10	70	32	56	42	55	6	19,6	17	14	4180
K0306.12	M12	12	70	40	56	36	52	6	21,9	19	16	6100
K0306.121	M12	12	95	50	80	51	77	6	21,9	19	16	6100
K0306.14	M14	14	100	63	80	44	79	8	25,4	22	20	8320
K0306.16	M16	16	100	63	80	45	76	8	27,7	24	25	11520
K0306.161	M16	16	120	63	100	65	96	8	27,7	24	25	11520
K0306.20	M20	20	110	70	88	50	90	10	34,6	30	28	18000

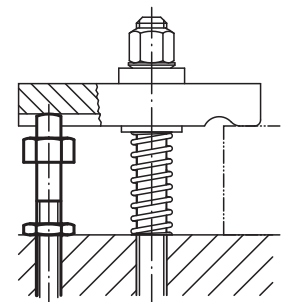



## Rest pads



**Material:**  
Carbon steel or brass

**Version:**  
Tempered and black oxidised.

**Sample order:**  
K0307.16055

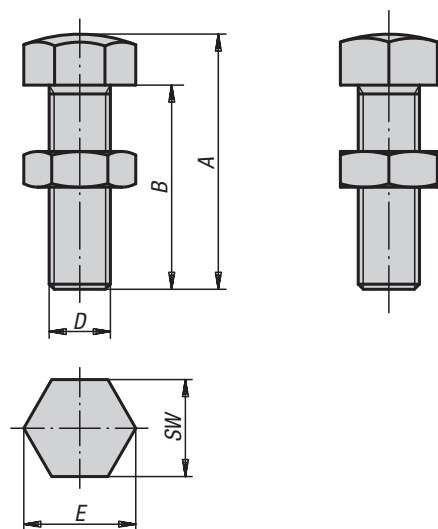

### KIPP Rest pads

Order No.	Material	A	B	D	E	SW
K0307.06030	tempered steel	30	25	M6	11,5	10
K0307.06040	tempered steel	40	35	M6	11,5	10
K0307.06050	tempered steel	50	45	M6	11,5	10
K0307.08036	tempered steel	36	30	M8	15	13
K0307.08046	tempered steel	46	40	M8	15	13
K0307.08056	tempered steel	56	50	M8	15	13
K0307.10042	tempered steel	42	35	M10	19,6	17
K0307.10048	tempered steel	48	40	M10	19,6	17
K0307.10058	tempered steel	58	50	M10	19,6	17
K0307.10068	tempered steel	68	60	M10	19,6	17
K0307.12048	tempered steel	50	42	M12	21,9	19
K0307.12070	tempered steel	70	60	M12	21,9	19
K0307.12080	tempered steel	80	70	M12	21,9	19
K0307.16055	tempered steel	55	45	M16	27,7	24
K0307.16075	tempered steel	75	65	M16	27,7	24
K0307.16085	tempered steel	85	75	M16	27,7	24
K0307.12148	brass	50	42	M12	21,9	19
K0307.16155	brass	55	45	M16	27,7	24

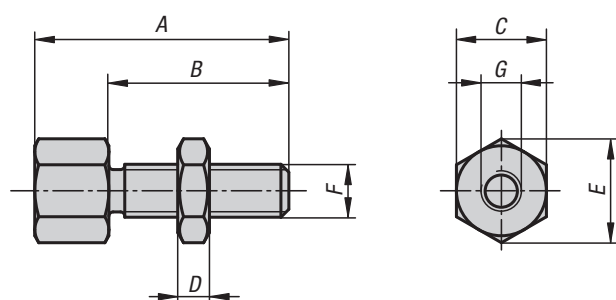

**Material:**  
Carbon steel.

**Version:**  
Black oxidised.

**Sample order:**  
K0308.0803006

Adjustable support, accepts various inserts.

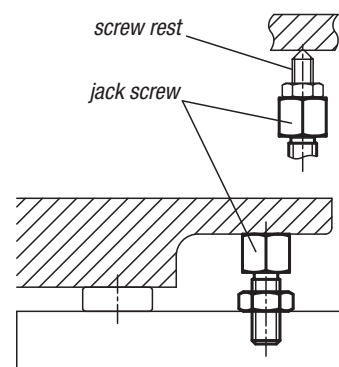

### KIPP Jack screws

Order No.	A	B	C	D	E	F	G
K0308.0803006	30	20	13	5	14,4	M8	M6x6
K0308.0804006	40	30	13	5	14,4	M8	M6x6
K0308.1003808	38	24	17	6	18,9	M10	M8x8
K0308.1004808	48	34	17	6	18,9	M10	M8x8
K0308.1205110	51	33	22	7	24,5	M12	M10x10
K0308.1206610	66	48	22	7	24,5	M12	M10x10
K0308.1606212	62	40	27	10	30,1	M16	M12x12
K0308.1607712	77	55	27	10	30,1	M16	M12x12

## Stop

adjustable, with end position feedback

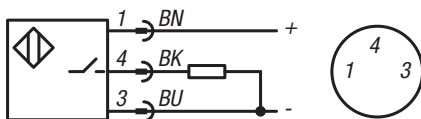
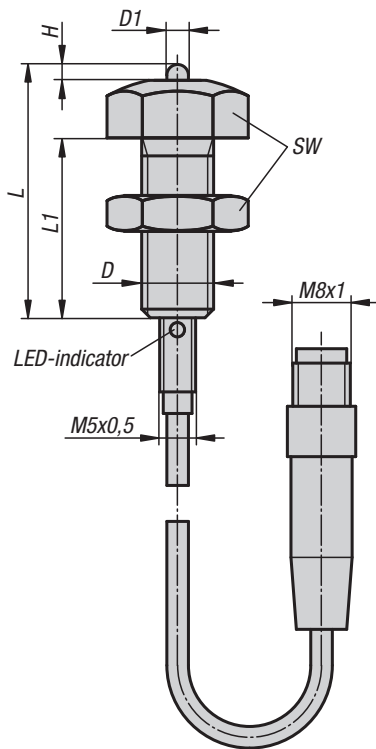

Connection diagram:

BN = brown  
BK = black  
BU = blue

### Material:

Screw and plunger stainless steel 1.4301  
Guide bush stainless steel 1.4112  
Sensor housing stainless steel.

### Version:

Screw and plunger, bright.  
Guide bushing, bright.  
Sensor housing, bright.  
Inductive sensor:  
Relay (NO)  
Operating voltage 10 - 30 V DC  
Operating current 100 mA  
Switching distance 0,8  
Protection class: IP 67  
Connection type: 0,3 m cable, PUR, with plug connector  
Temperature range: -25°C - +70°C  
Approval: CE, c-UL-us

### Sample order:

K0581.080352

### Note:

The ensured sensing distance is achieved if the plunger is actuated flush up to the stop surface of the guide bush. The sensor is supplied unassembled.

Installation recommendation: glue in with Loctite 638.

Caution: screw sensor in until it comes to a stop.

### Safety:

The use of adjustable stops is not suitable for protecting people.



## KIPP Stop, adjustable, with end position feedback

Order No.	Size	D	D1	H	L	L1	SW
K0581.080352	1	M8	3	2	35,2	25	13
K0581.100352	2	M10	3	2	35,2	25	17
K0581.120352	3	M12	3	2	35,2	25	19

# Spherical washers

DIN 6319, edition 10/01

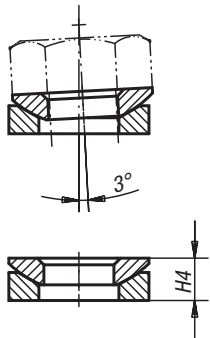

Form C  
spherical washer

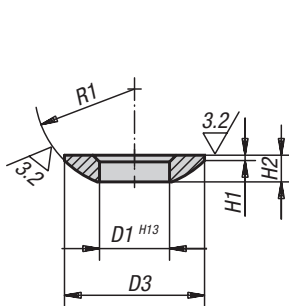

Form D conical seat  $D4 = D3$   
Form G conical seat  $D4 > D3$

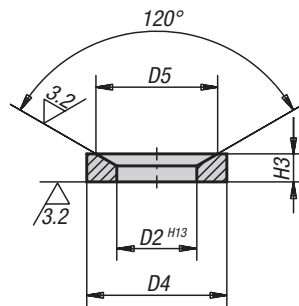

**Material:**

Mild steel or stainless steel.  
Form G carbon steel tempered to HV 390 ±40.

**Version:**

Steel version case hardened.  
Stainless steel version bright, not hardened.

**Sample order:**

K0729.216

**Note:**

Conical seat Form G should be used over slots.

## KIPP Spherical washers DIN 6319, edition 10/01

Order No. steel	Order No. stainless steel	Form	D1	D3	H1	H2	R1	for screw Ø	Load rating max. kN (static load only)
K0729.105	-	C	5,25	10,5	0,4	2	7,5	5	-
K0729.106	K0729.0106	C	6,4	12	0,7	2,3	9	6	9/6
K0729.108	K0729.0108	C	8,4	17	0,6	3,2	12	8	17/12
K0729.110	K0729.0110	C	10,5	21	0,8	4	15	10	26/16
K0729.112	K0729.0112	C	13	24	1,1	4,6	17	12	38/24
K0729.114	-	C	15	28	1,2	5	22	14	53
K0729.116	K0729.0116	C	17	30	1,3	5,3	22	16	73/45
K0729.120	K0729.0120	C	21	36	2	6,3	27	20	117/71
K0729.124	K0729.0124	C	25	44	2,4	8,2	32	24	168/105
K0729.130	K0729.0130	C	31	56	3,6	11,2	41	30	269/191
K0729.136	K0729.0136	C	37	68	4,6	14	50	36	394/-
K0729.142	K0729.0142	C	43	78	6,5	17	58	42	542/-
K0729.148	K0729.0148	C	50	92	8	21	67	48	714/-
K0729.156	-	C	58	103	9,5	23	79	56	-
K0729.164	-	C	66	120	12	27	93	64	-

## Spherical washers

DIN 6319, edition 10/01



Order No. steel	Order No. stainless steel	Form	D2	D4	D5	H3	H4 with conical seat	for screw Ø	Load rating max. kN (static load only)
K0729.205	-	D	6	10,5	9,25	2,1	3,1	5	-
K0729.206	K0729.0206	D	7,1	12	11	2,8	4	6	9/6
K0729.208	K0729.0208	D	9,6	17	14,5	3,5	5,6	8	17/12
K0729.210	K0729.0210	D	12	21	18,5	4,2	6,3	10	26/16
K0729.212	K0729.0212	D	14,2	24	20	5	8	12	38/24
K0729.214	-	D	16,5	28	24,8	5,6	8,2	14	53
K0729.216	K0729.0216	D	19	30	26	6,2	9,3	16	73/45
K0729.220	K0729.0220	D	23,2	36	31	7,5	11,6	20	117/71
K0729.224	K0729.0224	D	28	44	37	9,5	15	24	168/105
K0729.230	K0729.0230	D	35	56	49	12	18,9	30	269/191
K0729.236	K0729.0236	D	42	68	60	15	23,3	36	394/-
K0729.242	K0729.0242	D	49	78	70	18	28,3	42	542/-
K0729.248	K0729.0248	D	56	92	82	22	35,2	48	714/-
K0729.256	-	D	65	103	92	25	39,7	56	-
K0729.264	-	D	75	120	110	30	46,5	64	-
K0729.305	-	G	6	15	9,25	2,5	3,5	5	-
K0729.306	K0729.0306	G	7,1	17	11	4	5,2	6	9/6
K0729.308	K0729.0308	G	9,6	24	14,5	5	6,8	8	17/12
K0729.310	K0729.0310	G	12	30	18,5	5	7,1	10	26/16
K0729.312	K0729.0312	G	14,2	36	20	6	9	12	38/24
K0729.314	-	G	16,5	40	24,8	6	8,6	14	53
K0729.316	K0729.0316	G	19	44	26	7	10,1	16	73/45
K0729.320	K0729.0320	G	23,2	50	31	8	12	20	117/71
K0729.324	K0729.0324	G	28	60	37	10	15,5	24	168/105
K0729.330	K0729.0330	G	35	68	49	12	18,7	30	269/191
K0729.336	-	G	42	80	60	12	20,3	36	394/-



## Spherical levelling washers

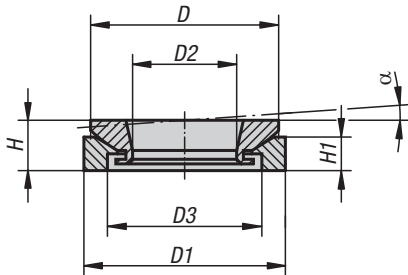

**Material:**

Steel 1.7225.  
Stainless steel 1.4305.

**Version:**

Steel blue-chromed.  
Stainless steel bright.

**Sample order:**

K0691.401

**Note:**

Spherical levelling washers are for exact positioning when mounting up to 4° sloping surfaces. A second spherical levelling washer is recommended as support to correct the bolt angle if the angle of D3 is > 1°. The two washers cannot be detached from each other.

application example:

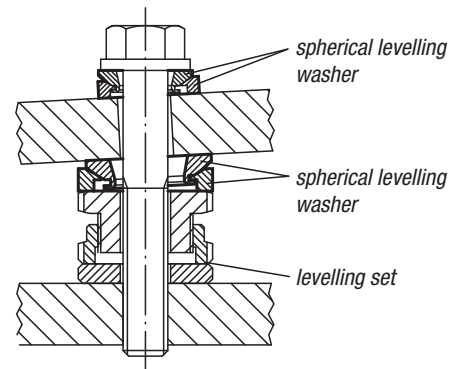

### KIPP Spherical levelling washers

Order No. steel	Order No. stainless steel	H	H1	D	D1	D2	D3	α
K0691.151	K0691.152	8	5,5	23	25	8,5	15	4°
K0691.201	K0691.202	10	6,2	30	32	13	20	4°
K0691.301	K0691.302	12,5	9	40	45	20	30	4°
K0691.401	K0691.402	16	13	52	58	29	38	4°
K0691.501	K0691.502	20	14	65	70	36	48	4°

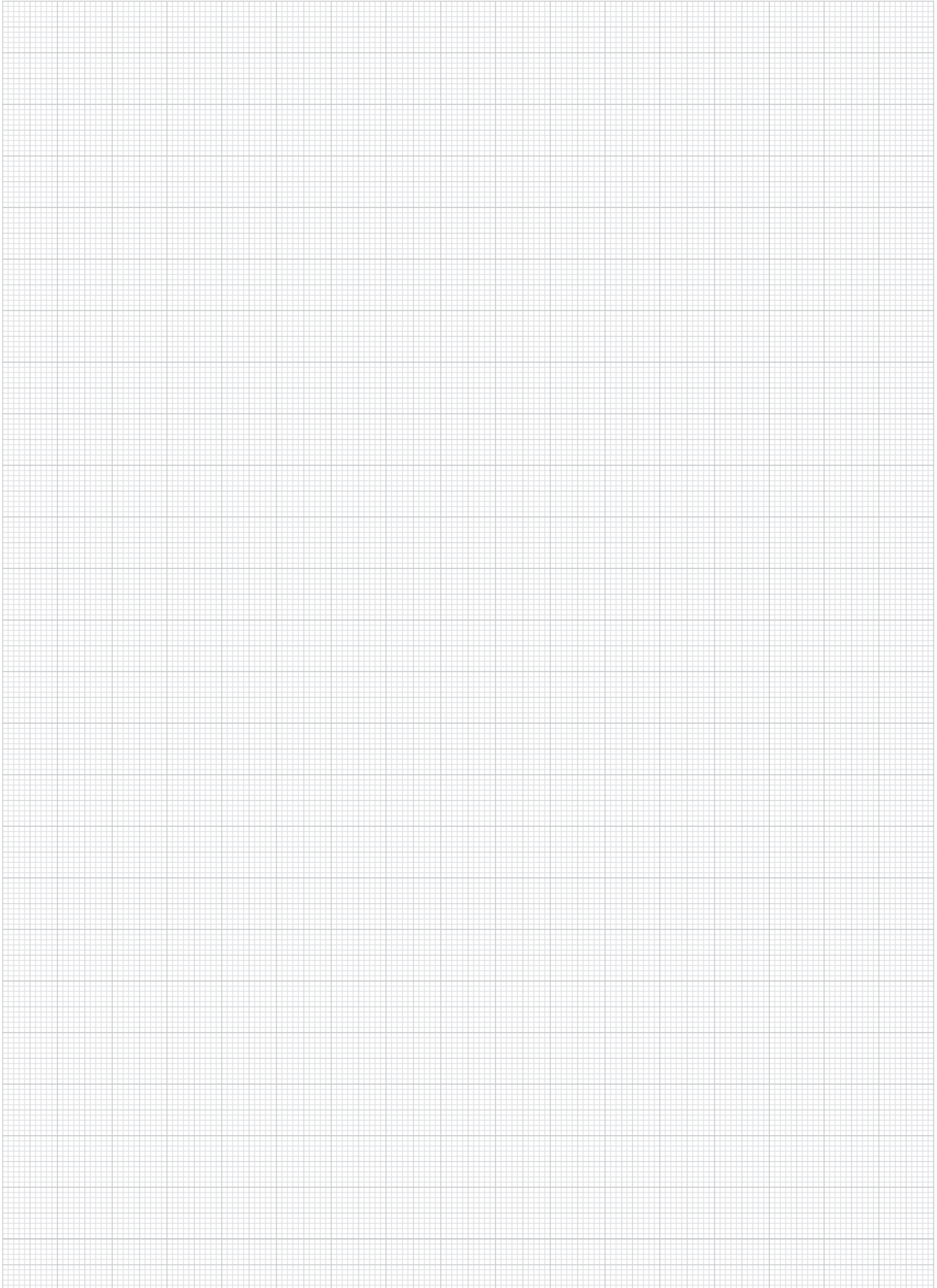

## Levelling sets

high version

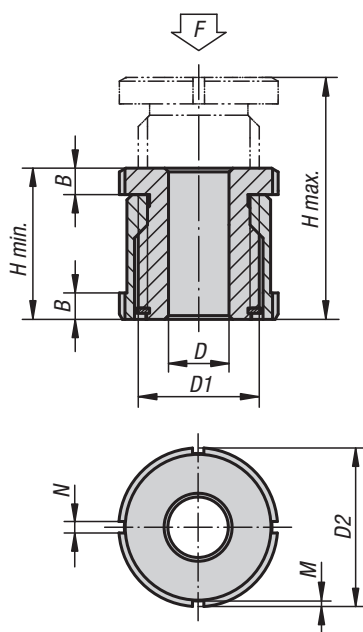

**Material:**  
Steel 1.7225.  
Stainless steel 1.4305.

**Version:**  
Steel zinc plated, blue chromed.  
Stainless steel bright.

**Sample order:**  
K0692.01505

**Note:**  
Levelling sets are used for mounting, levelling and aligning motors, aggregates, drive units and assembly lines. They have a large adjustment range of 15 mm to 40 mm. Other sizes available on request.

### KIPP Levelling sets, high version

Order No.	Material	D	for screw	D1	D2	H min.	H max.	B	N	M	F kN
K0692.01504	steel	4,5	M4	M15x1	25	28	43	5	4	2	40
K0692.01505	steel	5,5	M5	M15x1	25	28	43	5	4	2	40
K0692.01506	steel	6,6	M6	M15x1	25	28	43	5	4	2	40
K0692.02006	steel	6,6	M6	M20x1	32	35	55	6	4	2	65
K0692.02008	steel	9	M8	M20x1	32	35	55	6	4	2	65
K0692.02010	steel	11	M10	M20x1	32	35	55	6	4	2	65
K0692.02510	steel	11	M10	M30x1,5	45	42	67	7	5	2	120
K0692.02512	steel	13,5	M12	M30x1,5	45	42	67	7	5	2	120
K0692.02516	steel	17,5	M16	M30x1,5	45	42	67	7	5	2	120
K0692.03216	steel	17,5	M16	M40x1,5	58	54	86	9	6	2,5	210
K0692.03220	steel	22	M20	M40x1,5	58	54	86	9	6	2,5	210
K0692.03224	steel	26	M24	M40x1,5	58	54	86	9	6	2,5	210
K0692.04020	steel	22	M20	M50x1,5	70	66	106	11	6	2,5	330
K0692.04024	steel	26	M24	M50x1,5	70	66	106	11	6	2,5	330
K0692.04030	steel	33	M30	M50x1,5	70	66	106	11	6	2,5	330
K0692.015041	stainless steel	4,5	M4	M15x1	25	28	43	5	4	2	27,1
K0692.015051	stainless steel	5,5	M5	M15x1	25	28	43	5	4	2	27,1
K0692.015061	stainless steel	6,6	M6	M15x1	25	28	43	5	4	2	27,1
K0692.020061	stainless steel	6,6	M6	M20x1	32	35	55	6	4	2	43,4
K0692.020081	stainless steel	9	M8	M20x1	32	35	55	6	4	2	43,4
K0692.020101	stainless steel	11	M10	M20x1	32	35	55	6	4	2	43,4
K0692.025101	stainless steel	11	M10	M30x1,5	45	42	67	7	5	2	84
K0692.025121	stainless steel	13,5	M12	M30x1,5	45	42	67	7	5	2	84
K0692.025161	stainless steel	17,5	M16	M30x1,5	45	42	67	7	5	2	84
K0692.032161	stainless steel	17,5	M16	M40x1,5	58	54	86	9	6	2,5	148
K0692.032201	stainless steel	22	M20	M40x1,5	58	54	86	9	6	2,5	148
K0692.032241	stainless steel	26	M24	M40x1,5	58	54	86	9	6	2,5	148
K0692.040201	stainless steel	22	M20	M50x1,5	70	66	106	11	6	2,5	225
K0692.040241	stainless steel	26	M24	M50x1,5	70	66	106	11	6	2,5	225
K0692.040301	stainless steel	33	M30	M50x1,5	70	66	106	11	6	2,5	225

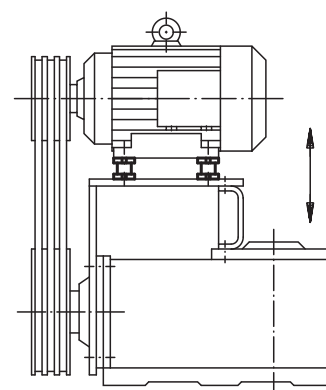



## Levelling sets

with locknut



**Material:**  
Steel 1.7225.  
Stainless steel 1.4305.

**Version:**  
Steel zinc plated, blue chromed.  
Stainless steel bright.

**Sample order:**  
K0693.01004

**Note:**  
Levelling sets are used for mounting, levelling and aligning motors, aggregates, drive units and assembly lines. The locknut locks the set height. Other sizes available on request.

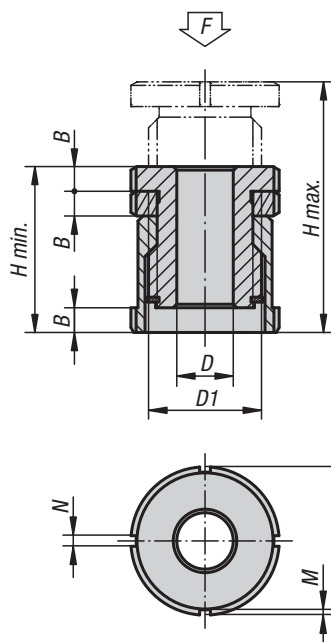

### KIPP Levelling sets, with locknut

Order No.	Material	D	for screw	D1	D2	H min.	H max.	B	N	M	F kN
K0693.01004	steel	4,5	M4	M15x1	25	33	43	5	4	2	40
K0693.01005	steel	5,5	M5	M15x1	25	33	43	5	4	2	40
K0693.01006	steel	6,6	M6	M15x1	25	33	43	5	4	2	40
K0693.01406	steel	6,6	M6	M20x1	32	41	55	6	4	2	65
K0693.01408	steel	9	M8	M20x1	32	41	55	6	4	2	65
K0693.01410	steel	11	M10	M20x1	32	41	55	6	4	2	65
K0693.01810	steel	11	M10	M30x1,5	45	49	67	7	5	2	120
K0693.01812	steel	13,5	M12	M30x1,5	45	49	67	7	5	2	120
K0693.01816	steel	17,5	M16	M30x1,5	45	49	67	7	5	2	120
K0693.02316	steel	17,5	M16	M40x1,5	58	63	86	9	6	2,5	210
K0693.02320	steel	22	M20	M40x1,5	58	63	86	9	6	2,5	210
K0693.02324	steel	26	M24	M40x1,5	58	63	86	9	6	2,5	210
K0693.02920	steel	22	M20	M50x1,5	70	77	106	11	6	2,5	330
K0693.02924	steel	26	M24	M50x1,5	70	77	106	11	6	2,5	330
K0693.02930	steel	33	M30	M50x1,5	70	77	106	11	6	2,5	330
K0693.010041	stainless steel	4,5	M4	M15x1	25	33	43	5	4	2	27,1
K0693.010051	stainless steel	5,5	M5	M15x1	25	33	43	5	4	2	27,1
K0693.010061	stainless steel	6,6	M6	M15x1	25	33	43	5	4	2	27,1
K0693.014061	stainless steel	6,6	M6	M20x1	32	41	55	6	4	2	43,4
K0693.014081	stainless steel	9	M8	M20x1	32	41	55	6	4	2	43,4
K0693.014101	stainless steel	11	M10	M20x1	32	41	55	6	4	2	43,4
K0693.018101	stainless steel	11	M10	M30x1,5	45	49	67	7	5	2	84
K0693.018121	stainless steel	13,5	M12	M30x1,5	45	49	67	7	5	2	84
K0693.018161	stainless steel	17,5	M16	M30x1,5	45	49	67	7	5	2	84
K0693.023161	stainless steel	17,5	M16	M40x1,5	58	63	86	9	6	2,5	148
K0693.023201	stainless steel	22	M20	M40x1,5	58	63	86	9	6	2,5	148
K0693.023241	stainless steel	26	M24	M40x1,5	58	63	86	9	6	2,5	148
K0693.029201	stainless steel	22	M20	M50x1,5	70	77	106	11	6	2,5	225
K0693.029241	stainless steel	26	M24	M50x1,5	70	77	106	11	6	2,5	225
K0693.029301	stainless steel	33	M30	M50x1,5	70	77	106	11	6	2,5	225

## Levelling sets

low version



**Material:**  
Steel 1.7225.  
Stainless steel 1.4305.

**Version:**  
Steel zinc plated, blue chromed.  
Stainless steel bright.

**Sample order:**  
K0694.0404

**Note:**  
Levelling sets are used for mounting, levelling and aligning motors, aggregates, drive units and assembly lines. This levelling set has an extremely low height. Single levelling sets can be set at several mounting points to achieve a precise and torsion-free alignment.

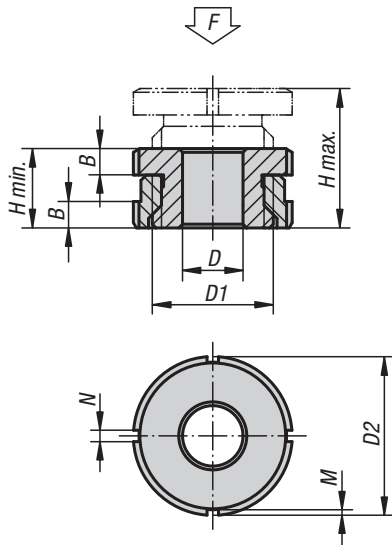

### KIPP Levelling sets, low version

Order No.	Material	D	for screw	D1	D2	H min.	H max.	B	N	M	F kN
K0694.0404	steel	4,5	M4	M15x1	25	15	19	5	4	2	40
K0694.0405	steel	5,5	M5	M15x1	25	15	19	5	4	2	40
K0694.0406	steel	6,6	M6	M15x1	25	15	19	5	4	2	40
K0694.0506	steel	6,6	M6	M20x1	32	18	23	6	4	2	65
K0694.0508	steel	9	M8	M20x1	32	18	23	6	4	2	65
K0694.0510	steel	11	M10	M20x1	32	18	23	6	4	2	65
K0694.0710	steel	11	M10	M30x1,5	45	22	29	7	5	2	120
K0694.0712	steel	13,5	M12	M30x1,5	45	22	29	7	5	2	120
K0694.0716	steel	17,5	M16	M30x1,5	45	22	29	7	5	2	120
K0694.0916	steel	17,5	M16	M40x1,5	58	28	37	9	6	2,5	210
K0694.0920	steel	22	M20	M40x1,5	58	28	37	9	6	2,5	210
K0694.0924	steel	26	M24	M40x1,5	58	28	37	9	6	2,5	210
K0694.1020	steel	22	M20	M50x1,5	70	33	43	11	6	2,5	330
K0694.1024	steel	26	M24	M50x1,5	70	33	43	11	6	2,5	330
K0694.1030	steel	33	M30	M50x1,5	70	33	43	11	6	2,5	330
K0694.04041	stainless steel	4,5	M4	M15x1	25	15	19	5	4	2	27,1
K0694.04051	stainless steel	5,5	M5	M15x1	25	15	19	5	4	2	27,1
K0694.04061	stainless steel	6,6	M6	M15x1	25	15	19	5	4	2	27,1
K0694.05061	stainless steel	6,6	M6	M20x1	32	18	23	6	4	2	43,4
K0694.05081	stainless steel	9	M8	M20x1	32	18	23	6	4	2	43,4
K0694.05101	stainless steel	11	M10	M20x1	32	18	23	6	4	2	43,4
K0694.07101	stainless steel	11	M10	M30x1,5	45	22	29	7	5	2	84
K0694.07121	stainless steel	13,5	M12	M30x1,5	45	22	29	7	5	2	84
K0694.07161	stainless steel	17,5	M16	M30x1,5	45	22	29	7	5	2	84
K0694.09161	stainless steel	17,5	M16	M40x1,5	58	28	37	9	6	2,5	148
K0694.09201	stainless steel	22	M20	M40x1,5	58	28	37	9	6	2,5	148
K0694.09241	stainless steel	26	M24	M40x1,5	58	28	37	9	6	2,5	148
K0694.10201	stainless steel	22	M20	M50x1,5	70	33	43	11	6	2,5	225
K0694.10241	stainless steel	26	M24	M50x1,5	70	33	43	11	6	2,5	225
K0694.10301	stainless steel	33	M30	M50x1,5	70	33	43	11	6	2,5	225

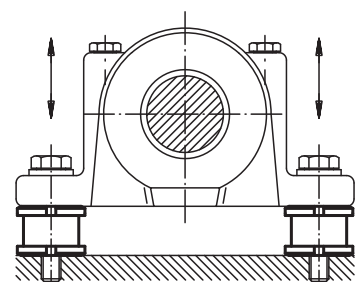

## Levelling sets

spherical washer

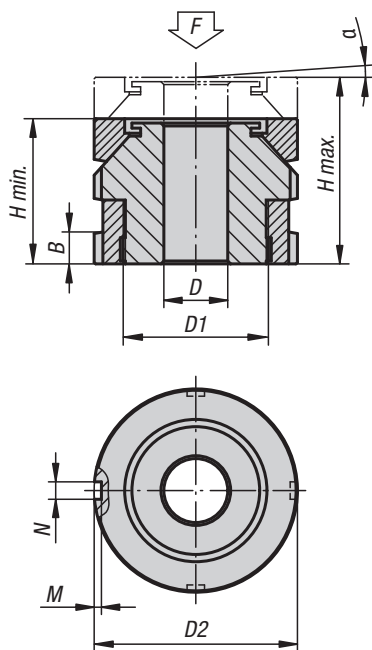

**Material:**

Steel 1.7225.  
Stainless steel 1.4305.

**Version:**

Steel zinc plated, blue chromed.  
Stainless steel bright.

**Sample order:**

K0695.0406

**Note:**

Levelling sets with spherical washers are used for mounting, levelling and aligning motors, aggregates, drive units and assembly lines. The spherical washer permits exact alignment when mounting sloping surfaces of up to 4°.

### KIPP Levelling sets, spherical washer

Order No.	Material	D	for screw	D1	D2	H min.	H max.	B	N	M	α	F kN
K0695.0406	steel	6,6	M6	M15x1	25	22	26	5	4	2	4°	40
K0695.0506	steel	6,6	M6	M20x1	32	26	31	6	4	2	4°	65
K0695.0508	steel	9	M8	M20x1	32	26	31	6	4	2	4°	65
K0695.0510	steel	11	M10	M20x1	32	26	31	6	4	2	4°	65
K0695.0710	steel	11	M10	M30x1,5	45	34	41	7	5	2	4°	120
K0695.0712	steel	13,5	M12	M30x1,5	45	34	41	7	5	2	4°	120
K0695.0716	steel	17,5	M16	M30x1,5	45	34	41	7	5	2	4°	120
K0695.0916	steel	17,5	M16	M40x1,5	58	44	53	9	6	2,5	4°	210
K0695.0920	steel	22	M20	M40x1,5	58	44	53	9	6	2,5	4°	210
K0695.0924	steel	26	M24	M40x1,5	58	44	53	9	6	2,5	4°	210
K0695.1020	steel	22	M20	M50x1,5	70	50	60	11	6	2,5	4°	330
K0695.1024	steel	26	M24	M50x1,5	70	50	60	11	6	2,5	4°	330
K0695.1030	steel	33	M30	M50x1,5	70	50	60	11	6	2,5	4°	330
K0695.1224	steel	26	M24	M60x2	80	56	68	11	7	3	4°	495
K0695.1230	steel	33	M30	M60x2	80	56	68	11	7	3	4°	495
K0695.04061	stainless steel	6,6	M6	M15x1	25	22	26	5	4	2	4°	27,1
K0695.05061	stainless steel	6,6	M6	M20x1	32	26	31	6	4	2	4°	43,4
K0695.05081	stainless steel	9	M8	M20x1	32	26	31	6	4	2	4°	43,4
K0695.05101	stainless steel	11	M10	M20x1	32	26	31	6	4	2	4°	43,4
K0695.07101	stainless steel	11	M10	M30x1,5	45	34	41	7	5	2	4°	84
K0695.07121	stainless steel	13,5	M12	M30x1,5	45	34	41	7	5	2	4°	84
K0695.07161	stainless steel	17,5	M16	M30x1,5	45	34	41	7	5	2	4°	84
K0695.09161	stainless steel	17,5	M16	M40x1,5	58	44	53	9	6	2,5	4°	148
K0695.09201	stainless steel	22	M20	M40x1,5	58	44	53	9	6	2,5	4°	148
K0695.09241	stainless steel	26	M24	M40x1,5	58	44	53	9	6	2,5	4°	148
K0695.10201	stainless steel	22	M20	M50x1,5	70	50	60	11	6	2,5	4°	225
K0695.10241	stainless steel	26	M24	M50x1,5	70	50	60	11	6	2,5	4°	225
K0695.10301	stainless steel	33	M30	M50x1,5	70	50	60	11	6	2,5	4°	225
K0695.12241	stainless steel	26	M24	M60x2	80	56	68	11	7	3	4°	323
K0695.12301	stainless steel	33	M30	M60x2	80	56	68	11	7	3	4°	323



# Levelling sets

with locknut



**Material:**

Steel 1.7225.

Stainless steel 1.4305.

**Version:**

Standard version galvanized, blue chromed.

Stainless steel version bright.

**Sample order:**

K0097.0404

**Note:**

These low version levelling sets with locknut are used to mount and align motors, aggregates, drive units and production lines. The advantage is the low height. Alignments can be made quickly and easily even with several levelling points. Distortion-free mounting is guaranteed. The locknut secures a prescribed adjustment.

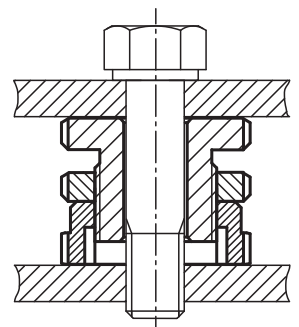
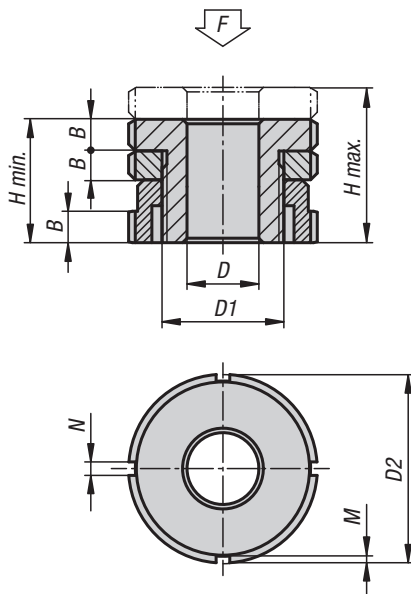

# Levelling sets

with locknut



## KIPP Levelling sets with locknut

Order No.	Material	D	for screw	D1	D2	H min.	H max.	B	N	M	F kN
K0097.0404	steel	4,5	M4	M15x1	25	20	24	5	4	2	40
K0097.0405	steel	5,5	M5	M15x1	25	20	24	5	4	2	40
K0097.0406	steel	6,6	M6	M15x1	25	20	24	5	4	2	40
K0097.0506	steel	6,6	M6	M20x1	32	24	29	6	4	2	65
K0097.0508	steel	9	M8	M20x1	32	24	29	6	4	2	65
K0097.0510	steel	11	M10	M20x1	32	24	29	6	4	2	65
K0097.0710	steel	11	M10	M30x1,5	45	29	36	7	5	2	120
K0097.0712	steel	13,5	M12	M30x1,5	45	29	36	7	5	2	120
K0097.0716	steel	17,5	M16	M30x1,5	45	29	36	7	5	2	120
K0097.0916	steel	17,5	M16	M40x1,5	58	37	46	9	6	2,5	210
K0097.0920	steel	22	M20	M40x1,5	58	37	46	9	6	2,5	210
K0097.0924	steel	26	M24	M40x1,5	58	37	46	9	6	2,5	210
K0097.1020	steel	22	M20	M50x1,5	70	44	54	11	6	2,5	330
K0097.1024	steel	26	M24	M50x1,5	70	44	54	11	6	2,5	330
K0097.1030	steel	33	M30	M50x1,5	70	44	54	11	6	2,5	330
K0097.04041	stainless steel	4,5	M4	M15x1	25	20	24	5	4	2	27,1
K0097.04051	stainless steel	5,5	M5	M15x1	25	20	24	5	4	2	27,1
K0097.04061	stainless steel	6,6	M6	M15x1	25	20	24	5	4	2	27,1
K0097.05061	stainless steel	6,6	M6	M20x1	32	24	29	6	4	2	43,4
K0097.05081	stainless steel	9	M8	M20x1	32	24	29	6	4	2	43,4
K0097.05101	stainless steel	11	M10	M20x1	32	24	29	6	4	2	43,4
K0097.07101	stainless steel	11	M10	M30x1,5	45	29	36	7	5	2	84
K0097.07121	stainless steel	13,5	M12	M30x1,5	45	29	36	7	5	2	84
K0097.07161	stainless steel	17,5	M16	M30x1,5	45	29	36	7	5	2	84
K0097.09161	stainless steel	17,5	M16	M40x1,5	58	37	46	9	6	2,5	148
K0097.09201	stainless steel	22	M20	M40x1,5	58	37	46	9	6	2,5	148
K0097.09241	stainless steel	26	M24	M40x1,5	58	37	46	9	6	2,5	148
K0097.10201	stainless steel	22	M20	M50x1,5	70	44	54	11	6	2,5	225
K0097.10241	stainless steel	26	M24	M50x1,5	70	44	54	11	6	2,5	225
K0097.10301	stainless steel	33	M30	M50x1,5	70	44	54	11	6	2,5	225



## Levelling sets

spherical washer with locknut

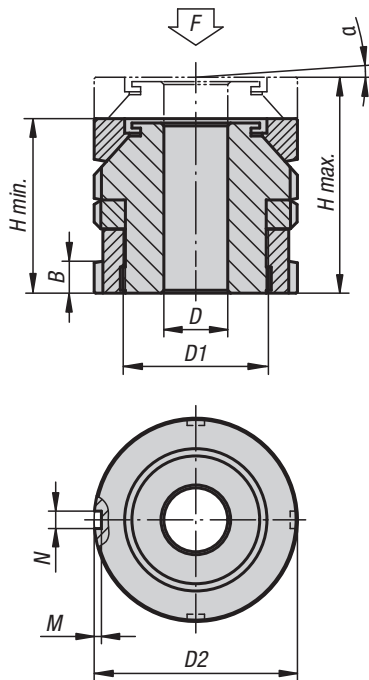

**Material:**

Steel 1.7225.

Stainless steel 1.4305.

**Version:**

Standard version galvanized, blue chromed.

Stainless steel version bright.

**Sample order:**

K0115.0406

**Note:**

The spherical washer levelling set is used to mount and align motors, aggregates, drive units and production lines. The spherical washer gives exact alignment of sloping faces with an inclination of up to 4°. The locknut secures a prescribed adjustment.

**Accessories:**

Spherical levelling washers K0691

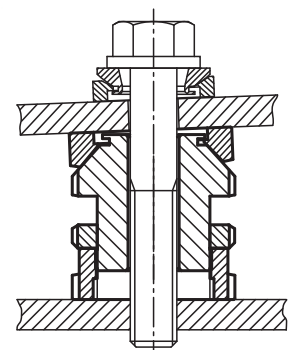

# Levelling sets

spherical washer with locknut

## KIPP Levelling sets spherical washer with locknut

Order No.	Material	D	for screw	D1	D2	H min.	H max.	B	N	M	α	F kN
K0115.0406	steel	6,6	M6	M15x1	25	27	31	5	4	2	4°	40
K0115.0506	steel	6,6	M6	M20x1	32	32	37	6	4	2	4°	65
K0115.0508	steel	9	M8	M20x1	32	32	37	6	4	2	4°	65
K0115.0510	steel	11	M10	M20x1	32	32	37	6	4	2	4°	65
K0115.0710	steel	11	M10	M30x1,5	45	41	48	7	5	2	4°	120
K0115.0712	steel	13,5	M12	M30x1,5	45	41	48	7	5	2	4°	120
K0115.0716	steel	17,5	M16	M30x1,5	45	41	48	7	5	2	4°	120
K0115.0916	steel	17,5	M16	M40x1,5	58	53	62	9	6	2,5	4°	210
K0115.0920	steel	22	M20	M40x1,5	58	53	62	9	6	2,5	4°	210
K0115.0924	steel	26	M24	M40x1,5	58	53	62	9	6	2,5	4°	210
K0115.1020	steel	22	M20	M50x1,5	70	61	71	11	6	2,5	4°	330
K0115.1024	steel	26	M24	M50x1,5	70	61	71	11	6	2,5	4°	330
K0115.1030	steel	33	M30	M50x1,5	70	61	71	11	6	2,5	4°	330
K0115.1224	steel	26	M24	M60x2	80	67	79	11	7	3	4°	495
K0115.1230	steel	33	M30	M60x2	80	67	79	11	7	3	4°	495
K0115.04061	stainless steel	6,6	M6	M15x1	25	27	31	5	4	2	4°	27,1
K0115.05061	stainless steel	6,6	M6	M20x1	32	32	37	6	4	2	4°	43,4
K0115.05081	stainless steel	9	M8	M20x1	32	32	37	6	4	2	4°	43,4
K0115.05101	stainless steel	11	M10	M20x1	32	32	37	6	4	2	4°	43,4
K0115.07101	stainless steel	11	M10	M30x1,5	45	41	48	7	5	2	4°	84
K0115.07121	stainless steel	13,5	M12	M30x1,5	45	41	48	7	5	2	4°	84
K0115.07161	stainless steel	17,5	M16	M30x1,5	45	41	48	7	5	2	4°	84
K0115.09161	stainless steel	17,5	M16	M40x1,5	58	53	62	9	6	2,5	4°	148
K0115.09201	stainless steel	22	M20	M40x1,5	58	53	62	9	6	2,5	4°	148
K0115.09241	stainless steel	26	M24	M40x1,5	58	53	62	9	6	2,5	4°	148
K0115.10201	stainless steel	22	M20	M50x1,5	70	61	71	11	6	2,5	4°	225
K0115.10241	stainless steel	26	M24	M50x1,5	70	61	71	11	6	2,5	4°	225
K0115.10301	stainless steel	33	M30	M50x1,5	70	61	71	11	6	2,5	4°	225
K0115.12241	stainless steel	26	M24	M60x2	80	67	79	11	7	3	4°	323
K0115.12301	stainless steel	33	M30	M60x2	80	67	79	11	7	3	4°	323



# Levelling sets

spherical washer



**Material:**

Steel 1.7225.  
Stainless steel 1.4305.

**Version:**

Standard version galvanized, blue chromed.  
Stainless steel version bright.

**Sample order:**

K0057.1506

**Note:**

The spherical washer levelling sets are used to mount and align motors, aggregates, drive units and production lines. The spherical washer permits exact alignment when mounting sloping surfaces of up to 4°. These levellers have a long travel of 15 mm to 50 mm.

**Accessories:**

Spherical levelling washers K0691

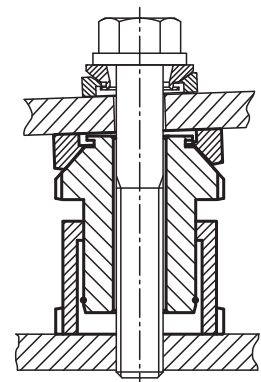
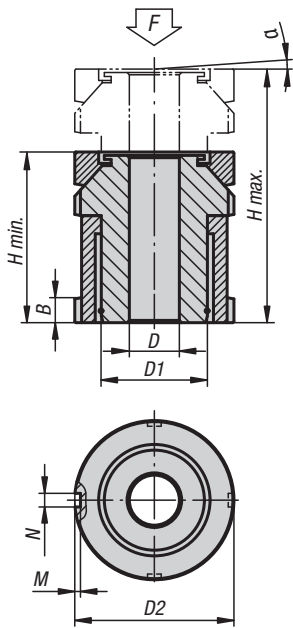



# Levelling sets

spherical washer



## KIPP Levelling sets spherical washer

Order No.	Material	D	for screw	D1	D2	H min.	H max.	B	N	M	α	F kN
K0057.1506	steel	6,6	M6	M15x1	25	35	50	5	4	2	4°	40
K0057.2006	steel	6,6	M6	M20x1	32	43	63	6	4	2	4°	65
K0057.2008	steel	9	M8	M20x1	32	43	63	6	4	2	4°	65
K0057.2010	steel	11	M10	M20x1	32	43	63	6	4	2	4°	65
K0057.2510	steel	11	M10	M30x1,5	45	54	79	7	5	2	4°	120
K0057.2512	steel	13,5	M12	M30x1,5	45	54	79	7	5	2	4°	120
K0057.2516	steel	17,5	M16	M30x1,5	45	54	79	7	5	2	4°	120
K0057.3216	steel	17,5	M16	M40x1,5	58	70	102	9	6	2,5	4°	210
K0057.3220	steel	22	M20	M40x1,5	58	70	102	9	6	2,5	4°	210
K0057.3224	steel	26	M24	M40x1,5	58	70	102	9	6	2,5	4°	210
K0057.4020	steel	22	M20	M50x1,5	70	83	123	11	6	2,5	4°	330
K0057.4024	steel	26	M24	M50x1,5	70	83	123	11	6	2,5	4°	330
K0057.4030	steel	33	M30	M50x1,5	70	83	123	11	6	2,5	4°	330
K0057.5024	steel	26	M24	M60x2	80	94	144	11	7	3	4°	495
K0057.5030	steel	33	M30	M60x2	80	94	144	11	7	3	4°	495
K0057.15061	stainless steel	6,6	M6	M15x1	25	35	50	5	4	2	4°	27,1
K0057.20061	stainless steel	6,6	M6	M20x1	32	43	63	6	4	2	4°	43,4
K0057.20081	stainless steel	9	M8	M20x1	32	43	63	6	4	2	4°	43,4
K0057.20101	stainless steel	11	M10	M20x1	32	43	63	6	4	2	4°	43,4
K0057.25101	stainless steel	11	M10	M30x1,5	45	54	79	7	5	2	4°	84
K0057.25121	stainless steel	13,5	M12	M30x1,5	45	54	79	7	5	2	4°	84
K0057.25161	stainless steel	17,5	M16	M30x1,5	45	54	79	7	5	2	4°	84
K0057.32161	stainless steel	17,5	M16	M40x1,5	58	70	102	9	6	2,5	4°	148
K0057.32201	stainless steel	22	M20	M40x1,5	58	70	102	9	6	2,5	4°	148
K0057.32241	stainless steel	26	M24	M40x1,5	58	70	102	9	6	2,5	4°	148
K0057.40201	stainless steel	22	M20	M50x1,5	70	83	123	11	6	2,5	4°	225
K0057.40241	stainless steel	26	M24	M50x1,5	70	83	123	11	6	2,5	4°	225
K0057.40301	stainless steel	33	M30	M50x1,5	70	83	123	11	6	2,5	4°	225
K0057.50241	stainless steel	26	M24	M60x2	80	94	144	11	7	3	4°	323
K0057.50301	stainless steel	33	M30	M60x2	80	94	144	11	7	3	4°	323



# Levelling sets

spherical washer with locknut



**Material:**

Steel 1.7225.

Stainless steel 1.4305.

**Version:**

Standard version galvanized, blue chromed.

Stainless steel version bright.

**Sample order:**

K0119.1006

**Note:**

The spherical washer levelling sets are used to mount and align motors, aggregates, drive units and production lines. The spherical washer permits exact alignment when mounting sloping surfaces of up to 4°. The locknut secures a prescribed adjustment. These levellers have a long travel of 10 mm to 39 mm.

**Accessories:**

Spherical levelling washers K0691

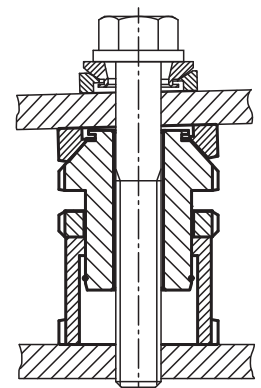
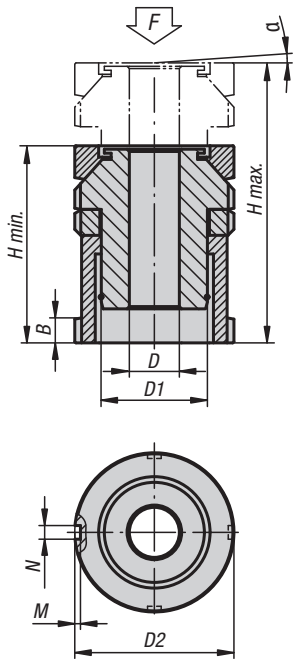

# Levelling sets

spherical washer with locknut

## KIPP Levelling sets spherical washer with locknut

Order No.	Material	D	for screw	D1	D2	H min.	H max.	B	N	M	$\alpha$	F kN
K0119.1006	steel	6,6	M6	M15x1	25	40	50	5	4	2	4°	40
K0119.1406	steel	6,6	M6	M20x1	32	49	63	6	4	2	4°	65
K0119.1408	steel	9	M8	M20x1	32	49	63	6	4	2	4°	65
K0119.1410	steel	11	M10	M20x1	32	49	63	6	4	2	4°	65
K0119.1810	steel	11	M10	M30x1,5	45	61	79	7	5	2	4°	120
K0119.1812	steel	13,5	M12	M30x1,5	45	61	79	7	5	2	4°	120
K0119.1816	steel	17,5	M16	M30x1,5	45	61	79	7	5	2	4°	120
K0119.2316	steel	17,5	M16	M40x1,5	58	79	102	9	6	2,5	4°	210
K0119.2320	steel	22	M20	M40x1,5	58	79	102	9	6	2,5	4°	210
K0119.2324	steel	26	M24	M40x1,5	58	79	102	9	6	2,5	4°	210
K0119.2920	steel	22	M20	M50x1,5	70	94	123	11	6	2,5	4°	330
K0119.2924	steel	26	M24	M50x1,5	70	94	123	11	6	2,5	4°	330
K0119.2930	steel	33	M30	M50x1,5	70	94	123	11	6	2,5	4°	330
K0119.3924	steel	26	M24	M60x2	80	105	144	11	7	3	4°	495
K0119.3930	steel	33	M30	M60x2	80	105	144	11	7	3	4°	495
K0119.10061	stainless steel	6,6	M6	M15x1	25	40	50	5	4	2	4°	27,1
K0119.14061	stainless steel	6,6	M6	M20x1	32	49	63	6	4	2	4°	43,4
K0119.14081	stainless steel	9	M8	M20x1	32	49	63	6	4	2	4°	43,4
K0119.14101	stainless steel	11	M10	M20x1	32	49	63	6	4	2	4°	43,4
K0119.18101	stainless steel	11	M10	M30x1,5	45	61	79	7	5	2	4°	84
K0119.18121	stainless steel	13,5	M12	M30x1,5	45	61	79	7	5	2	4°	84
K0119.18161	stainless steel	17,5	M16	M30x1,5	45	61	79	7	5	2	4°	84
K0119.23161	stainless steel	17,5	M16	M40x1,5	58	79	102	9	6	2,5	4°	148
K0119.23201	stainless steel	22	M20	M40x1,5	58	79	102	9	6	2,5	4°	148
K0119.23241	stainless steel	26	M24	M40x1,5	58	79	102	9	6	2,5	4°	148
K0119.29201	stainless steel	22	M20	M50x1,5	70	94	123	11	6	2,5	4°	225
K0119.29241	stainless steel	26	M24	M50x1,5	70	94	123	11	6	2,5	4°	225
K0119.29301	stainless steel	33	M30	M50x1,5	70	94	123	11	6	2,5	4°	225
K0119.39241	stainless steel	26	M24	M60x2	80	105	144	11	7	3	4°	323
K0119.39301	stainless steel	33	M30	M60x2	80	105	144	11	7	3	4°	323



